

**Rocky Mountains Cooperative Ecosystem Studies Unit (RM-CESU)**  
**RM-CESU Cooperative Agreement Number: H1200040001**

Yellowstone Winter Use Personal Exposure Monitoring

Final Report

Prepared For:

National Park Service

Report Date:

June 1, 2005

Prepared By:

Terry M. Spear, Montana Tech of The University of Montana  
Dale J. Stephenson, Boise State University

## Table of Contents

<b>I.</b>	<b>Executive Summary</b>	<b>4</b>
<b>II.</b>	<b>Introduction</b>	<b>5</b>
<b>III.</b>	<b>Materials and Methods</b>	<b>6</b>
	<b>A. Snowmobile Entries</b>	<b>7</b>
	<b>B. Aldehydes</b>	<b>7</b>
	<b>C. BETX and Total Petroleum Hydrocarbons</b>	<b>8</b>
	<b>D. Volatile organic compounds (VOCs)</b>	<b>8</b>
	<b>E. Elemental and Organic Carbon</b>	<b>8</b>
	<b>F. Oxides of Nitrogen</b>	<b>9</b>
	<b>G. Carbon Monoxide</b>	<b>9</b>
	<b>H. Respirable particulate matter</b>	<b>9</b>
	<b>I. Noise</b>	<b>10</b>
<b>IV.</b>	<b>Results and Discussion</b>	<b>11</b>
	<b>A. Snowmobile and Snow Coach Entries</b>	<b>11</b>
	<b>B. Aldehyde Results</b>	<b>12</b>
	<b>C. BETX and Total Petroleum Hydrocarbon Results</b>	<b>12</b>
	<b>D. Volatile organic compound (VOC) Results</b>	<b>12</b>
	<b>E. Elemental and Organic Carbon Results</b>	<b>17</b>
	<b>F. Oxides of Nitrogen Results</b>	<b>17</b>
	<b>G. Carbon Monoxide Results</b>	<b>18</b>
	<b>H. Respirable particulate matter Results</b>	<b>18</b>
	<b>1. Particle Count Data</b>	<b>19</b>
	<b>2. Particle Mass Concentration Data</b>	<b>20</b>
	<b>I. Noise Results</b>	<b>25</b>
<b>V.</b>	<b>Comparison of the Current Study with Previous Air Quality Studies</b>	<b>26</b>
	<b>A. Previous Air Quality Studies</b>	<b>26</b>
	<b>B. Findings of Current Study</b>	<b>27</b>
<b>VI.</b>	<b>Risk Assessment</b>	<b>29</b>
	<b>A. Occupational Exposure</b>	<b>29</b>
	<b>B. Public Exposure</b>	<b>31</b>
<b>VII.</b>	<b>Conclusions and recommendations</b>	<b>32</b>
	<b>References</b>	<b>34</b>
	<b>Appendix A</b> Description of these established exposure limits	<b>36</b>
	<b>Appendix B</b> Analytical methods	<b>41</b>
	<b>Appendix C</b> Integrated sampling results	<b>135</b>
	<b>Appendix D</b> Data Chem Laboratories integrated analytical reports	<b>152</b>
	<b>Appendix E</b> Data Chem Laboratories analytical reports for VOCs	<b>208</b>
	<b>Appendix F</b> Maps	<b>253</b>

## List of Figures

<b>Figure 1</b>	Snowmobile and Snow Coach Entries on 2/19/05	11
<b>Figure 2</b>	Graph of particle counts with time in kiosk A at the West Entrance	19
<b>Figure 3</b>	Graph of particle counts with time in the Madison Warming Hut	20
<b>Figure 4</b>	Real time PM <sub>2.5</sub> particle concentrations – West Entrance Kiosk A (1/15/05)	21
<b>Figure 5</b>	Real time PM <sub>10</sub> particle concentrations – West Entrance Kiosk A (1/16/05)	22
<b>Figure 6</b>	Real time PM <sub>2.5</sub> particle concentrations – Madison Warming Hut (1/17/05)	22
<b>Figure 7</b>	Real time PM <sub>2.5</sub> particle concentrations – West Entrance Kiosk A (2/19/05)	23
<b>Figure 8</b>	Real time PM <sub>2.5</sub> particle concentrations – West Entrance Kiosk A (2/20/05)	23
<b>Figure 9</b>	Real time PM <sub>2.5</sub> particle concentrations – West Entrance Kiosk A (2/21/05)	24
<b>Figure 10</b>	Real time PM <sub>2.5</sub> particle concentrations – Mammoth Mech. Shop (2/07/05)	24

## List of Tables

<b>Table 1.</b>	Snowmobile Emission Factors	5
<b>Table 2.</b>	Summary of 4-Stroke Snowmobile Emission Engine Emission Factors of 2002	6
<b>Table 3.</b>	Number of West Entrance Entries by Date	11
<b>Table 4.</b>	Volatile Organic Compounds Identified by Method TO-15	14, 15
<b>Table 5.</b>	ATSDR Minimal Risk Levels (MRLs) December 2004	16, 17
<b>Table 6.</b>	Real Time Nitrogen Dioxide Concentrations	18
<b>Table 7.</b>	Real Time Carbon Monoxide Concentrations	18
<b>Table 8.</b>	P-Trak particle count data in the West Entrance Kiosk A	19
<b>Table 9.</b>	P-Trak particle count data in the Madison Warming Hut	20
<b>Table 10.</b>	Real time particle mass concentration data	21
<b>Table 11.</b>	Personal Noise Dosimetry Results	25
 <b>Appendix C</b>		
<b>Table 1A.</b>	Aldehydes	136
<b>Table 1B.</b>	BETX and Total Petroleum Hydrocarbons	138
<b>Table 1C.</b>	Elemental and Organic Carbon	141
<b>Table 1D.</b>	Oxides of Nitrogen	146
<b>Table 1E.</b>	Respirable Particulate	149

## **I. Executive Summary**

In January 2005, the National Park Service contracted with Montana Tech of The University of Montana and Boise State University to evaluate employee exposure to air contaminants and noise associated with snowmobile operations in Yellowstone National Park. The exposure evaluations were performed at the Park's West Entrance and Madison Warming Hut during the 2005 Martin Luther King three-day weekend (January 15<sup>th</sup>, 16<sup>th</sup>, and 17<sup>th</sup>) and the 2005 President's Day three-day weekend (February 19<sup>th</sup>, 20<sup>th</sup>, and 21<sup>st</sup>). Employee exposure evaluations were also performed at the Mammoth Hot Springs Maintenance shop on February 7, 2005.

The employee exposure evaluations were performed during anticipated peak levels of snowmobile use in an attempt to obtain worst-case measurements during winter use work activities. Due to the absence of inversions noted during the monitoring dates of the current study, worst-case data were not collected. Personal and area air sampling and noise monitoring were performed on Yellowstone National Park's West Entrance personnel, warming hut personnel, snowmobile mechanics, and park rangers. Personal and area air samples were collected for the following contaminants:

- Aldehyde screen
- BETX (benzene, ethyl benzene, toluene, and xylenes)
- Total hydrocarbons
- Volatile organic compounds (VOCs)
- Elemental and organic carbon
- Oxides of Nitrogen
- Carbon Monoxide
- Respirable particulate matter (2.5 µm and 4.0 µm)

The results of the current study were compared to established occupational exposure limits [Permissible Exposure Limits (PELs), Threshold Limit Values (TLVs), National Institute of Occupational Health Recommended Exposure Limits (NIOSH RELs)] for all of the contaminants listed above, with the exception of VOCs. VOC results were compared to established recommended exposure limits [(Minimal Risk Levels (MRL))]. All employee exposure to the above air contaminants and noise were well below established Occupational Safety and Health Administration (OSHA) Permissible Exposure Limits (PELs) and other established recommended exposure limits.

The results from the current study were also compared with previous studies to evaluate trends in occupational exposure to Park Service personnel. Comparison of the current study with previous studies shows a general decrease in exposure to aldehydes, BETX, VOCs, and respirable particulate matter. The results of noise exposure received by Park Service Personnel were similar to those found in previous studies with the only area of

noise concern being the riders of snowmobiles whose 8-hour TWAs exceeded the OSHA Hearing Conservation Amendment and approached the OSHA Engineering Standard.

## II. Introduction

In November 2004, The National Park Service published its final rule allowing up to 720 snowmobiles per day to enter Yellowstone National Park. The total daily commercially guided snowmobile entry limits are 400, 220, 40, 30 and 30 for the West Entrance, South Entrance, East Entrance, North Entrance, and Old Faithful, respectively. The final rule also allows only those snowmobiles that meet the National Park Service Best Available Technology requirements.<sup>1</sup>

Vehicle exhaust from snowmobiles contains numerous toxic compounds. Four-stroke engines emit substantially less hydrocarbons (HC), particulate matter (PM), and carbon monoxide, but more nitrogen oxides (NO<sub>x</sub>) than 2-stroke engines.<sup>2</sup> A comparison of 2-stroke vs. 4-stroke engine exhaust emissions is shown in Table 1.

**Table 1. Snowmobile Emission Factors**

<i>Source of Emission Factor</i>	<i>Emission Factor, grams/hp-hr</i>			
	<b>HC</b>	<b>NO<sub>x</sub></b>	<b>CO</b>	<b>PM</b>
<i>2-stroke engines</i>				
1. SwRI 98 Polaris Base	151	0.4	416	1.3
2. SwRI 98 Polaris Rich	180	0.3	474	1.7
3. SwRI 98 Polaris Gasohol	127	0.4	377	1.0
4. SwRI 98 Polaris Gasohol/Bio Lube	104	0.4	332	1.7
5. SwRI 98 Polaris Aliphatic	201	0.5	424	2.0
6. SwRI 98 Arctic Cat Gasoline	156	0.5	363	3.5
7. SwRI 98 Arctic Cat Gasohol	164	0.5	342	3.4
8. SwRI 99 Polaris BASE	116	0.7	376	0.7
9. SwRI 99 Polaris BIO	120	0.7	391	1.4
<i>4-stroke engines</i>				
10. EPA 4-stroke overhead engine	5.2	3.5	409	0.04
11. CARB 4-stroke <= 25 hp	4	1.8	240	0.09
12. CARB 4-stroke >25 hp	2	3	150	0.00

1-7. *Emissions from Snowmobile Engines using Bio-based Fuels and Lubricants*, White and Carroll, 1998

8-9. *“Characterization of Snowmobile Particulate Emissions,”* Carroll and White, 1999

10. Exhaust Emission Factors for Nonroad Engine Modeling—Spark Ignition, U.S. EPA Report No. NR-010b (EPA420-R-99-009), 1999

11-12. Emission Factors files (\*.emf) used for Nonroad model at: <http://www.epa.gov/oms/nonrdmdl.htm>

Additional data on 4-stroke “best available technology” BAT snowmobile engine emissions are presented in Table 2

**Table 2. Summary of 4-Stroke Snowmobile Emission Engine Emission Factors of 2002**

<i>Snowmobile Engine</i>	<i>Emission, grams/hp-hr</i>				
	<b>HC</b>	<b>NOx</b>	<b>CO</b>	<b>PM</b>	<b>Brake Specific Fuel Consumption</b>
Arctic Cat 4-Stroke, mean	4.62	7.93	59.6	0.065	0.602
Polaris 4-stroke, mean	2.38	5.20	59.0	0.085	0.694
4-stroke, mean	3.5	6.57	59.3	0.075	0.648

*Lela, Chad; White, Jeff J; Haines, Howard; and Sacklin, John. July 2002. Laboratory Testing of Snowmobile Emissions: Southwest Research Institute, Report number SwRI 08.05486, Table 9, Two-Stroke VS. 4-Stroke, Snowmobile Engine Emissions, and Fuel Consumption Comparison.*

In addition to the snowmobile emission data presented in Tables 1 and 2, there are BAT requirements for snowmobile sound emissions. These BAT requirements are 73 dBA or less at idling speed. The Society of Automotive Engineers testing procedures allow for a 2 dB tolerance over the sound level limit to provide for variations in test site, temperature gradients, wind velocity gradients, test equipment, and inherent differences in nominally identical vehicles. It has been observed that under some test site conditions, variability in test results greater than 2 dB can be experienced.

During the months of January and February, 2005, an industrial hygiene survey was performed in Yellowstone National Park. The major objective of the survey was to evaluate Park Service personnel exposure to particulate matter, air contaminants, and noise emitted by snowmobiles. Personal and area air sampling and noise monitoring were performed on west entrance personnel, warming hut personnel, snowmobile mechanics, and park rangers over the course of 8 working days. The employee exposure evaluations were performed during anticipated peak levels of snowmobile use in an attempt to obtain worst-case measurements during winter use work activities. Samples were collected during the Martin Luther King three-day weekend (January 15<sup>th</sup>, 16<sup>th</sup>, and 17<sup>th</sup>, 2005), on February 7<sup>th</sup>, 2005, and the President’s Day three-day weekend (February 19<sup>th</sup>, 20<sup>th</sup>, and 21<sup>st</sup>, 2005).

The results of the current study are summarized in this report. The current results are also compared to previous studies<sup>3,4,5,6</sup> to evaluate trends in occupational exposure to Park Service personnel.

### **III. Material and Methods**

Personal and area air samples were collected to determine Park Service employee exposure to noise and specific toxic air contaminants. The area air samples were located at workstations so that estimates of employee exposure could be determined. Personal samples were collected on employees wearing sample media. Personal and area air samples were collected for the following contaminants:

- Aldehyde screen
- BETX (benzene, ethyl benzene, toluene, and xylenes)
- Total petroleum hydrocarbons
- Volatile organic compounds (VOCs)
- Elemental and organic carbon
- Oxides of Nitrogen
- Carbon Monoxide
- Respirable particulate matter 2.5, 4.0, and 10 micrometer ( $\mu\text{m}$ ) aerodynamic diameter

The bulk of the employee exposure monitoring was conducted at the West Entrance kiosks because the majority of the snowmobiles enter the Park by this route. Sampling was also performed at the Madison Warming Hut, at the Mammoth Maintenance Shop, and on Park rangers operating snowmobiles. At the Park's West Entrance all samples were collected on a partial shift basis due to fact that Park employees only monitor snowmobiles as they enter the Park and all entries were typically completed by approximately noon each day. Similarly, samples collected at the Madison Warming Hut and the Mammoth Hot Springs Mechanic Shop were also partial shift, due either to the limited availability of an employee to be monitored or the time that a Park employee spends in a potentially contaminated area. In all cases, the sample results were integrated over an 8-hour time period to allow for appropriate comparison with established occupational exposure limits. VOCs were compared to Minimal Risk Levels established by the Agency for Toxic Substance and Disease Registry. See Appendix A for a description of these established exposure limits.

#### A. Snowmobile Entries

In an effort to correlate the level of air and noise emissions with the number of winter recreational vehicles entering through the Park's West Entrance, the number and type of snowmobiles and snow coaches were logged each sampling day by National Park Service staff. As the bulk of air contaminant and noise exposure is associated with Park employees monitoring traffic as it passes a kiosk, only vehicles entering the park were logged.

#### B. Aldehydes

Aldehyde samples were collected according to National Institute for Occupational Safety and Health (NIOSH) Manual of Analytical Methods (NMAM) 2539. The sampling media consisted of a solid sorbent tube (10% 2-hydroxymethyl piperidine on XAD-2, 120 mg/60 mg). The samples were collected at a flow rate of 0.01 to 0.05 L/min using SKC



low flow sampling pumps. Sampling pumps were calibrated using a Gilian<sup>®</sup> Gilibrator<sup>™</sup> before and after each sampling day. Samples were analyzed by Data Chem Laboratories, an American Industrial Hygiene Association (AIHA) accredited laboratory. Samples were analyzed by gas chromatography/mass spectrometry (GC/MS) for the following compounds: acetaldehyde; acrolein, butyraldehyde, formaldehyde, heptanal, hexanal, isovaleraldehyde, propionaldehyde, and valeraldehyde. The estimated limit of detection (LOD) for this method is 2 µg of aldehyde per sample. Three blank samples were submitted for analysis for quality control assurance. (NIOSH NMAM 2539 can be viewed in Appendix B).

#### C. BETX and Total Petroleum Hydrocarbons

BETX ((benzene, ethyl benzene, toluene, and xylenes) and total petroleum hydrocarbon samples were collected according to NIOSH NMAM 1501. The sampling media consisted of a solid sorbent tube (coconut shell charcoal, 100 mg/50 mg). The samples were collected at a flow rate of 0.02 L/min using SKC low flow sampling pumps. Sampling pumps were calibrated using a Gilian<sup>®</sup> Gilibrator<sup>™</sup> before and after each sampling day. Samples were analyzed by Data Chem Laboratories using GC for the following compounds: benzene (LOD 0.5 µg/sample), toluene (LOD 0.7 µg/sample), ethyl benzene (LOD 0.5 µg/sample), xylene (LOD 0.8 µg/sample), and total hydrocarbons (LOD 0.6 µg/sample). Three blank samples were submitted for analysis for quality control assurance. (NIOSH NMAM 1501 can be viewed in Appendix B).

#### D. Volatile organic compounds (VOCs)

VOC samples were collected according to Environmental Protection Agency (EPA) analytical method TO-15 (Method TO-15 can be viewed in Appendix B). This method documents sampling and analytical procedures for the measurement of subsets of the 97 volatile organic compounds (VOCs) that are included in the 189 hazardous air pollutants (HAPs) listed in Title III of the Clean Air Act Amendments of 1990. VOCs are defined here as organic compounds having a vapor pressure greater than 10 Torr at 25°C and 760 mm Hg. The sampling media consisted of 400-ml stainless steel mini-canisters used with a sampling regulator to allow for an extended sampling time. The method was used for the determination of volatile organic compounds (VOCs) in air. Samples were analyzed by Data Chem Laboratories through analysis by GC/MS.

#### E. Elemental and Organic Carbon

Elemental and organic carbon samples were collected according to NIOSH NMAM 5040. The sampling media consisted of a 37-mm quartz fiber filters housed in SKC aluminum cyclones with a cut point of 4.0 µm. The samples were collected at a flow rate of 2.5 L/min using Mines Safety Appliances<sup>®</sup> (MSA) Escort Elf<sup>™</sup> personal sampling pumps. Sampling pumps were calibrated using a Gilian<sup>®</sup> Gilibrator<sup>™</sup> before and after each sampling day. Samples were analyzed by Data Chem Laboratories using evolved gas analysis (EGA) by thermal-optical analyzer. The estimated limit of detection (LOD) for

this method is 1.0 µg per filter portion. Three blank samples were submitted for analysis for quality control assurance. (NIOSH NMAM 5040 can be viewed in Appendix B).

#### F. Oxides of Nitrogen

Samples for oxide of nitrogen were collected using both integrated and direct reading instrumentation. Integrated samples were collected according to NIOSH NMAM 6041. The sampling media consisted of a solid sorbent tube (oxidizer + 2 triethanolamine-treated molecular sieves). The samples were collected at a flow rate of 0.025 L/min using SKC low flow sampling pumps. Sampling pumps were calibrated using a Gilian<sup>®</sup> Gilibrator<sup>™</sup> before and after each sampling day. Samples were analyzed by Data Chem Laboratories using visible absorption spectrophotometry for nitric oxide (NO) and nitrogen dioxide (NO<sub>2</sub>). The estimated limit of detection (LOD) for this method is 1.0 µg NO<sub>2</sub> per sample. Six blank samples were submitted for analysis for quality control assurance. (NIOSH NMAM 6041 can be viewed in Appendix B)

NO<sub>2</sub> was also measured using an Industrial Scientific iTX<sup>®</sup> Multi-Gas Monitor<sup>™</sup>. The instrument was equipped with an electrochemical sensor that measures nitrogen dioxide ranging from 0.2 ppm to 99.9 ppm, in 0.1 ppm increments. The Multi-Gas Monitor was setup to data log every 10 seconds while monitoring. Montana Tech received the Multi-Gas monitor from the manufacturer within 1 month of its use in our research, making the instrument in compliance with the manufacturer's recommendations. In addition, the Multi-Gas Monitor was "bump" tested in accordance with Industrial Scientific's recommendations. The data recorded during our research was downloaded and analyzed using Industrial Scientific's software. The instrument was zeroed and calibrated with a certified NO<sub>2</sub> span gas each day prior to use.

#### G. Carbon Monoxide

Carbon monoxide was measured using an Industrial Scientific iTX<sup>®</sup> Multi-Gas Monitor<sup>™</sup>. The Multi-Gas Monitor was equipped with an electrochemical sensor that measures carbon monoxide ranging from 0 to 999 ppm, in 1 ppm increments. The Multi-Gas Monitor was setup to log data every 10 seconds during the monitoring period. Montana Tech received the Multi-Gas monitor from the manufacturer within 1 month of its use in our research, making the instrument in compliance with the manufacturer's recommendations. In addition, the Multi-Gas Monitor was "bump" tested in accordance with Industrial Scientific's recommendations. The data recorded during our research was downloaded and analyzed using Industrial Scientific's software. The instrument was zeroed and calibrated with a certified CO span gas each day prior to use.

#### H. Respirable particulate matter

Samples for respirable particulate matter (2.5, 4.0, and 10 micrometer (µm) aerodynamic diameter) were collected using both integrated and real time aerosol samplers. Integrated samples were collected according to NIOSH NMAM 0500. The sampling media consisted of a 37-mm polytetrafluoroethylene (PTFE) filter with a 0.45 µm pore size

housed in SKC aluminum cyclones with a cut point of 4.0  $\mu\text{m}$ . The samples were collected at a flow rate of 2.5 L/min using MSA Escort Elf personal sampling pumps. Sampling pumps were calibrated using a Gilian<sup>®</sup> Gilibrator<sup>™</sup> before and after each sampling shift. Samples were analyzed by Data Chem Laboratories using gravimetric analysis. The estimated limit of detection (LOD) for this method is 0.03 mg per sample. Three blank samples were submitted for analysis for quality control assurance. (NIOSH NMAM 0500 can be viewed in Appendix B).

Real time respirable particulate samples were collected with the following direct reading instrumentation:

#### Thermo-Electron<sup>®</sup> (MIE) DataRAM<sup>™</sup>

The DataRAM is a light-scattering photometer (i.e., nephelometer) that incorporates a pulsed, high output, near-infrared light emitting diode source, a silicon detector / hybrid preamplifier, collimating optics, and a source reference feedback PIN silicon detector. The intensity of the light scattered over the forward angle of 45° to 90° by the airborne particles passing through the sensing chamber is linearly proportional to their concentration. The DataRAM's optical configuration produces optimal volume response to particles in the size range of 0.1 to 10 $\mu\text{m}$ , achieving high correlation with standard gravimetric measurements of the respirable and thoracic fractions. The DataRAM was configured using a sampling head that selectively measures particulate mass at a 50% cut point of 2.5  $\mu\text{m}$  (PM<sub>2.5</sub>).

#### TSI<sup>®</sup> P-trak<sup>™</sup> ultra-fine particle counter

The TSI<sup>®</sup> P-trak<sup>™</sup> measures particle number concentrations in the 0.02 to 1  $\mu\text{m}$  particle size range. Suspended particles are drawn through the machine by a built-in pump. Upon entering the instrument, particles pass through a saturator tube where they mix with alcohol vapor. The particle/alcohol mixture is drawn into a condenser tube where alcohol condenses on the particles causing them to grow into droplets, facilitating particle counting. The droplets then pass through a focused laser beam, producing flashes of light. The light flashes are sensed by a photodetector and counted to determine particle number counts.

### I. Noise

Quest Q400 type 2 personal dosimeters were used to evaluate noise exposure to Park Service personnel as they monitored snowmobiles and snow coaches entering the West Entrance to Yellowstone National Park. The internal settings of each dosimeter matched the OSHA criteria for evaluating noise exposure (i.e. a threshold of 80 dB and 90 dB, a criterion level of 90 dB, an exchange rate of 5 dB, and a slow time constant). For all sampling events, pre- and post-calibrations were performed on each dosimeter using a Quest Model CA-12B acoustical calibrator. All calibrations were made at a sound pressure level of 114dB at 1000 Hz. All noise samples were taken in the hearing zone of affected personnel and the instruments were configured to not interfere with an employee's normal job activities.

#### IV. Results and Discussion

The integrated monitoring data for aldehydes, BETX and total hydrocarbons, elemental and organic carbon, and oxides of nitrogen (NO and NO<sub>2</sub>), and respirable particulate are presented in Tables 1A-1E respectively in Appendix C. OSHA PELs, American Conference of Governmental Industrial Hygienists Threshold Limit Values (ACGIH-TLVs), and NIOSH Recommended Exposure Limits (RELs) are also shown in the tables for comparison with exposure measurements. See Appendix D for copies of Data Chem Laboratories analytical reports for all integrated sample analysis, with the exception of the VOCs analytical reports. The VOCs analytical reports are shown in Appendix E.

##### A. Snowmobile and Snow Coach Entries

Table 2 below summarizes the number of snowmobiles and snow coaches that entered through the West Entrance to Yellowstone National Park during the 2005 Martin Luther King and Presidents' Day weekends. The entries were logged each day by the Park Service Employees.

**Table 3. Number of West Entrance Entries by Date**

Date	# Snowmobiles	# Snow Coaches
1/15/05	163	21
1/16/05	142	12
1/17/05	109	19
2/19/05	279	25
2/20/05	227	23
2/21/05	164	15

In an effort to characterize the time frame of entry for snowmobiles and snow coaches passing the West Entrance kiosks, Figure 1 below provides a time series describing the number of vehicles entering the Park on February 19<sup>th</sup>, 2005. As can be seen in Figure 1, early to midmorning is the dominant period for entries to be made through the West Entrance, with little to no traffic in the afternoon. This traffic pattern was consistent throughout the duration of this project.

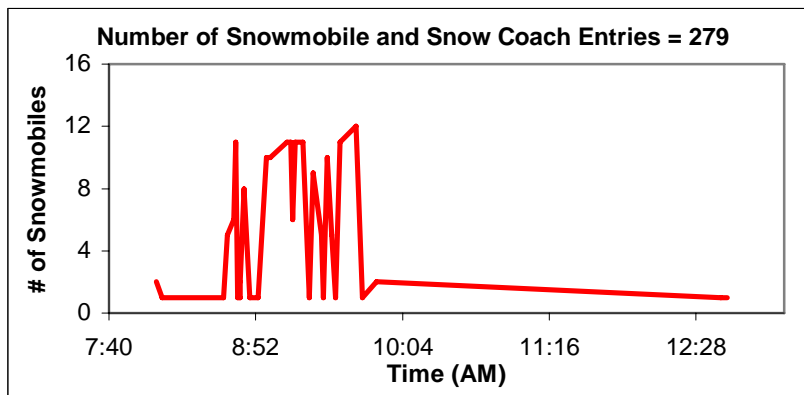

**Figure 1. Snowmobile and Snow Coach Entries on 2/19/05**

## B. Aldehyde Results

A total of six samples for employee exposure to aldehydes were collected for this project. During the Martin Luther King weekend on January 15, 16, and 17, 2005, two samples were collected at the West Entrance kiosks and one sample was collected at the Madison Warming Hut. One aldehyde sample was collected at the Mammoth Maintenance Shop on February 7, 2005, and two samples were collected at the West Entrance kiosks during President's Day weekend on February 19 and 20, 2005. Samples were analyzed by GC/MS for the following compounds: acetaldehyde; acrolein, butyraldehyde, formaldehyde, heptanal, hexanal, iso-valeraldehyde, propionaldehyde, and valeraldehyde. The estimated limit of detection (LOD) for this method is 2 µg of aldehyde per sample. All samples for aldehydes were area samples located at workstations so that estimates of employee exposure could be determined. All samples were reported as less than the LOD for the analytical method and thus were below established occupational exposure limits (see Appendix C Table 1A).

## C. BETX and Total Hydrocarbon Results

A total of ten samples for employee exposure to BETX and total hydrocarbons were collected. Three samples were personal samples and seven samples were area samples located in employee workstations. During the Martin Luther King weekend on January 15, 16, and 17, 2005, three samples were collected at the West Entrance kiosks and one sample was collected at the Madison Warming Hut. One sample was collected at the Mammoth Maintenance Shop on February 7, 2005, and five samples were collected at the West Entrance kiosks during President's Day weekend on February 19, 20, and 21, 2005. Samples were analyzed using GC for benzene, toluene, ethyl benzene, xylene, and total hydrocarbons. All samples were well below established occupational exposure limits, with the exception of area sample 2BWH, collected for toluene on 1/16/2005 in the Madison Warming Hut (see Appendix C Table 1B).

## D. Volatile Organic Compound (VOC) Results

A total of 11 mini-can samples for VOCs were collected. One area sample was collected in kiosk A each day on January 15, 16, and 17, 2005. One personal sample was collected on a Park Ranger on January 16, 2005 while he performed his ranger duties operating a BAT 2003 Polaris Frontier Touring snowmobile. One personal sample was collected on a Mammoth Maintenance Shop worker on February 7, 2005. One area sample was collected in kiosk A each day on February 19, 20, and 21, 2005. One area sample was also collected in the office building at the West Entrance on February 19, 2005. One personal sample was collected on a park ranger at Old Faithful on February 20, 2005, operating a 2004 BAT Arctic Cat T660 Touring. One area sample was also collected at the air intake to the ventilation system for the kiosks at the West Entrance on February 21, 2005.

The results of the mini-can samples for VOCs are shown in Table 3. The results for the various compounds identified in the samples are expressed in part per million (ppm). The results in Table 3 are best interpreted by comparison with sample 222AI. This sample was collected near the air intake to the ventilation system for the kiosks at the West Entrance on February 21, 2005, to serve as a control sample. The only contaminant detected in this sample was acetone at 0.0013 ppm. Overall the total VOC concentration range was low. Samples 116G and 220KA showed the highest concentrations of total petroleum hydrocarbons (0.63 and 0.22 ppm respectively). Both of these samples were area samples located in kiosk A. It is interesting to note that sample 219OB, which was collected in the office building at the West Entrance on February 19, 2005, showed similar constituents as were found in the area kiosk samples. The two samples collected on rangers operating snowmobiles (samples 116SM and 220R) were similar to each other and were not significantly different in compounds or concentrations from samples collected in the kiosks. See Appendix E for copies of Data Chem Laboratories analytical reports for VOCs analysis.

The following describes the sample type and location of the mini-can samples.

- #1 mini-can** -- Area sample in kiosk A at the West Entrance.
- 116 G**----- Area sample in kiosk A at the West Entrance.
- 116 SM** ----- Personal sample worn by a Park Ranger operating 2003 BAT Polaris Frontier Touring snowmobile.
- 117 G**----- Area sample in kiosk A at the West Entrance.
- MC27** ----- Personal sample collected from a mechanic at the Mammoth maintenance shop.
- 219KA** ----- Area sample in kiosk A at the West Entrance.
- 219OB** ----- Area sample collected in the West Entrance office.
- 220KA** ----- Area sample in kiosk A at the West Entrance.
- 220R**----- Personal sample worn by a law enforcement ranger operating a 2004 BAT Arctic Cat T660 Touring snowmobile.
- 220KA** ----- Area sample in kiosk A at the West Entrance.
- 222AI** ----- Area sample collected near the air intake to the kiosk ventilation system

(Refer to figure 1 in Appendix F for sampling locations)

The Agency for Toxic Substances and Disease Registry (ATSDR) Minimal Risk Levels (MRLs) that have been established for compounds listed in Table 3 are shown in Table 4. An MRL is an estimate of the daily human exposure to a hazardous substance that is likely to be without appreciable risk of adverse non-cancer health effects over a specified duration of exposure. These substance specific estimates, which are intended to serve as screening levels, are used by ATSDR health assessors and other responders to identify contaminants and potential health effects that may be of concern at hazardous waste sites. All of the compounds reported above the limit of detection in Table 3 are below all established recommended MRL (acute, intermediate, and chronic) levels in Table 4.

**Table 4. Volatile Organic Compounds Identified by Method TO-15**

*ND – None Detected	1/15/2005	1/16/2005	1/16/2005	1/17/2005	2/7/2005	2/19/2005	2/19/2005	2/20/2005	2/20/2005	2/21/2005	2/21/2005
	#1 mini can	116 G	116 SM	117 G	MC27	219KA	219OB	220KA	220R	222KA	222AI
Analyte	PPM	PPM	PPM	PPM	PPM	PPM	PPM	PPM	PPM	PPM	PPM
Dichlorodifluoromethane	0.00047	0.00052	0.0032	0.0004	0.0016	0.00096	0.00045	0.00055	ND	ND	ND
Chloromethane	0.0028	ND	0.0015	0.0012	0.0015	0.0015	0.00052	0.00071	0.00058	ND	ND
Freon 114	ND	ND	ND	ND	ND	ND	ND	ND	ND	ND	ND
Vinyl Chloride	ND	ND	ND	ND	ND	ND	ND	ND	ND	ND	ND
Bromomethane	ND	ND	ND	ND	ND	ND	ND	ND	ND	ND	ND
Chloroethane	ND	ND	ND	ND	ND	ND	ND	ND	ND	ND	ND
Freon 11	ND	0.00026	0.00097	0.00022	0.00035	0.0008	0.00037	0.00037	0.0002	ND	ND
cis-1,2-Dichloroethane	ND	ND	ND	ND	ND	ND	ND	ND	ND	ND	ND
Carbon Disulfide	ND	0.00035	ND	ND	ND	0.00066	0.00035	ND	0.00029	ND	ND
Freon 113	ND	ND	ND	ND	ND	ND	ND	ND	ND	ND	ND
Acetone	0.011	0.0062	ND	0.033	0.270	0.020	0.0088	0.019	0.011	0.0012	0.0013
Methylene Chloride	0.0015	0.00047	0.0044	0.00038	0.0017	0.0008	0.00067	0.00042	0.00032	ND	ND
Trans-1,2-Dichloroethene	ND	ND	ND	ND	ND	ND	ND	ND	ND	ND	ND
1,1-Dichloroethane	ND	ND	ND	ND	ND	ND	ND	ND	ND	ND	ND
Vinyl Acetate	ND	ND	ND	ND	ND	ND	ND	ND	ND	ND	ND
1,1-Dichloroethene	ND	ND	ND	ND	ND	ND	ND	ND	ND	ND	ND
2-Butanone	0.017	0.0035	0.017	0.0053	0.048	0.0036	ND	0.0029	0.0021	ND	ND
Chloroform	ND	ND	ND	ND	0.00017	0.0006	0.00027	0.00021	0.00016	ND	ND
1,1,1-Trichloroethane	ND	ND	ND	ND	ND	ND	ND	ND	ND	ND	ND
Carbon Tetrachloride	ND	ND	ND	ND	ND	ND	ND	ND	ND	ND	ND
Benzene	0.00086	0.0022	0.0024	0.00038	0.0022	0.0014	0.00082	0.00069	0.001	ND	ND
1,2-Dichloroethane	ND	ND	ND	ND	ND	ND	ND	ND	ND	ND	ND
Trichloroethene	ND	ND	0.00022	0.00022	0.00026	0.0011	0.00026	0.00021	0.00018	ND	ND
1,2-Dichloropropane	ND	ND	ND	ND	ND	ND	ND	ND	ND	ND	ND
Bromodichloromethane	ND	ND	ND	ND	ND	ND	ND	ND	ND	ND	ND
cis-1,3-Dichloropropene	ND	ND	ND	ND	ND	ND	ND	ND	ND	ND	ND
4-Methyl-2-Pentanone	0.0014	0.0023	0.0038	0.0044	0.0017	0.00079	ND	ND	ND	ND	ND

**Table 4. Volatile Organic Compounds (Continued)**

*ND – None Detected	1/15/2005	1/16/2005	1/16/2005	1/17/2005	2/7/2005	2/19/2005	2/19/2005	2/20/2005	2/20/2005	2/21/2005	2/21/2005
	#1 mini can	116 G	116 SM	117 G	MC27	219KA	219OB	220KA	220R	222KA	222AI
Analyte	PPM	PPM	PPM	PPM	PPM	PPM	PPM	PPM	PPM	PPM	PPM
Toluene	0.0065	0.069	0.0062	0.0028	0.0071	0.0043	0.015	0.022	0.0019	ND	ND
Trans-1,3-Dichloropropene	ND	ND	ND	ND	ND	ND	ND	ND	ND	ND	ND
1,1,2-Trichloroethane	ND	ND	ND	ND	ND	ND	ND	ND	ND	ND	ND
Tetrachloroethene	0.0011	0.00024	0.00073	ND	0.0005	0.00052	0.00053	ND	ND	ND	ND
2-Hexanone	ND	ND	ND	ND	ND	0.00064	ND	2	ND	ND	ND
Dibromochloromethane	ND	ND	ND	ND	ND	ND	ND	ND	ND	ND	ND
1,2-Dibromoethane	ND	ND	ND	ND	ND	ND	ND	ND	ND	ND	ND
Chlorobenzene	ND	ND	ND	ND	ND	ND	ND	ND	ND	ND	ND
Ethylbenzene	0.001	0.045	0.0011	0.00035	0.011	0.001	0.0082	0.014	0.0005	ND	ND
m,p-Xylene	0.0041	0.220	0.0048	0.0015	0.030	0.0035	0.035	0.067	0.0023	ND	ND
o-Xylene	0.0015	0.110	0.0017	0.00063	0.0075	0.0013	0.018	0.034	0.00072	ND	ND
Styrene	0.0057	0.00055	0.0014	0.00043	0.00046	0.00078	0.00028	0.00049	0.00022	ND	ND
Bromoform	ND	ND	ND	ND	ND	ND	ND	ND	ND	ND	ND
1,1,1,2-Tetrachloroethane	ND	ND	ND	ND	ND	ND	ND	ND	ND	ND	ND
Benzyl Chloride	ND	ND	ND	ND	ND	ND	ND	ND	ND	ND	ND
4-Ethyl toluene	0.00025	0.034	0.00039	ND	0.00072	0.00088	0.0027	0.00028	0.0002	ND	ND
1,3,5-Trimethylbenzene	0.00027	0.051	0.00041	ND	0.0012	0.00057	0.0034	0.015	0.00019	ND	ND
1,2,4-Trimethylbenzene	0.00089	0.220	0.0017	0.00061	0.0031	0.001	0.012	0.064	0.00043	ND	ND
1,3-Dichlorobenzene	ND	ND	ND	ND	ND	ND	ND	ND	ND	ND	ND
1,4-Dichlorobenzene	ND	ND	ND	ND	0.00024	0.00046	0.00022	0.00021	0.00016	ND	ND
1,2-Dichlorobenzene	ND	ND	ND	ND	ND	ND	ND	ND	ND	ND	ND
1,2,4-Trichlorobenzene	ND	ND	ND	ND	ND	ND	ND	ND	ND	ND	ND
Hexachlorobutadiene	ND	ND	ND	ND	ND	ND	ND	ND	ND	ND	ND
Methyl t-Butyl Ether	ND	ND	ND	ND	ND	ND	ND	ND	ND	ND	ND
Total Petroleum Hydrocarbon	0.034	0.630	0.070	0.018		0.030	0.092	0.220	0.017	0.00043	ND



**Table 5. ATSDR Minimal Risk Levels (MRLs) December 2004**

Analyte	ATSDR Minimal Risk Levels (MRLs) December 2004
Dichlorodifluoromethane	
Chloromethane	<b>Inh</b> Acute-0.5ppm, Int-0.2ppm, Chr-.05ppm
Freon 114	
Vinyl Chloride	<b>Inh</b> Acute-0.5ppm, Int-0.3ppm, <b>Oral</b> Chr-0.003 mg/kg/day
Bromomethane	<b>Inh</b> Acute-0.05ppm, Int-0.05ppm, Chr-0.005ppm, <b>Oral</b> Int-0.003 mg/kg/day
Chloroethane	<b>Inh</b> Acute-15ppm
Freon 11	
Cis-1,2-Dichloroethane	<b>Oral</b> Acute-1 mg/kg/day, Int-0.3 mg/kg/day
Carbon Disulfide	<b>Inh</b> Chr-0.3ppm, <b>Oral</b> Acute-0.01 mg/kg/day
Freon 113	
Acetone	<b>Inh</b> Acute-26ppm, Int-13ppm, Chr-13ppm, <b>Oral</b> Int-2 mg/kg/day
Methylene Chloride	<b>Inh</b> Acute-0.6ppm, Int-0.3ppm, Chr-0.3ppm, <b>Oral</b> Acute-0.2 mg/kg/day, Chr-0.06 mg/kg/day
trans-1,2-Dichloroethene	<b>Inh</b> Acute-0.2ppm, Int-0.2ppm, <b>Oral</b> Int-0.2 mg/kg/day
1,1-Dichloroethane	
Vinyl Acetate	<b>Inh</b> Int-0.01ppm
1,1-Dichloroethene	<b>Inh</b> Int-0.02ppm, <b>Oral</b> Chr-0.009 mg/kg/day
2-Butanone	
Chloroform	<b>Inh</b> Acute-0.1ppm, Int-0.05ppm, Chr-0.02ppm, <b>Oral</b> Acute-0.3mg/kg/day, Int-0.1mg/kg/day, Chr-0.01mg/kg/day
1,1,1-Trichloroethane	<b>Inh</b> Acute-2ppm, Int-0.7ppm, <b>Oral</b> Int-20mg/kg/day
Carbon Tetrachloride	<b>Inh</b> Int-0.03ppm, Chr-0.03ppm, <b>Oral</b> Acute-0.05mg/kg/day, Int-0.02mg/kg/day
Benzene	<b>Inh</b> Acute-0.05ppm, Int-0.004ppm
1,2-Dichloroethane	<b>Inh</b> Chr-0.6ppm, <b>Oral</b> Int-0.2mg/kg/day
Trichloroethene	<b>Inh</b> Acute-2ppm, Int-0.1ppm, <b>Oral</b> Acute-0.002mg/kg/day
1,2-Dichloropropane	<b>Inh</b> Acute-0.05ppm, Int-0.007ppm, <b>Oral</b> Acute-0.1mg/kg/day, Int-0.07mg/kg/day, Chr-0.09mg/kg/day
Bromodichloromethane	<b>Oral</b> Acute-0.04mg/kg/day, Chr-0.02mg/kg/day
Cis-1,3-Dichloropropene	<b>Inh</b> Int-0.003ppm, Chr-0.002ppm
4-Methyl-2-Pentanone	
Toluene	<b>Inh</b> Acute-1ppm, Chr-0.08ppm, <b>Oral</b> Acute-0.8mg/kg/day, Int-0.02mg/kg/day
trans-1,3-Dichloropropene	
1,1,2-Trichloroethane	<b>Oral</b> Acute-0.3mg/kg/day, Int-0.04mg/kg/day
Tetrachloroethene	<b>Inh</b> Acute-0.2ppm, Chr-0.04ppm, <b>Oral</b> Acute-0.05mg/kg/day
2-Hexanone	
Dibromochloromethane	
1,2-Dibromoethane	
Chlorobenzene	<b>Oral</b> Int-0.4mg/kg/day
Ethylbenzene	<b>Inh</b> Int-1.0ppm
m,p-Xylene	<b>Inh</b> Acute-1.0ppm, Int-0.7ppm, Chr-.0.1ppm <b>Oral</b> Int-0.2mg/kg/day
o-Xylene	<b>Inh</b> Acute-1.0ppm, Int-0.7ppm, Chr-.0.1ppm <b>Oral</b> Int-0.2mg/kg/day
Styrene	<b>Inh</b> Chr-0.06ppm, <b>Oral</b> Int-0.2mg/kg/day
Bromoform	<b>Oral</b> Acute-0.7mg/kg/day, Int-0.2mg/kg/day, Chr-0.2mg/kg/day
1,1,2,2-Tetrachloroethane	<b>Inh</b> Int-0.4ppm, <b>Oral</b> Int-0.6mg/kg/day
Vinyl Chloride	<b>Inh</b> Acute-0.5ppm, Int-0.3ppm, <b>Oral</b> Chr-0.003 mg/kg/day

**Table 5. ATSDR Minimal Risk Levels (MRLs) December 2004 (Continued)**

Analyte	ATSDR Minimal Risk Levels (MRLs) December 2004
Benzyl Chloride	
4-Ethyl toluene	
1,3,5-Trimethylbenzene	
1,2,4-Trimethylbenzene	
1,3-Dichlorobenzene	<b>Oral</b> Acute-0.4mg/kg/day, Int-0.03mg/kg/day
1,4-Dichlorobenzene	<b>Inh</b> Acute-2ppm, Int.-0.1ppm, Chr-0.02ppm, <b>Oral</b> Int-0.07mg/kg/day
1,2-Dichlorobenzene	<b>Oral</b> Acute-0.8mg/kg/day, Int-0.4mg/kg/day, Chr.-0.4mg/kg/day
1,2,4-Trichlorobenzene	
Hexachlorobutadiene	<b>Oral</b> Int-0.0002mg/kg/day
Methyl t-Butyl Ether	<b>Inh</b> Acute-2ppm, Int-0.7ppm, Chr-0.7ppm, <b>Oral</b> Acute-0.4mg/kg/day, Int-0.3mg/kg/day

#### E. Elemental and Organic Carbon Results

A total of 16 personal and area samples for elemental and organic carbon were collected. During the Martin Luther King weekend on January 15, 16, and 17, 2005, five personal samples and one area sample were collected at the West Entrance kiosks and one area sample was collected at the Madison Warming Hut. Two personal samples were collected at the Mammoth Maintenance Shop on February 7, 2005. Four personal samples and two area samples were collected at the West Entrance kiosks, and one area sample was collected at the Madison Warming Hut during President's Day weekend on February 19, 20, and 21, 2005. Samples were analyzed for elemental and organic carbon using evolved gas analysis (EGA) by thermal-optical analyzer. There are currently no PELs, TLVs, or RELs for elemental or organic carbon. All samples were well below TLVs proposed by ACGIH in 1996 and 2001 (see Appendix C Table 1C).

#### F. Oxides of Nitrogen Results

A total of eight area samples were collected for nitrogen dioxide and nitric oxide. During the Martin Luther King weekend on January 15, 16, and 17, 2005, three area samples were collected at the West Entrance kiosks and one area sample was collected at the Madison Warming Hut. One area sample was collected at the Mammoth Maintenance Shop on February 7, 2005. Three area samples were collected at the West Entrance kiosks during President's Day weekend on February 19, 20, and 21, 2005. Samples were analyzed using visible absorption spectrophotometry for nitric oxide (NO) and nitrogen dioxide (NO<sub>2</sub>). All samples were below established occupational exposure limits for NO and NO<sub>2</sub> (see Appendix C Table 1D). ATSDR does not have an MRL for these compounds. Sample 220N2, collected at kiosk A on February 20, 2005, showed a time weighted average (TWA) NO<sub>2</sub> concentration of 0.97 ppm. This level approached the NIOSH short term exposure limit of 1.0 ppm.

NO<sub>2</sub> was also measured using an Industrial Scientific iTX<sup>®</sup> Multi-Gas Monitor<sup>™</sup>. The results of the NO<sub>2</sub> direct reading monitoring are shown in Table 6. These results were below applicable occupational exposure limits.

**Table 6. Real Time Nitrogen Dioxide Concentrations**

Date	Location	Start	Stop	NO <sub>2</sub> Avg (ppm)	NO <sub>2</sub> 8 Hour TWA	NO <sub>2</sub> Peak (STEL)
1/15/2005	Kiosk A	8:19 AM	1:03 PM	0.00	0.00	0.1 ppm @ 9:55 AM
1/16/2005	Kiosk A	7:39 AM	12:57 PM	0.16	0.11	0.2 ppm @ 10:03 AM
1/17/2005	MWH <sup>1</sup>	8:20 AM	11:24 AM	0.00	0.00	0.0 ppm @ 11:13 AM
2/07/2005	MMS <sup>2</sup>	8:04 AM	11:22 AM	0.00	0.00	0.0 ppm @ 8:04 AM
2/19/2005	Kiosk A	7:36 AM	12:50 PM	0.00	0.00	0.0 ppm @ 7:36 AM
2/20/2005	Kiosk A	6:54 AM	2:03 PM	0.00	0.00	0.0 ppm @ 1:58 PM
2/21/2005	Kiosk A	7:23 AM	12:35 PM	0.19	0.13	0.2 ppm @ 10:47 AM

<sup>1</sup>Madison Warming Hut; <sup>2</sup>Mammoth Maintenance Shop

#### G. Carbon Monoxide Results

Carbon monoxide (CO) was measured using an Industrial Scientific iTX<sup>®</sup> Multi-Gas Monitor<sup>™</sup>. The results of the CO monitoring are shown in Table 7. The OSHA PEL for CO is 50 ppm and the ACGIH TLV is 25 ppm. The NIOSH REL for CO is 35 ppm with a 200 ppm ceiling. None of the CO levels observed in this study exceeded the established occupational exposure limits.

**Table 7. Real Time Carbon Monoxide Concentrations**

Date	Location	Start	Stop	CO Avg (ppm)	CO 8 Hour TWA	CO Peak (STEL)
1/15/2005	Kiosk A	8:19 AM	1:03 PM	0.57	0.34	6.5 ppm @ 9:40 AM
1/16/2005	Kiosk A	7:39 AM	12:57 PM	0.72	0.48	8.9 ppm @ 9:36 AM
1/17/2005	MWH <sup>1</sup>	8:20 AM	11:24 AM	0.00	0.00	0.0 ppm @ 8:20 AM
2/07/2005	MMS <sup>2</sup>	8:04 AM	11:22 AM	0.29	0.12	3.5 ppm @ 11:22 AM
2/19/2005	Kiosk A	7:36 AM	12:50 PM	2.12	1.39	14.0 ppm @ 9:19 AM
2/19/2005	Kiosk B	8:10 AM	12:32 PM	0.00	0.00	0.00 ppm @ 8:10 AM
2/20/2005	Kiosk A	6:54 AM	2:03 PM	1.73	1.55	33.6 ppm @ 9:05 AM
2/20/05	PR <sup>1</sup>	8:17 AM	3:46 PM	3.74	3.33	22.2 ppm @ 9:55 AM
2/21/2005	Kiosk A	7:23 AM	12:35 PM	0.58	0.38	8.0 ppm @ 9:38 AM

<sup>1</sup>Personal Sample on Park Ranger

<sup>2</sup>Personal Sample on Park Ranger

#### H. Respirable Particulate Matter Results

A total of 13 integrated samples for respirable particulate (PM<sub>4.0</sub>) were collected. During the Martin Luther King weekend on January 15, 16, and 17, 2005, two personal samples and four area samples were collected at the West Entrance kiosks. One personal and one area sample were collected at the Mammoth Maintenance Shop on February 7, 2005. Three personal samples and two area samples were collected at the West Entrance kiosks during President's Day weekend on February 19, 20, and 21, 2005. Samples were analyzed by gravimetric analysis and all results were below the limit of detection for the

analytical method, and thus were below established occupational exposure limits (see Appendix C Table 1E).

Samples for respirable particulate were also collected using real time aerosol monitors and these results are outlined below.

I. Particle Count Data

A TSI® P-Trak was used to measure particle number concentration in kiosk A at the West Entrance and at the Madison Warming Hut. In kiosk A, the instrument was located on the north side bench on January 15 and 16, 2005. The data results are shown in Table 8 and Figure 2. Particle counts peaked during the morning hours and correlated with snowmobile traffic through the West Entrance. Average particle counts were higher in kiosk A on January 16. This day was considerably warmer than January 15, and it was observed that the kiosk window was left open for longer periods of time on January 16.

**Table 8. P-Trak particle count data in the West Entrance Kiosk A**

Date	Start Time	Stop Time	Ave. Conc. (pt./cc)	Min (pt./cc)	Time of Min	Max (pt./cc)	Time of Max
1-15-05	8:15:24	13:10:24	8056	1478	8:53:24	79622	10:25:24
1-16-05	7:57:45	13:07:45	10515	734	12:55:45	66051	9:22:45

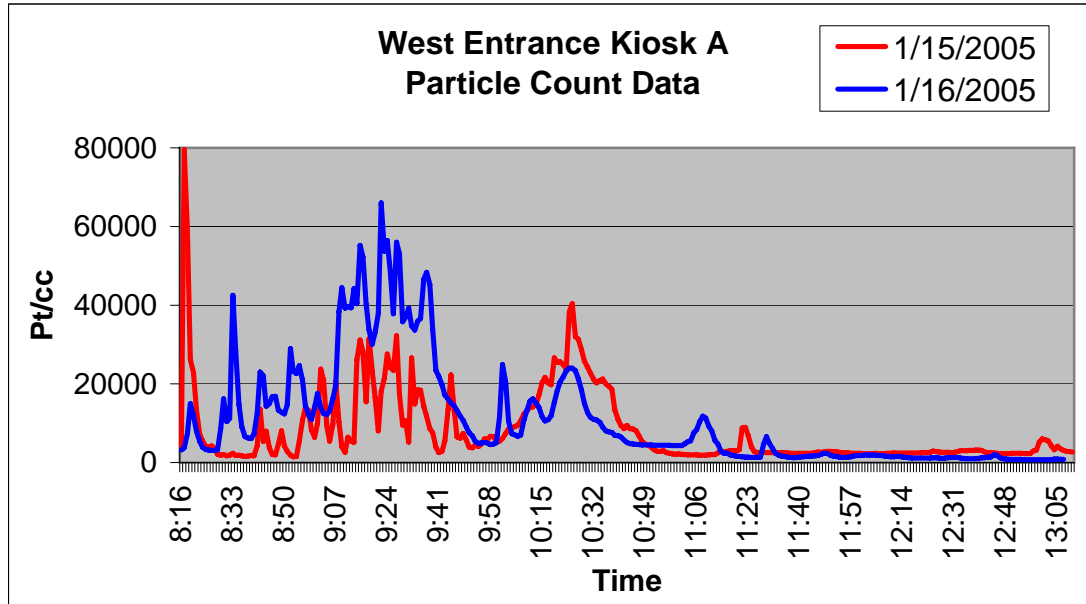

**Figure 2. Graph of particle counts with time in kiosk A at the West Entrance**

The same instrument was used to measure particle number concentration in Madison Warming Hut on January 17, 2005. The instrument was located on the bench opposite the

vending machine. The peak particle level occurred in the morning hours at 9:22 AM. The data are shown in Table 9 and Figure 3.

**Table 9. P-Trac particle count data in the Madison Warming Hut**

Date	Start Time	Stop Time	Ave. Conc. (pt./cc)	Min (pt./cc)	Time of Min	Max (pt./cc)	Time of Max
1-17-05	7:57:45	13:07:55	10515	734	12:55:45	66051	09:22:45

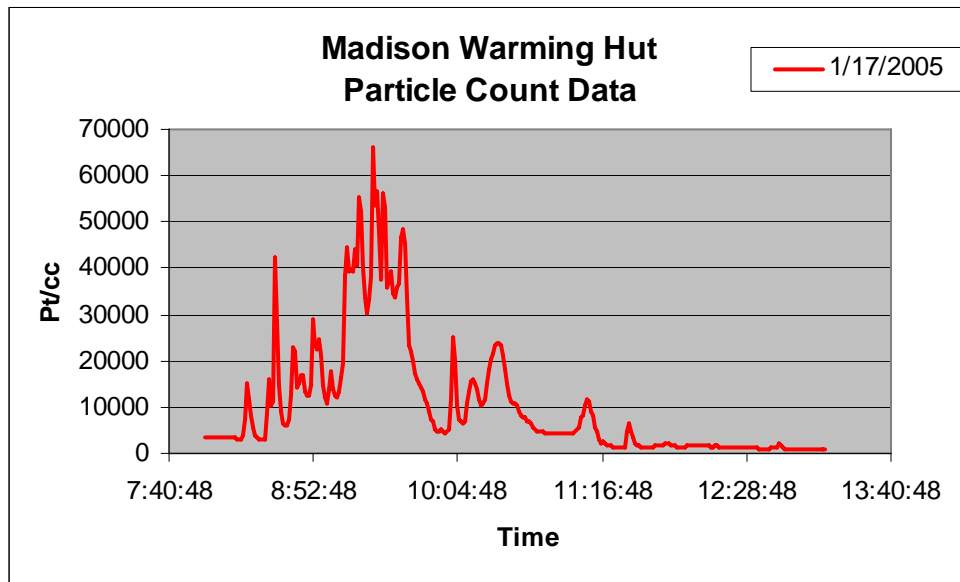

**Figure 3. Graph of particle counts with time in the Madison Warming Hut**

## 2. Particle Mass Concentration Data

A Thermo-Electron® (MIE) DataRAM™ was used to obtain real time particle mass concentration data. Previous studies have shown that PM<sub>2.5</sub> measurements from real time instruments are well correlated and highly predictive of measurements from the gravimetric sampling method for aerosols in workplace environments<sup>7</sup>. Real time PM<sub>2.5</sub> samples were collected in kiosk A at the West Entrance on January 15<sup>th</sup> and February 19<sup>th</sup>, 20<sup>th</sup>, and 21<sup>st</sup>, 2005. PM<sub>2.5</sub> samples were also collected in the Madison Warming Hut on January 17<sup>th</sup>, 2005, and in the Mammoth Maintenance Shop on February 7<sup>th</sup>, 2005. Real time PM<sub>10</sub> measurements were collected in kiosk A at the West Entrance on January 16<sup>th</sup>, 2005. The results of the real time particle concentration sampling are shown in Table 10. The data are represented graphically in Figures 4 through 10.

As can be seen in Figures 4, 5, and 8, the highest ambient particle concentrations monitored at the entrance station kiosks appear to correspond with the periods of peak snowmobile and snow coach traffic entering the park (midmorning). The same appears to be true for the ambient particle concentrations measured at the Madison Warming Hut on 2/19/05, with peak concentrations occurring during periods when many snowmobile and snow coach riders frequent the facility. It is important to note that on February 20<sup>th</sup> and 21<sup>st</sup>, 2005 ambient PM<sub>2.5</sub> particle concentrations were consistently lower at the

entrance kiosks. During these days it was observed that the snowmobile guides were stopping their vehicles approximately 20 to 30 feet in front of the kiosk window and walking to the window with their paperwork. As is shown in Figure 10, the highest ambient PM<sub>2.5</sub> particle concentrations measured during this study were observed in the Mammoth Maintenance Shop. While local exhaust is employed to control particle emissions from running diesel engines in the shop, this finding is expected given the lower dilution factor present in an enclosed building. In terms of occupational exposure, no particle size selective exposure limits exist to exclusively evaluate PM<sub>10</sub> and PM<sub>2.5</sub>. In terms of public health, while the real time monitors employed in this study are not EPA reference sampling methods, all average concentrations are well below the EPA's 24-hour National Ambient Air Quality Standards for these agents.

**Table 10. Real time particle mass concentration data**

Date	Location	Cut Point	Start Time	Stop Time	Avg. Conc (ug/m <sup>3</sup> )	Max (ug/m <sup>3</sup> )	Time of Max
1/15/2005	Kiosk A	PM <sub>2.5</sub>	8:15	13:13	3.6	15.9	10:29
1/16/2005	Kiosk A	PM <sub>10</sub>	7:42	13:21	5.2	20.3	9:19
1/17/2005	Warming Hut	PM <sub>2.5</sub>	8:24	11:24	9.9	55.6	9:05
2/7/2005	Mammoth Maint. Shop	PM <sub>2.5</sub>	8:08	11:13	27.8	77.6	10:12
2/19/2005	Kiosk A	PM <sub>2.5</sub>	6:56	12:59	4.1	17.4	8:37
2/20/2005	Kiosk A	PM <sub>2.5</sub>	6:47	13:15	1.4	13.4	13:13
2/21/2005	Kiosk A	PM <sub>2.5</sub>	7:10	12:34	1.1	13.8	11:51

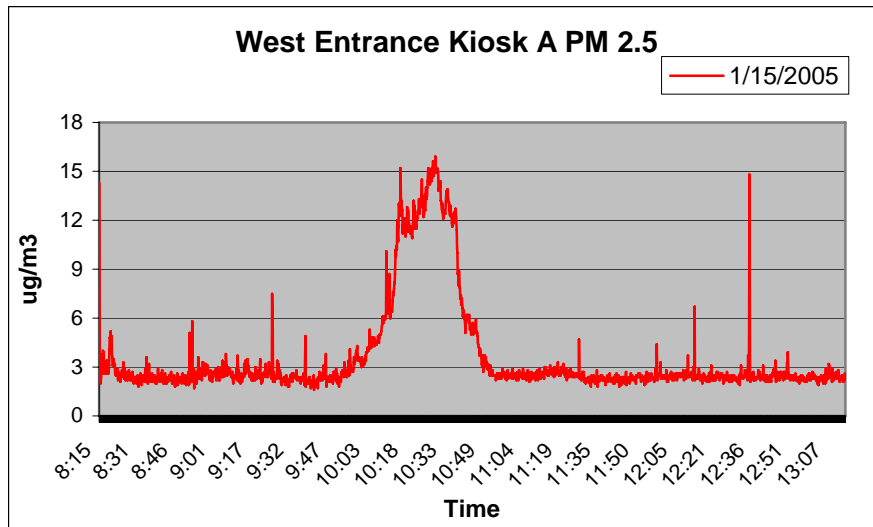

**Figure 4. Real time PM<sub>2.5</sub> particle concentrations -West Entrance Kiosk A (1/15/05)**

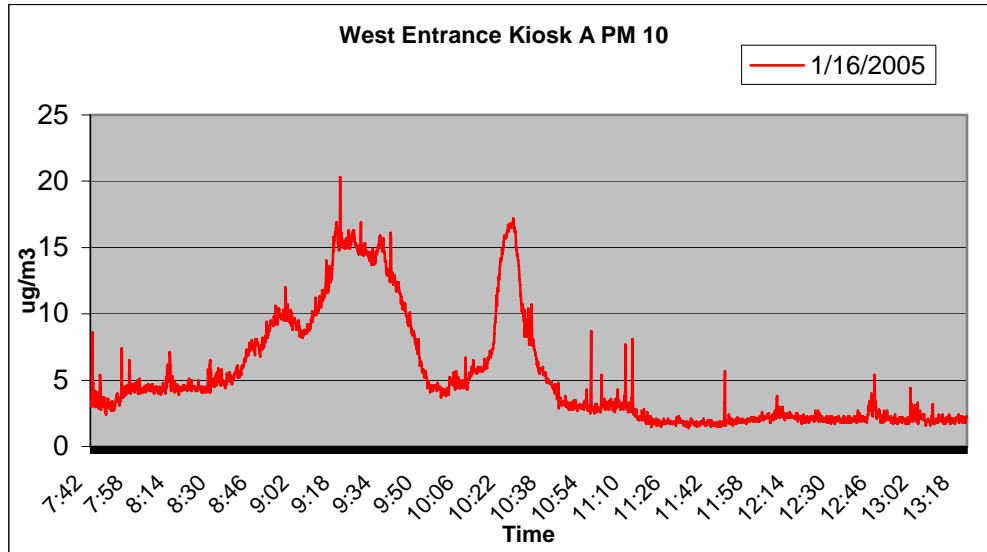

**Figure 5. Real time PM<sub>10</sub> particle concentrations - West Entrance Kiosk A (1/16/05)**

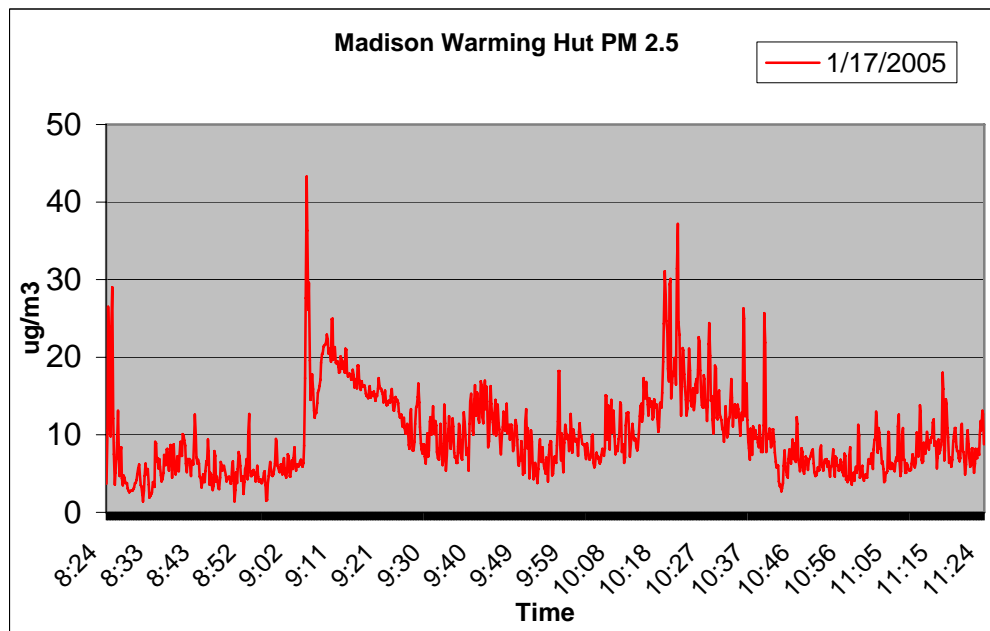

**Figure 6. Real time PM<sub>2.5</sub> particle concentrations - Madison Warming Hut (1/17/05)**

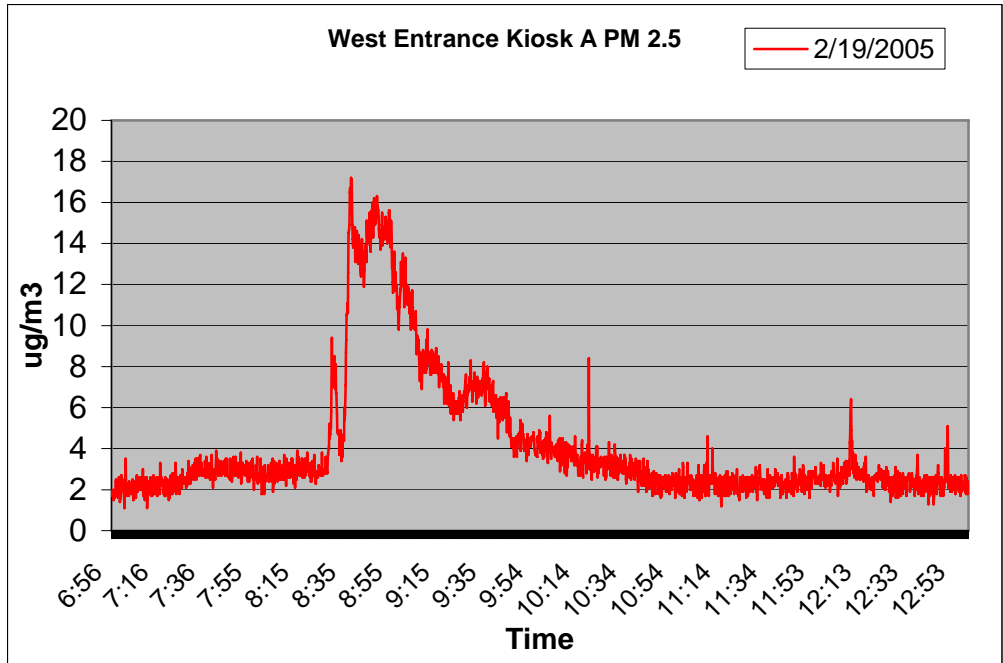

Figure 7. Real time PM<sub>2.5</sub> particle concentrations -West Entrance Kiosk A (2/19/05)

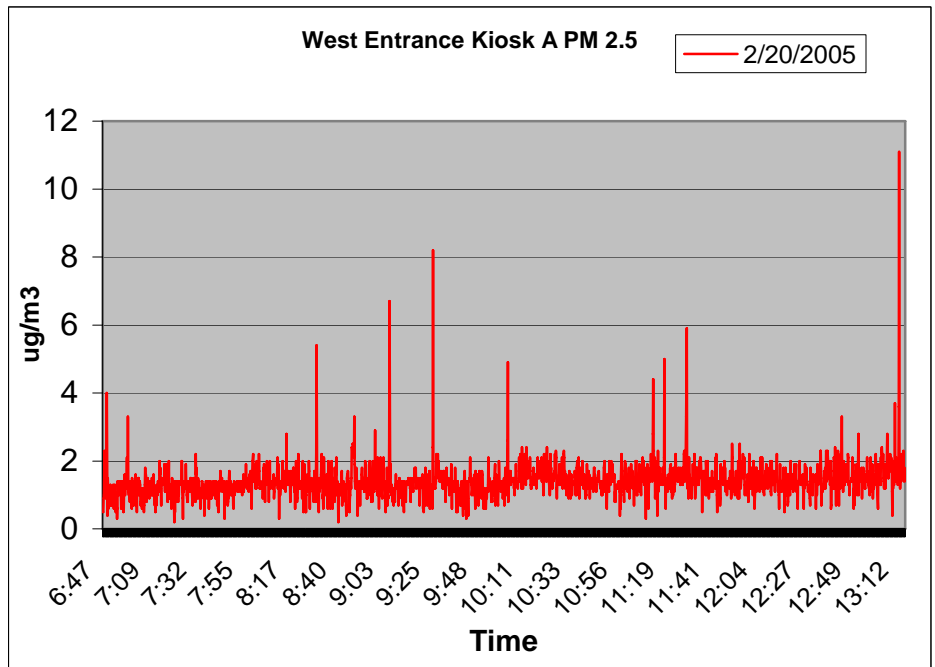
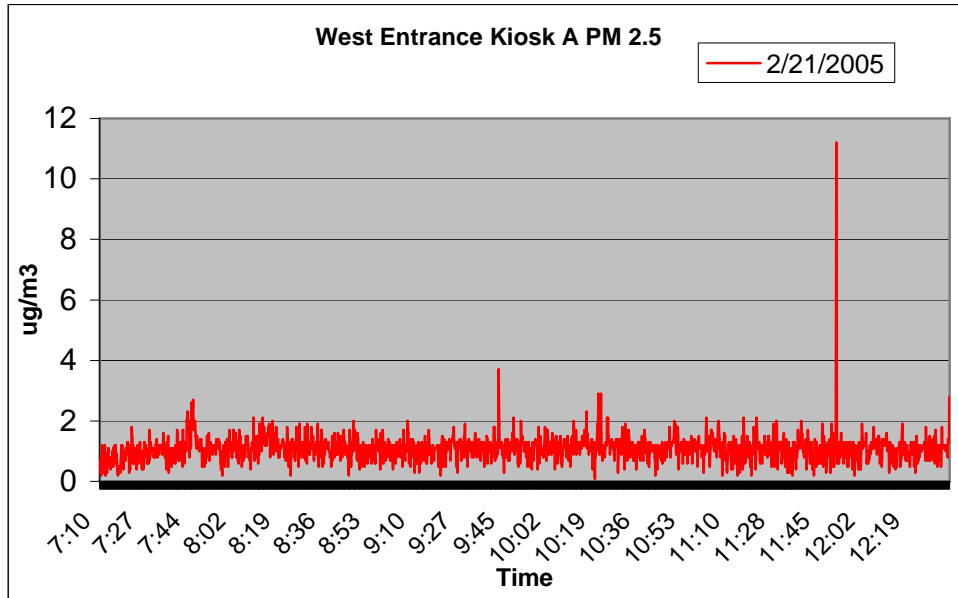
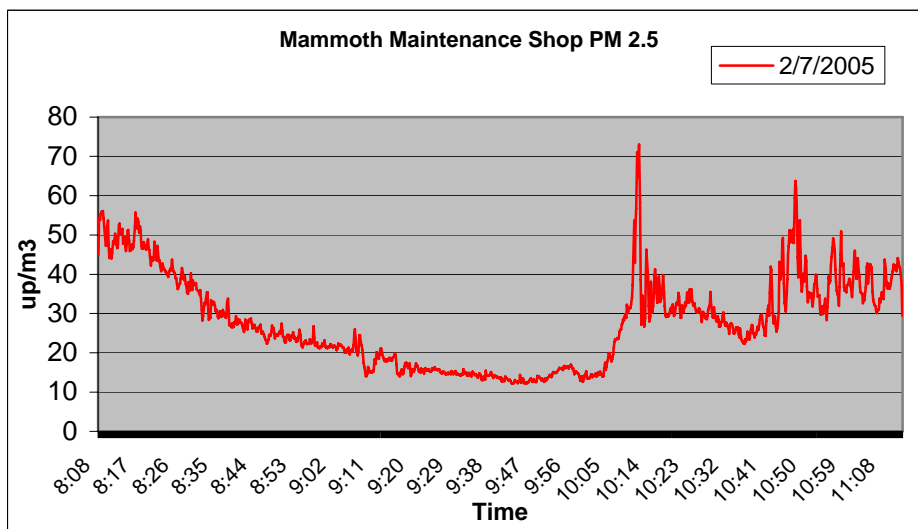

Figure 8. Real time PM<sub>2.5</sub> particle concentrations - West Entrance Kiosk A (2/20/05)





**Figure 9. Real time PM<sub>2.5</sub> particle concentrations - West Entrance Kiosk A (2/21/05)**



**Figure 10. Real time PM<sub>2.5</sub> particle concentrations - Mammoth Maint Shop (2/07/05)**

## I. Noise Results

Summarized in Table 10 are the results of personal dosimetry performed during this project. As can be seen from the results, the noise exposures received by employees monitoring snowmobile and snow coach traffic as it enters the Park and employees working in the Mammoth Maintenance Shop are well below both the OSHA Engineering Standard for noise exposure (90 dBA 8-hr TWA) and the OSHA Hearing Conservation Amendment (85 dBA 8-hr TWA). It should be noted that the investigators performing this study observed the use of hearing protection by all employees operating snowmobiles. The personal dosimetry results in Table 11 do not reflect employees wearing earplugs. Earplugs offer different levels of protection; each is specific to the manufacturer's recommendations. According to the National Park Service, the majority of the hearing protection worn in the park has a noise reduction rating (NRR) of 29 decibels. Using the OSHA recommended method for reducing noise levels using hearing protection –  $(NRR - 7) \div 2$ , would give a noise reduction of 11 decibels.

**Table 11. Personal Noise Dosimetry Results**

Date	Location	8-hr TWA (dBA) <sup>A</sup>	8-hr % Dose <sup>A</sup>	8-hr TWA (dBA) <sup>B</sup>	8-hr % Dose <sup>B</sup>
1/15/05	West Entrance Kiosk Attendants	75	12.5	67	4
1/16/05		57	1	38	<1
2/19/05		56	1	37	<1
2/20/05		55	1	35	<1
2/21/05		60	2	41	<1
1/16/05	Snowmobile Rider 1 <sup>C</sup>	85	50	83	38
1/16/05	Snowmobile Rider 2 <sup>C</sup>	85	50	83	38
1/17/05	Snowmobile Rider 1 <sup>C</sup>	90	100	89	87
1/17/05	Snowmobile Rider 2 <sup>C</sup>	91	115	86	57
2/21/05	Snowmobile Rider 1 <sup>D</sup>	79	22	61	2
2/21/05	Snowmobile Rider 2 <sup>D</sup>	83	38	N/A <sup>E</sup>	N/A <sup>E</sup>
2/7/05	Maint. Shop Helper 1	68	5	66	4
2/7/05	Maint. Shop Helper 2	71	7	70	7

<sup>A</sup> Dosimeter settings set to evaluate compliance with the OSHA Hearing Conservation Amendment (threshold = 80dB; Exchange Rate = 5 dB; Criterion Level = 90 dB; Time Constant = slow)

<sup>B</sup> Dosimeter Settings set to evaluate compliance with the OSHA Engineering Standard (threshold = 90dB; Exchange Rate = 5 dB; Criterion Level = 90 dB; Time Constant = slow)

<sup>C</sup>BAT 2003 Polaris Frontier Touring Snowmobile

<sup>D</sup>BAT 2004 Arctic Cat T660 Touring Snowmobile

<sup>E</sup>No Data Collected

## V. Comparison of the Current Study with Previous Air Quality Studies

### A. Previous Air Quality Studies

Numerous ambient and occupational air quality studies have been conducted at Yellowstone National Park. Some of these studies have indicated that standards may have been exceeded at Yellowstone National Park, particularly on those days with peak snowmobile traffic, and that the accumulation of a large number of snowmobiles in a small area can result in short-term exposures to very high levels of CO, PM, and HC (including toxic organics).<sup>2</sup>

Radtke<sup>3</sup> conducted personal exposure measurements for carbon monoxide and noise at the West Entrance to Yellowstone National Park. This study concluded that carbon monoxide and noise did not appear to be a significant hazard for employees at the West Entrance but other contaminants in the exhaust emissions should be investigated and noise exposures during snowmobile mobile patrols need to be evaluated.

A 2000 OSHA study<sup>4</sup> conducted personal and area sampling for benzene, gasoline, formaldehyde, carbon monoxide, diesel exhaust, welding fume, and noise. The study concluded that exposures were below OSHA PELs and ACGIH TLVs, but exposure of one West Entrance employee to benzene, formaldehyde, carbon monoxide, and noise exceeded NIOSH RELs. This study also found that a West District Patrol Ranger was overexposed to noise at a level of 93 decibels.

A 1999 study<sup>5</sup> in Yellowstone National Park included both fixed-site and personal exposure monitoring for particulate matter (PM), carbon monoxide, and volatile organic compounds (VOCs). The maximum time-weighted concentration of PM<sub>2.5</sub> at the West Entrance on a busy President's day weekend (*i.e.*, February 13 and February 14, 1999) was 78 ug/m<sup>3</sup> based on 4-hour morning and afternoon samples. Morning 4-hour concentrations for February 13 and 14 were 116 and 112 ug/m<sup>3</sup>, respectively. The morning concentration (nominally 8:30 a.m. to 12:30 p.m.) represented approximately 80% of the exposure and coincides with the time that approximately 90% of the snowmobiles entered the park on those days. Personal exposure measurements of PM less than 4.0 microns in size (PM<sub>4.0</sub>) were conducted on park employees in a variety of job categories. Results indicated exposure varied by job category, with a snowmobile mechanic having the greatest PM<sub>4.0</sub> exposure, followed by employees who worked the West Entrance station, and then snowmobile patrol rangers. West Entrance station employees who worked in the express lane (with more snowmobiles) had double the PM exposure of those who worked in the regular lanes. PM<sub>4.0</sub> concentrations were measured at levels up to 160 ug/m<sup>3</sup>.

The 1999 study<sup>5</sup> also found that West Entrance station employees had the greatest VOC exposure, followed by snowmobile patrol rangers, followed by a snowmobile mechanic. Of the VOCs measured, toluene had the highest relative concentration and benzene exposure for some employees could approach the RELs as established by NIOSH. The study supported "the hypothesis that Park employees and the surrounding environment

are exposed to high levels of many toxic pollutants as a result of snowmobile use within the Park”. At the time of the 1999 study<sup>5</sup>, commercial four-stroke snowmobiles did not exist and only snowmobiles powered by 2-stroke engines were being used in Yellowstone National Park.

A 2004 study<sup>6</sup> evaluated occupational exposures to aldehydes, VOCs, respirable particulate, carbon monoxide, and noise. The majority of the monitoring was conducted at the West Entrance kiosks, with some monitoring performed at the Madison Warming Hut, the Mammoth Mechanic Shop, and the Old Faithful Ranger Station. This study concluded that concentrations of all airborne contaminants were well below current standards and recommended exposure limits. However, aldehydes were detected in four samples, benzene was detected in three samples, xylene was detected in two samples, and toluene was detected in several samples. The highest toluene exposure of 66 ppm was measured on a personal sample taken at the West Entrance kiosk B. The greatest 8 hour PM<sub>4.0</sub> exposure was 0.6 mg/m<sup>3</sup> at the West Entrance kiosk A. Noise exposure for all kiosk attendants and other Park personnel not riding snowmobiles were all well below current standards. This study stated that noise exposures to park rangers and other personnel operating snowmobiles would likely exceed current exposure standards if the duration of snowmobile operation were to exceed approximately four hours per day.

#### B. Findings of Current Study

Air quality studies at Yellowstone National Park have shown a direct relationship between the number of snowmobiles entering the park and the magnitude of their emissions. In 2005, all recreational snowmobiles met the BAT requirements, and all were commercially guided. The vast majority of NPS-owned administrative snowmobiles were also BAT. It has also been observed that meteorology also plays an important role in that cold, stable atmospheric conditions with low wind speeds hinder the dispersion of air pollutants and allow them to accumulate in the immediate area of their release. Prior to the establishment of an express lane in late 1995 at Yellowstone’s West Entrance station, all snowmobiles entering the park were required to stop at one of the entrance station kiosks to pay entrance fees and receive information about the park. This resulted in long lines of snowmobiles and the accumulation of snowmobile emissions over a relatively small area leading to high levels of CO near the kiosks, particularly on days with poor dispersion conditions.<sup>2</sup>

The results of the current study indicate that occupational exposures to airborne contaminants are significantly less than exposures measured in previous studies. During the current study period in January 2005, a total of 414 snowmobiles and 52 snow coaches entered through the West Entrance during the Martin Luther King three-day weekend on January 15, 16, and 17. For the same holiday weekend in 1999<sup>5</sup>, just fewer than 1,800 snowmobiles entered through the West Entrance. During the current study period in February 2005, a total of 670 snowmobiles and 63 snow coaches entered through the West Entrance compared to over 2000 snowmobiles entering on the same dates during the 1999 study.<sup>5</sup> During the current study, there were no long lines of snowmobiles waiting to pass through the West Entrance. Groups of snowmobiles ranging

from one machine to approximately 15 machines would approach the West Entrance at various times staggered throughout the morning hours. Many, but not all, snowmobile guides and snow coach drivers would shut off their vehicles when they reached the kiosk window. As mentioned previously in this report, during the February monitoring activities, it was observed that many of the snowmobile guides would stop their machines 20 feet before the kiosks and walk to the window. This practice appeared to reduce the airborne emission exposure to kiosk attendants.

As stated previously, an attempt was made to obtain worst case sampling data. Due to the absence of inversions noted during the monitoring dates of the current study, worst-case data were not collected. High temperatures ranged from 26, 28, and 29 degrees Fahrenheit (<sup>0</sup>F) on January 15, 16, and 17 respectively. Low temperatures ranged from -23, -8, and 15 <sup>0</sup>F on January 15, 16, and 17 respectively. Winds were calm on all three days and January 16 was the only day which received precipitation (0.028 inches of moisture, 4 inches of snow). On February 19, 20, and 21, high temperatures ranged from 35, 31, and 25 degrees (<sup>0</sup>F) respectively. Low temperatures ranged from 4, 1, and -1 <sup>0</sup>F on February 19, 20, and 21 respectively. Winds were approximately 7 miles per hour (MPH) on February 19, 10 MPH on February 20, and calm on February 21.

PM<sub>4.0</sub> sampling during the current study was performed according to the same methods as those during the 1999 and 2004 studies<sup>5,6</sup>. In these previous studies, maximum 8-hour PM<sub>4.0</sub> TWA concentrations were measured 0.16 mg/m<sup>3</sup> and 0.6 mg/m<sup>3</sup> at the West Entrance kiosks respectively. All eleven PM<sub>4.0</sub> samples collected at the West Entrance kiosks during the current study showed concentrations below the limit of detection for the analytical method. Five of these samples were personal samples and represent employee exposure when they were either in the kiosks, out checking the snowmobiles, or in the office. The PM<sub>2.5</sub> measurement methods and sampling locations differed between the current study and the 1999 study,<sup>5</sup> and are not directly comparable. However, both the eight hour average PM<sub>2.5</sub> concentrations and peak PM<sub>2.5</sub> concentrations in the West Entrance kiosks were significantly lower in the current study. Additionally, a review of the PM<sub>2.5</sub> monitoring data from the Yellowstone National Park West Entrance ambient air monitoring station for February 19, 20, and 21, 2005, showed a maximum concentration of 7.0 ug/m<sup>3</sup>.

The results of the current study are similar to the 2004 study<sup>6</sup> in that exposures to aldehydes, BETX, VOCs, and PM<sub>4.0</sub> concentrations were well below current occupational standards and recommended exposure limits. However, in the current study, all integrated samples for aldehydes, specific BETX compounds, and PM<sub>4.0</sub> concentrations were less than the limit of detection. The 2004 study<sup>6</sup> found detectable levels of aldehydes, PM<sub>4.0</sub> concentrations, and specific BETX compounds, including an exposure to toluene of 66 ppm at the West Entrance kiosk B.

In the current study, VOCs were detected in the parts per billion range, and all reported analytical concentrations were changed to parts per million in Table 3, and each of the levels were below the Minimal Risk Levels (MRLs). The 1999 study<sup>5</sup> reported that the average maximum exposure to benzene for the West Entrance employees was 0.09 ppm,

and the median benzene exposure to this same group of workers was 0.059 ppm. The study also stated that benzene exposure for some employees could approach the RELs as established by NIOSH, and that MRLs for benzene were exceeded by five employees at the West Entrance, one mobile patrol employee, and the mechanic. The methods of sampling for VOCs in the current study were different from those performed during the 1999 study.<sup>5</sup> In the current study, active sampling was employed using sorbent tubes for personal sampling and mini-canisters equipped with pressure regulators for area sampling and all sampling results were integrated over an 8-hour work shift. In the 1999 study<sup>5</sup>, passive vapor badges were used to perform personal sampling and Tedlar bags were used to evaluate area sampling peak (15 minute) exposures. The limit of detection for the passive vapor badge sampling was not given in the report, but it is assumed to be similar to the limits of detection for the solid sorbent tubes used in the current study. The mini-canisters used in the current study and the Tedlar bags used in the 1999 study<sup>5</sup> both employed analytical method TO-15.

The results of carbon monoxide and noise exposure received by Park Service Personnel were similar to those found in previous studies. The only noise concern relates to the riders of snowmobiles whose 8-hour TWAs exceeded the OSHA Hearing Conservation Amendment and approached the OSHA Engineering Standard.

Retrofitting the air intake system at the kiosks appeared to significantly reduce employee exposure. This retrofitting took place in 2003 and consisted of extending the air intake from behind the office building at a distance of approximately 115 feet and performing preventive maintenance on the system. Thus, properly ventilated entrance station booths are an important consideration in protecting employee health. Air is supplied to the kiosks through a 24 inch duct with the intake 115 feet from the entrance station. Refer to Appendix F, figures 2 and 3 for pictures and a brief description of the kiosks at the West Entrance. During the February monitoring schedule, a ventilation survey was performed in kiosks A and B at the West Entrance. The survey showed that both kiosks are under strong positive pressure. At the time of the survey, both kiosks were achieving slightly over one air exchange per minute with the window opened 30 inches.

## **VI. Risk Assessment**

### **A. Occupational Exposure**

Vehicle exhaust, including that from snowmobiles, contains numerous toxic compounds. The focus of the current study was to evaluate occupational exposure to toxic air pollutants and noise emitted by snowmobiles operating in Yellowstone National Park. The sampling strategies employed were designed to assess occupational exposures through a combination of personal and area sampling. Our sampling strategy was not designed to specifically address non-occupational exposures to toxic air pollutants and noise emitted by snowmobiles.

The results of the current study suggest that occupational exposures to all contaminants, with the exception of noise, are well below current standards and recommended

occupational exposure limits. These monitoring results also indicate that levels of individual pollutants, including carcinogens such as benzene, resulting from the combustion of 4-stroke snowmobile engines, appear to be less than Minimal Risk Levels (MRLs) established by ATSDR. An MRL is an estimate of the daily human exposure to a hazardous substance that is likely to be without appreciable risk of adverse non-cancer health effects over a specified duration of exposure. These substance specific estimates, which are intended to serve as screening levels, are used by ATSDR health assessors and other responders to identify contaminants and potential health effects that may be of concern at hazardous waste sites. MRLs are based on either acute (1 to 14 days), intermediate (15 to 365 days), or chronic (365 days or more) exposure duration.

The average benzene concentration based on the current study's mini-canister samples was 0.0013 ppm, (4.0 ug/m<sup>3</sup>). A Park employee exposed to 4.0 ug/m<sup>3</sup> benzene for a 20-year employment period would be exposed to approximately 44,200 ug of benzene (4.0 ug/m<sup>3</sup> x 10 m<sup>3</sup>/day x 65 days/year x 20 years). Under this scenario, the average daily mass of benzene attributable to snowmobile emissions for an employee who is exposed for 20 years of a 70 year total life would be 44,200 ug / (365 days/year x 70 years) = 1.7 ug/day.

For perspective purposes, for a 70 year lifetime of exposure to benzene at 1 ug/m<sup>3</sup>, the unit risk is approximately 2 to 8 per million (2 to 8 x 10<sup>-6</sup>).<sup>8</sup> For non-occupational exposure to benzene at an average concentration of 1.0 ug/m<sup>3</sup> and a breathing volume of 20 m<sup>3</sup>/day, the total amount of benzene mass inhaled per day would be 20 ug (1.0 ug/m<sup>3</sup> x 20 m<sup>3</sup>/day). In the sample calculation above, and assuming working 65 working days per year, and a working lifetime of 20 years, a winter season exposure to an average benzene concentration of 4 ug/m<sup>3</sup> would result in a risk approximately 0.1 times the unit risk [(2.0 ug/day)/(20 ug/day)].

There are many uncertainties associated with risk assessment. The exposure assessment in the current study involved a limited time period. Although this time period was thought to represent worst-case exposures, it cannot be construed to represent all possible exposure scenarios to snowmobile emissions and/or other toxic contaminants that Park employees may encounter at work or during non-occupational activities. The current study focused on winter use exposure conditions for a small number of Park employees.. Worker exposure to gasoline and diesel powered vehicle emissions during other seasons of the year could increase cancer and non-cancer risks. The current study focused on integrated shift exposure and did not evaluate short-term peak exposures for the gaseous/vapor contaminants. EPA cancer risk estimates are based on a lifetime or prolonged exposure. Exposure to high concentrations for short time periods presents uncertainties in assessing risk. Studies have indicated that short-term exposures at higher doses may increase cancer risk beyond that of an equivalent dose administered over a longer period of time.<sup>5, 10</sup>

This exposure assessment was conducted for a limited number of toxic contaminants. In addition, there is limited data available to estimate the risk of adverse health effects from exposures to chemical mixtures. While it is recognized that the effect most commonly

observed when two chemicals are administered together is additive; synergistic, potentiation, and antagonistic effects may also arise from the cumulative, simultaneous exposure to various air pollutants.<sup>8,11</sup> Therefore, it is important that employee and public exposure to exhaust gases and vapors be minimized.

## B. Public Exposure

The sampling strategy in the current study was not designed to specifically address non-occupational exposures to toxic air pollutants and noise emitted by snowmobiles. Consequently, it is not possible to directly apply the results of this study to public exposure.

The level of exposure experienced by workers or the general population is a function of the environment, the receptors, and any resulting interactions between the two. Environmental factors that must be considered include the sources of the chemicals and the nature of the exposure. If it is indirect exposure, then the pathways for transfer and the impact of environmental conditions on that transfer must be considered. Wide variations in concentration and receptor characteristics may exist, even within a single scenario. In occupational settings contaminant concentrations are characterized as the highest concentration (8-hour time-weighted average or ceiling level). The approach in environmental risk assessment is to develop an estimate of the high-end concentration (e.g., upper 95% confidence level) and the mean concentration.

Occupational exposure limits such as PELs, TLVs and RELs are generally set for “healthy workers.” In most cases, they do not take into account the variable susceptibility of individual employees with preexisting health problems or genetic risk factors. The public health based values of ATSDR and EPA are generally much lower than the occupational exposure limits. This arises from a variety of considerations, including the potential for exposure to vulnerable populations, such as the sick, the elderly and the very young. In addition, environmental exposure limits consider a continuous or 24 hour a day exposure. There is a general attitude that risk rates for the public should be considerably lower than risk rates acceptable in an occupational setting.<sup>12</sup>

The level of exposure to a chemical will be influenced by the characteristics of the receptors, such as activities, age, size, etc. Occupational exposure to a chemical may be higher than casual recreational exposure to the same chemical in the environment. Occupational exposures are generally higher than environmental exposures because of the activities performed by workers and their proximity to the source. As described above, occupational exposure limits are usually much higher than the public health based values because workers are considered to be healthier than the general population and their exposures are assumed to be limited to the shift duration. Additionally, it is assumed that workplace exposures will be reduced through the use of engineering, administrative, and personal protective equipment controls.

In the views of the authors, public exposure to snowmobile and snowcoach emissions in Yellowstone National Park consist of the following:



- People that ride snowmobiles under the supervision of a guide.
- People riding in snowcoaches.
- Cross-country skiers or people on snow shoes who enter the park by the above two methods or on their own.

National Park Service Employees, snowmobile guides, snowcoach drivers, and contractors are not considered by these authors as being in a public exposure category. These employees would have exposure to snowmobile and snowcoach emissions for a significant greater number of days per season than the general public.

In the current study, VOCs were detected in the parts per billion concentration range. Samples collected in the West Entrance kiosks and personal samples on Park rangers operating snow machines showed reported analytical concentrations below the Minimal Risk Levels (MRLs). If the current study results are truly representative of worker exposure to VOCs from snowmobile emissions during winter use activities, it is reasonable to assume that public exposure to snowmobile emissions will be less than established MRLs. As noted above, peak exposures to VOCs were not evaluated. Peak exposures to snowmobile emissions will most likely occur to workers and the public and the effect of these peak exposures on health risks is unknown.

## **VII. Conclusions and recommendations**

- A. Worker exposure to toxic air contaminants were below established occupational standards and established recommended exposure limits.
- B. Worker exposure to toxic air contaminants were less than Minimal Risk Levels (MRLs) established by ASDTR.
- C. The results of the current study indicate that occupational exposures to airborne contaminants are less than exposures measured in previous studies. The reduction in exposure levels mostly likely results from the use of 4-stroke snowmobiles and the reduction in the number of snowmobiles entering the Park. The numbers of snowmobiles entering the West Entrance at the times of study were less the allowable limit. An increase in snowmobile traffic to the allowable limit may increase exposures.
- D. Noise exposures received by employees monitoring snowmobile and snow coach traffic as it enters the Park and employees working in the Mammoth Maintenance Shop are below both the OSHA Engineering Standard for noise exposure (90 dBA 8-hr TWA) and the OSHA Hearing Conservation Amendment (85 dBA 8-hr TWA).
- E. In all but two samples, the 8-hour projected TWA results of employees riding snowmobiles exceeded the OSHA Hearing Conservation Amendment and for the same samples approached the OSHA Engineering Standard. Park Service

employees operating snowmobiles would likely exceed the OSHA engineering standard and the OSHA Hearing Conservation Amendment if the duration of snowmobile operation were to exceed approximately 7 hours and 4½ hours, respectively.

- F. Personal exposure monitoring of Park employees for snowmobile emissions should be expanded in both time and job classes to obtain a more representative distribution of exposures.
- G. Future research should consider the bioassay of human samples such as blood and/or urine for xenobiotics or metabolites of selected xenobiotics. This would provide information on the employees' body burden of selected contaminants for correlation with airborne exposure data.
- H. Personal exposure monitoring for gasoline and diesel emission contaminants should be conducted on Park personnel during the summer months. Sampling should include analysis for size-selective particulate matter, elemental carbon, particulate organic carbons, and selected vapor phase VOCs such as oxygenated polynuclear aromatic hydrocarbons.

## References

1. Federal Register / Vol. 69, No. 217 / Wednesday, November 10, 2004 / Rules and Regulations.
2. U.S. Department of the Interior, National Park Service, Air Resources Division, Denver, Colorado, Air Quality Concerns Related to Snowmobile Usage in National Parks, February 2000.
3. Industrial Hygiene Consultation Report. Project Number: Report Number: 970101. Tim Radtke. Department of Interior, Office of Managing Risk and Public Safety, Lakewood, Colorado, June 1997
4. U.S. Department of Labor, OSHA, Billings Area Office. Industrial Hygiene Survey of Park Employees Exposures During Winter Use at Yellowstone National Park, February 19 through February 14, 2000.
5. Environmental and Occupational Exposure to Toxic Air Pollutants from Winter Snowmobile Use in Yellowstone National Park. Final Report. Kado, N.Y., Kuzmicky, P.A., Okamoto, R.A., Department of Environmental Toxicology, University of California, Davis, 2001
6. Personnel Air and Noise Monitoring Survey Yellowstone National Park, J. Rush Bowers, IHI Environmental, March 2004.
7. Kim, J.Y., Magari, S.R., Herrick, R.F., Smith, T.J., Christiani, D.C. Comparison of Fine Particle Measurements from a Direct-Reading Instrument and a Gravimetric Sampling Method. Journal of Occupational and Environmental Hygiene, 1:707-715, 2004
8. Klaassen, C.D., Editor, Casarett and Doull's Toxicology – The Basic Science of Poisons – 6<sup>th</sup> Edition. McGraw Hill, 2001.
9. U.S. EPA. 1992. U.S. Environmental Protection Agency. Benzene. Integrated Risk Information System (IRIS). Environmental Criteria and Assessment Office, Office of Health and Environmental Assessment, Cincinnati, OH.
10. Halmes, N.C., Roberts, S.M., Tolson, J.K., and Portier, C.J. Reevaluating cancer risk estimates for short-term exposure scenarios. Tox. Sci. 58:32-42, 2000.
11. Teuschler, L.K., Gennings, C., Hartely, W.R., Carter, H., Thiagarajah, A., Schoeny, R., Cubbison, C., The interaction effects of binary mixtures of benzene and toluene on the developing heart of medaka (*Oryzias latipes*). Chemosphere.58:1283-1291, 2005

12. Fundamentals of Industrial Hygiene, 5<sup>th</sup> Edition. B.A. Plog, P.J. Quinlan, Editors, 2002.

## **Appendix A**

## **Occupational Safety and Health Administration (OSHA)**

Health standards are promulgated under the OSHAct by the Department of Labor with technical advice from NIOSH. OSHA's limits are called Permissible Exposure Limits (PELs). OSHA's PELs are expressed as a time-weighted average and are defined as the concentration of a substance to which most workers can be exposed without adverse effect averaged over a normal 8-hour workday or a 40-hour workweek.

[www.epa.gov/ttn/atw/hlthef/hapglossaryrev.html](http://www.epa.gov/ttn/atw/hlthef/hapglossaryrev.html)

OSHA sets PELs to protect workers against the health effects of exposure to hazardous substances. PELs are regulatory limits on the amount or concentration of a substance in the air. They may also contain a skin designation. PELs are enforceable.

<http://www.osha.gov/SLTC/pel/>

## **National Institute for Occupational Safety and Health (NIOSH)**

The NIOSH recommended exposure limits (RELs) are time-weighted average (TWA) concentrations for up to a 10-hour workday during a 40-hour workweek. A short-term exposure limit (STEL) is designated by "ST" preceding the value; unless noted otherwise, the STEL is a 15-minute TWA exposure that should not be exceeded at any time during a workday. A ceiling REL is designated by "C" preceding the value; unless noted otherwise, the ceiling value should not be exceeded at any time. Any substance that NIOSH considers to be a potential occupational carcinogen is designated by the notation "Ca".

(Fundamentals of Industrial Hygiene 3<sup>rd</sup> Ed.)

## **American Conference of Governmental Industrial Hygienists (ACGIH) Threshold Limit Values**

Threshold Limit Values refer to airborne concentrations of substances, and it is believed represent conditions under which nearly all workers may be repeatedly exposed, day after day, without adverse effect. Control of the work environment is based on the assumption that for each substance there is some safe or tolerable level of exposure below which no significant adverse effect occurs. These tolerable levels are called Threshold Limit Values. The copyrighted trademark, "Threshold Limit Value" refers to limits published by the American Conference of Governmental Industrial Hygienists (ACGIH). The TLVs are reviewed and updated annually to reflect the most current information on the effects of each substance assigned a TLV.

Three categories of Threshold Limit Values are specified as follows:

**Time-Weighted Average (TLV-TWA).** The is the time-weighted average concentration for a normal 8-hour workday or 40-hour workweek, to which nearly all workers may be repeatedly exposed, day after day, without adverse effect.

**Short-Term Exposure Limit (TLV-STEL).** This is the maximal concentration to which workers can be exposed for a period of up to 15 minutes continuously without suffering from any of the following:

1. Irritation
2. Chronic or irreversible tissue change
3. Narcosis of sufficient degree to increase the likelihood of accidental injury, impair self-rescue, or materially reduce work efficiency.

A STEL is a 15-minute TWA exposure that should not be exceeded at any time during a workday, even if the 8-hour TWA is within the TLV. Exposures at the STEL should not be longer than 15 minutes and should not be repeated more than four times daily. There should be at least 60 minutes between successive exposures at the STEL.

The TLV-STEL is not a separate, independent exposure limit; it supplements the TWA limit when there are recognized acute effects from a substance that has primarily chronic effects. The STELs are recommended only when toxic effects in humans or animals have been reported from high short-term exposures.

**Ceiling (TLV-C).** This is the concentration that should not be exceeded during any part of the working exposure. To assess a TLV-C, the conventional industrial hygiene practice is to sample during a 15-minute period, except for those substances that can cause immediate irritation with exceedingly short exposures.

For some substances, irritant gases for example, only one category, the TLV-C, may be relevant. For other substances, two or three categories may be relevant, depending on their physiological action. If any one of these three TLVs is exceeded, a potential hazard from that substance is presumed to exist.

The amount by which threshold limits can be exceeded for short periods without injury to health depends on many factors, such as the nature of the contaminant, whether very high concentrations, even for a short period, produce acute poisoning, whether the effects are cumulative, the frequency with which high concentrations occur, and the duration of such periods. All factors must be considered when deciding whether a hazardous condition exists.

(Fundamentals of Industrial Hygiene 3<sup>rd</sup> Ed.)

## **ATSDR**

An MRL is an estimate of the daily human exposure to a hazardous substance that is likely to be without appreciable risk of adverse noncancer health effects over a specified duration of exposure. These substance specific estimates, which are intended to serve as screening levels, are used by ATSDR health assessors and other responders to identify contaminants and potential health effects that may be of concern at hazardous waste sites.

The toxicological profiles include an examination, summary, and interpretation of available toxicological information and epidemiologic evaluations of a hazardous substance. During the development of toxicological profiles, MRLs are derived when ATSDR determines that reliable and sufficient data exist to identify the target organ(s) of effect or the most sensitive health effect(s) for a specific duration for a given route of exposure to the substance. MRLs are based on noncancer health effects only and are not on a consideration of cancer effects. Inhalation MRLs are exposure concentrations expressed in units of parts per million (ppm) for gases and volatiles, or milligrams per cubic meter (mg/m<sup>3</sup>) for particles. Oral MRLs are expressed as daily human doses in units per kilogram per day (mg/kg/day). Radiation MRLs are expressed as external exposures in units of millisieverts.

ATSDR uses the no observed adverse effect level/uncertainty factor (NOAEL/UF) approach to derive MRLs for hazardous substances. They are set below levels that, based on current information, might cause adverse health effects in the people most sensitive to such substance induced effects. MRLs are derived for acute, intermediate, and chronic exposure durations, and for the oral and inhalation routes of exposure. MRLs are generally based on the most sensitive substance-induced end point considered to be of relevance to humans. ATSDR does not use serious health effects (such as irreparable damage to the liver or kidneys, or birth defects) as a basis for establishing MRLs. Exposure to a level above the MRL does not mean that adverse health effects will occur.

MRLs are intended to serve as a screening tool to help public health professionals decide where to look more closely. They may also be viewed as a mechanism to identify those hazardous waste sites that are not expected to cause adverse health effects. Most MRLs contain some degree of uncertainty because of the lack of precise toxicological information on the people who might be most sensitive to effects of hazardous substances. ATSDR uses a conservative approach to address these uncertainties consistent with the public health principle of prevention.

## **Standards**

### **OSHA**

Occupational Noise Exposure – 29 CFR 1926.52

Permissible Exposure Limits – 29 CFR 1910.1000 Table Z-1, Z-2

General Industry

1910 Subpart Z Toxic and hazardous substances

1910.1017 Vinyl Chloride

1910.1028 Benzene

1910.1048 Formaldehyde

1910.1051 1, 3-Butadiene

1910.1052 Methylene Chloride



## **NIOSH**

2004 NIOSH Pocket Guide to Chemical Hazards  
1998 Revised criteria – Occupational Noise Standard

## **ACGIH**

2004 Threshold Limit Values for Chemical Substances in the Work Environment  
Adopted Threshold Limit Values, pages 10-63  
2004 Threshold Limit Values for Physical Agents in the Work Environment  
Acoustic, Noise – pages 104 – 106

## **ATSDR**

December 2004 Minimal Risk Levels (MRLs)

## **Appendix B**

## ALDEHYDES, SCREENING

2539

Table 1

MW: Table 1

CAS: Table 1

RTECS: Table 1

<b>METHOD:</b> 2539, Issue 2		<b>EVALUATION:</b> PARTIAL		<b>Issue 1:</b> 15 May 1989 <b>Issue 2:</b> 15 August 1994	
<b>OSHA:</b> Table 1 <b>NIOSH:</b> Table 1 <b>ACGIH:</b> Table 1		<b>PROPERTIES:</b> Table 1			
<b>COMPOUNDS:</b> acetaldehyde; acrolein; butyraldehyde; crotonaldehyde; formaldehyde; furfural; heptanal; hexanal; isobutyraldehyde; isovaleraldehyde; propionaldehyde; valeraldehyde.					
<b>SYNONYMS:</b> Table 1					
SAMPLING			MEASUREMENT		
<b>SAMPLER:</b>	SOLID SORBENT TUBE (10% 2-(hydroxymethyl) piperidine on XAD-2, 120 mg/60 mg)		<b>TECHNIQUE:</b>	GAS CHROMATOGRAPHY, FID & GC/MS	
<b>FLOW RATE:</b>	0.01 to 0.05 L/min		<b>ANALYTE:</b>	oxazolidine prepared from aldehyde	
<b>VOLUME:</b>	5 L		<b>DESORPTION:</b>	1 mL toluene; 60 min ultrasonic	
<b>SHIPMENT:</b>	@ 25 °C or lower		<b>INJECTION VOLUME:</b>	1µL splitless; split vent time 30 sec	
<b>SAMPLE STABILITY:</b>	at least 1 week @ 25 °C		<b>TEMPERATURE-INJECTION:</b>	250 °C	
<b>FIELD BLANKS:</b>	2 to 10 field blanks per set		<b>-DETECTOR:</b>	280 °C	
<b>MEDIA BLANKS:</b>	6 per set		<b>-COLUMN:</b>	1 min @ 70 °C, 6 °C/min to 100 °C for 2 min; 30 °C/min to 260 °C	
ACCURACY			<b>CARRIER GAS:</b>	He, 0.5 mL/min; makeup flow, 29 mL/min	
<b>RANGE STUDIED:</b>	not studied		<b>COLUMN:</b>	capillary, 15 m x 0.32-mm, 1.0-µm film 6% cyanopropyl-phenyl, DB-1301 or equivalent	
<b>BIAS:</b>	not determined		<b>CALIBRATION:</b>	standard solutions of aldehydes spiked on sorbent	
<b>OVERALL PRECISION (S<sub>r</sub>):</b>	not determined		<b>RANGE AND PRECISION:</b>	not determined	
<b>ACCURACY:</b>	not determined		<b>ESTIMATED LOD:</b>	2 µg aldehyde per sample	
<b>APPLICABILITY:</b> This is a screening technique to determine the presence of aldehydes and should not be used for quantitation. Further confirmation of aldehyde identification should be performed by gas chromatography/mass spectrometry (See Table 2 for structural ion data). Methods for quantitation of some aldehydes listed in this method are available in the NIOSH Manual of Analytical Methods (See OTHER METHODS). All aldehydes tested have detected by this method in bulk field samples.					
<b>INTERFERENCES:</b> High-boiling naphtha mixtures, such as kerosene and mineral spirits may have components with retention times similar to the oxazolidines and may be interferences in the gas chromatographic analysis. A second column (DB-5, DB-WAX) may be needed to separate some of the earlier C <sub>3</sub> -C <sub>4</sub> aldehydes from excess HMP reagent.					
<b>OTHER METHODS:</b> This method incorporates sampling technology used in NIOSH methods 2501 (acrolein), 2541 (formaldehyde), 2529 (furfural), 2531 (glutaraldehyde) [1], and 2526 (valeraldehyde), and OSHA methods 68 (acetaldehyde) and 52 (acrolein/formaldehyde) [2].					

**REAGENTS:**

1. Toluene, chromatographic quality.
2. 2-(Hydroxymethyl) piperidine. Recrystallize several times from isooctane until there is one major peak (>95% of area) by GC analysis. Store in desiccator.
3. Amberlite XAD-2 (Rohm and Haas or equivalent).
4. Formaldehyde, \* 3.7% (w/v) solution in water.
5. Formaldehyde stock solution, 1 µg/µL (see APPENDIX A).
6. Acetaldehyde\*.
7. Acrolein\*.
8. Propionaldehyde\*.
9. Butyraldehyde\*.
10. Isobutyraldehyde\*.
11. Crotonaldehyde\*.
12. Valeraldehyde\*.
13. Isovaleraldehyde\*.
14. Hexanal\*.
15. Heptanal\*.
16. Furfural\*.
17. Sulfuric acid, 0.02 N.
18. Sodium hydroxide, 0.01 N.
19. Sodium sulfite, 1.13 M.
20. Water, deionized, then distilled.
21. Hydrogen, prepurified.
22. Air, filtered, compressed.
23. Helium, purified.

\* See SPECIAL PRECAUTIONS

**EQUIPMENT:**

1. Sampler: glass tube, 10 cm long, 6-mm OD, 4-mm ID; flame-sealed ends and plastic caps, containing two sections of 40/60 mesh, 2-(hydroxymethyl) piperidine-coated XAD-2 (front = 120 mg; back = 60 mg; see APPENDIX A) retained and separated by small plugs of silanized glass wool. Pressure drop across the tube at 0.10 L/min airflow must be less than 760 kPa (5.7 mm Hg). Tubes are commercially available (Supelco, Inc. ORBO-23 or equivalent).
2. Personal sampling pump, 0.01 to 0.05 L/min, with flexible connecting tubing.
3. Gas chromatograph, flame ionization detector (FID), integrator and column (page 2539-1). GC/MS system for confirmation.
4. Ultrasonic bath.
5. Vials, glass, 1-mL, with PTFE-lined crimp caps.
6. Flasks, volumetric, 10-mL.
7. Pipets, volumetric, 1-mL with pipet bulb.
8. Syringes, 10-µL (readable to 0.1-µL), 25-, and 50-µL.
9. File.
10. Beakers, 50-mL.
11. pH meter.
12. Magnetic stirrer.
13. Burets, 50-mL.
14. Flasks, round-bottomed, 100-mL.
15. Soxhlet extraction apparatus.
16. Vacuum oven.
17. Distillation apparatus.

---

**SPECIAL PRECAUTIONS:** Aldehydes can irritate the mucous membranes and act on the central nervous system [3]. Certain aldehydes are also suspect carcinogens. Work with these compounds only in a well-ventilated hood.

---

**SAMPLING:**

1. Calibrate each personal sampling pump with a representative sampler in line.
2. Break ends of the sampler immediately before sampling. Attach sampler to personal sampling pump with flexible tubing.
3. For general screening, sample at 0.01 to 0.05 L/min for a maximum sample volume of 5 L.

NOTE: Aldehydes react with the 2-(hydroxymethyl)piperidine to form an oxazolidine derivative in the sorbent bed during sampling. Sampling rate is limited by the speed of this reaction. Owing to the lower reactivities of some aldehydes, sampling even at 0.02 L/min may cause breakthrough because of incomplete reaction.

**SAMPLE PREPARATION:**

ALDEHYDES, SCREENING: METHOD 2539, Issue 2, dated 15 August 1994 - Page 3 of 10

4. Score each sampler with a file in front of the first sorbent section.
5. Break sampler at score line. Remove and place front glass wool plug and front sorbent section in a vial. Transfer back section with remaining glass wool plugs to a second vial.
6. Add 1.0 mL toluene to each vial. Crimp cap tightly onto each vial.
7. Agitate vials in an ultrasonic bath for 60 min.

**CALIBRATION AND QUALITY CONTROL:**

8. Prepare qualitative oxazolidine standard samples.
  - a. Prepare aldehyde standard stock solutions.

NOTE: Aldehydes can oxidize to other compounds on exposure to air. This will introduce bias into the method, so use of freshly-opened bottles of aldehydes is recommended.

    - (1) Inject an aliquot of form aldehyde stock solution directly onto the sorbent.
    - (2) Take special care with acetaldehyde because of its volatility. To prepare acetaldehyde standard solutions, weigh a 10-mL capped volumetric flask containing about 5 mL toluene. With a cooled pipette, transfer about 1 mL of acetaldehyde into the weighed flask, recap and reweigh. Dilute to the mark.
    - (3) For the other aldehydes, add measured aliquots (ca. 12  $\mu$ L) of each to toluene in 10-mL volumetric flasks and dilute to the mark. From the density of each aldehyde, determine the amount of each aldehyde present in each solution (ca. 1  $\mu$ g/ $\mu$ L).
  - b. Inject 10  $\mu$ L of the standard aldehyde solutions separately onto blank tubes from the same lot as the field samples.
  - c. Analyze (steps 4 through 7 and 10 through 12) along with blanks for qualitative identification of derivative peaks by retention times.
9. Determine limit of detection (LOD) for individual aldehydes by GC/FID with standards covering the range 0.5 to 10  $\mu$ g per sample. Do this once, when first setting up the method to determine approximate sensitivities for the various aldehyde derivatives. Subsequently, analyze only low-level formaldehyde standard samples with each set of samples as an internal check that the analytical system is working.
  - a. Weigh 120-mg portions of unused sorbent from media blanks into vials. Keep at least three 120-mg portions of this sorbent for determination of the background levels of each aldehyde.
  - b. Add 0.5- to 10- $\mu$ L aliquots of the individual aldehyde standard solutions to obtain standard samples in the range 0.5 to 10  $\mu$ g per 120 mg portion of sorbent. Cap vials and allow to stand overnight at room temperature.
  - c. Desorb the standard samples of aldehydes (steps 6 and 7) and analyze (steps 10 through 12) along with blanks.
  - d. Determine lowest spike to be detected (peak area greater than three times the background or lowest standard observable) to estimate LOD for each aldehyde.

NOTE: Because the working standards are prepared on media blanks, no additional blank correction or desorption efficiency correction is necessary.

**MEASUREMENT:**

10. Set gas chromatograph to manufacturer's recommendations and to conditions given on page 2539-1. Inject 1- $\mu$ L sample aliquot.

NOTE: If the amount of oxazolidine in the aliquot exceeds the capacity of the column, dilute the sample with toluene.
11. Compare retention times of unknown peaks in samples to the retention times for the oxazolidines as determined by the qualitative standard samples. (See Appendix B for sample

chromatogram).

- a. Analyze samples with GC retention times matching any oxazolidine by GC/MS using the same GC columns and conditions if possible. Alternate columns such as a DB-WAX (formaldehyde, acetaldehyde, propanal) or DB-1 (remaining aldehydes) may also be used for GC/MS confirmation depending on which aldehyde is suspected.
- b. Determine the presence of oxazolidines by monitoring for specific ions known to be present in the derivative spectra. See Table 2 for characteristic ion table and Appendix C for reference mass spectra. Retention times by GC/MS must also match authentic oxazolidine standards.

NOTE 1: This method may also sample aldehydes other than those listed. The presence of these other aldehydes can be confirmed by examination of the mass spectral data and observation of peaks at  $m/e$  126 and at the molecular ion minus one mass unit. The molecular ion for a particular aldehyde is equal to the molecular weight of the original aldehyde plus 97. Fragmentation patterns are also important for the identification of the oxazolidines.

NOTE 2: The absence of some  $C_3$ - $C_5$  aldehydes, such as propionaldehyde, isobutyraldehyde and crotonaldehyde, does not necessarily mean that these compounds are not present in the air sampled. These compounds are not efficiently trapped by the sorbent, and will readily breakthrough the sampler sorbent beds.

NOTE 3: Higher molecular weight aldehydes, such as isovaleraldehyde, hexanal and heptanal, probably will be more efficiently collected on the sorbent owing to their lower vapor pressure. Thus, absence of these compounds in sample results may be indicative of the absence of these compounds in the environment sampled.

12. Report the presence of a particular aldehyde if:
  - a. There is a detectable peak by GC-FID at the correct retention time for that aldehyde derivative.
  - b. The correct mass spectrum for the derivative is obtained by GC/MS at the proper retention time.

**REFERENCES:**

- [1] NIOSH Manual of Analytical Methods, 3rd ed., P.M. Eller, Ed., DHHS (NIOSH) Publication No. 84-100 (1984).
- [2] Occupational Safety and Health Administration, "OSHA Analytical Method Manual," American Conference of Governmental Industrial Hygienists, Cincinnati, OH (1985).
- [3] Kennedy, E. R., P. F. O'Connor, Y. T. Gagnon. Determination of Acrolein in Air as an Oxazolidine Derivative by Gas Chromatography. *Anal. Chem.*, **56**, 2120-2123 (1984).
- [4] Kennedy, E. R., Y. T. Gagnon, J. R. Okenfuss, A. W. Teass. The Determination in Air of Selected Low-molecular Weight Aldehydes as Their Oxazolidines by Capillary Gas Chromatography. *Appl. Ind. Hyg.*, **3**, 274-279 (1988).

**METHOD WRITTEN (REVISED) BY:**

Ardith A. Grote and Eugene R. Kennedy, Ph.D., NIOSH/DPSE.

**TABLE 1. GENERAL INFORMATION**

Compound Limits (ppm)	VP (mm Hg)	d(g/mL)	Exposure
--------------------------	------------	---------	----------

NIOSH Manual of Analytical Methods (NMAM), Fourth Edition

ALDEHYDES, SCREENING: METHOD 2539, Issue 2, dated 15 August 1994 - Page 5 of 10

(Synonyms)	Formula	MW	@ 20 °C	BP(°C)	OSHA	NIOSH	ACGH	(@ 20 °C)
Formaldehyde (formic aldehyde; formalin; CAS #50-00-0 RTECS LP8925000	CH <sub>2</sub> O	30.03	-	-19.5	3; C 5; P 10/30 min	Carc.*; 0.016 C 0.1 Group I Pesticide	C 0.3 Suspected Carcinogen	20 (-88°C)
Acetaldehyde (acetic aldehyde; ethyl aldehyde; CAS #75-07-0 RTECS AB1925000	C <sub>2</sub> H <sub>4</sub> O	44.05	0.788 (@ 16°C)	21	200	Carc.* 18 ppm LOQ	100 150 STEL	740
Propionaldehyde (propanal; CAS # 123-38-6) RTECS UE0350000	C <sub>3</sub> H <sub>6</sub> O	58.08	0.807	49	-	-	-	258
Acrolein (2-propanal; allyl aldehyde; CAS #107-02-8) RTECS AS1050000	C <sub>3</sub> H <sub>4</sub> O	56.06	0.839	52.5	0.1	0.1 0.3 STEL Group I Pesticide	0.1 0.3 STEL	210
Butyraldehyde (butanal; CAS # 123-72-8) RTECS ES2275000	C <sub>4</sub> H <sub>8</sub> O	72.10	0.802	75	-	-	-	92
Isobutyraldehyde (2-methylpropanal dimethylacetaldehyde; CAS #76-84-2) RTECS NQ4025000	C <sub>4</sub> H <sub>8</sub> O	72.10	0.794	64	-	-	-	170
Crotonaldehyde (2-butenal; β-methyl acrolein; CAS # 123-73-9) RTECS GP9625000	C <sub>4</sub> H <sub>6</sub> O	70.09	0.853	104	2	2	2	30
n-Valeraldehyde (pentanal; CAS # 110-62-3) RTECS YV3600000	C <sub>5</sub> H <sub>10</sub> O	86.13	0.810	102	no standard	50	50	50
Isovaleraldehyde (3-methylbutanal; isopentanal; CAS # 590-86-3) RTECS ES3450000	C <sub>5</sub> H <sub>10</sub> O	86.13	0.785	92	-	-	-	50
Hexanal (caproaldehyde; CAS # 66-25-1) RTECS MN7175000	C <sub>6</sub> H <sub>12</sub> O	100.16	0.834	131	-	-	-	10
Heptanal (enanthal; CAS #111-71-7) RTECS MI6900000	C <sub>7</sub> H <sub>14</sub> O	114.18	0.809 (@ 30°C)	153	-	-	-	3
Furfural (2-furan-carboxaldehyde; CAS # 68-01-1) RTECS LT7000000	C <sub>5</sub> H <sub>4</sub> O <sub>2</sub>	96.08	1.16 (@ 25°C)	162	5 (skin)	-	2 (skin)	

\*- Carcinogen

TABLE 2 MASS SPECTRAL DATA FOR ALDEHYDE DERIVATIVES OF 2-(HYDROXYMETHYL)PIPERIDINE (HMP)

Aldehyde	Formula	HMP DERIVATIVE	
		Base Peak m/z	Other Characteristic Ions m/z
Formaldehyde	C <sub>1</sub> H <sub>2</sub> NO	97	126, 127*
Acetaldehyde	C <sub>3</sub> H <sub>4</sub> NO	126	140, 141*
Propionaldehyde	C <sub>3</sub> H <sub>6</sub> NO	126	154, 155*
Acrolein	C <sub>3</sub> H <sub>4</sub> NO	126	152, 153*
Butyraldehyde	C <sub>4</sub> H <sub>8</sub> NO	126	168, 169*
Isobutyraldehyde	C <sub>4</sub> H <sub>8</sub> NO	126	168, 169*
Crotonaldehyde	C <sub>4</sub> H <sub>6</sub> NO	126	166, 167*
Valeraldehyde	C <sub>5</sub> H <sub>10</sub> NO	126	182, 183*
Isovaleraldehyde	C <sub>5</sub> H <sub>10</sub> NO	126	182, 183*
Hexanal	C <sub>6</sub> H <sub>12</sub> NO	126	196, 197*
Heptanal	C <sub>7</sub> H <sub>14</sub> NO	126	210, 211*
Furfural	C <sub>5</sub> H <sub>6</sub> NO <sub>2</sub>	192	95, 163, 193*

\* indicates molecular ion.

## APPENDIX A:

SORBENT PREPARATION (optional if commercially prepared tubes are used):

Extract Amberlite XADS-2 for 4 h in Soxhlet with 50/50 (v/v) acetone/methylene chloride. Replace with fresh solvent and repeat. Vacuum dry overnight. Add 1 g purified 2-(hydroxymethyl)piperidine in 50 mL toluene for each 9 g extracted XAD-2 sorbent. Allow this mixture to stand 1 h with occasional swirling. Remove the solvent by rotary evaporation at 37 °C and dry at 130 kPa (1 mm Hg) at ambient temperature for ca. 1 h. To determine the amount of background for each batch, extract several 120-mg portions of the coated sorbent with toluene and analyze (steps 6 through 12). No blank peak is expected for any aldehydes other than formaldehyde and possibly acetaldehyde.

SYNTHESIS OF ALDEHYDE OXAZOLIDINES:

Place a solution of purified 2-hydroxymethylpiperidine (0.57 g, 5 mmol) in 10 mL of toluene in a 50-mL round-bottomed flask. Use several 20 mL portions of toluene to rinse residual 1-(hydroxymethyl)piperidine from the container used for weighing. Add anhydrous magnesium sulfate (2.5 g) to the round-bottomed flask to dry the aldehyde solution as it is added and to remove the water which forms during the reaction. Add a solution of 10 mole of aldehyde in 10 mL of toluene to the 2-hydroxymethylpiperidine solution dropwise with stirring over 1 h. Stir the solution overnight, then filter to remove the magnesium sulfate. Remove the toluene and excess aldehyde from the solution at reduced pressure by rotary evaporation.

PREPARATION AND STANDARDIZATION OF FORMALDEHYDE STOCK SOLUTION (ca. 1 mg/mL):

Dilute 2.7 mL 37% aqueous formalin solution to 1 L with distilled, deionized water. This solution is stable for at least three months. Standardize by placing 5.0 mL of freshly prepared 1.13 M sodium sulfite solution in a 50-mL beaker and stir magnetically. Adjust pH to between 8.5 and 10 with base or acid. Record the pH. Add 10.0 mL stock formaldehyde solution. The pH should be greater than 11. Titrate the solution back to its original pH with 0.02 N sulfuric acid (1 mL acid = 0.600 mg HCHO; about 17 mL acid needed). If the endpoint pH is overrun, back titrate to the endpoint with 0.01 N sodium hydroxide. Calculate the concentration, C<sub>s</sub> (mg/mL), of the formaldehyde stock solution:

$$C_s = \frac{30.0 \times (N_a \cdot V_a - N_b \cdot V_b)}{V_s}$$

where: 30.0 = 30.0 g/equivalent of formaldehyde  
N<sub>a</sub> = normality of sulfuric acid



ALDEHYDES, SCREENING: METHOD 2539, Issue 2, dated 15 August 1994 - Page 7 of 10

$V_a$  = volume of sulfuric acid (mL) used for titration

$N_b$  = normality of NaOH

$V_b$  = volume of NaOH (mL) used for back titration

$V_s$  = volume of formaldehyde stock solution (10.0 mL).

ALDEHYDES, SCREENING: METHOD 2539, Issue 2, dated 15 August 1994 - Page 8 of 10  
APPENDIX B: Sample chromatogram of aldehyde oxazolidines on DB-1301 column using conditions listed on page 2539-1.

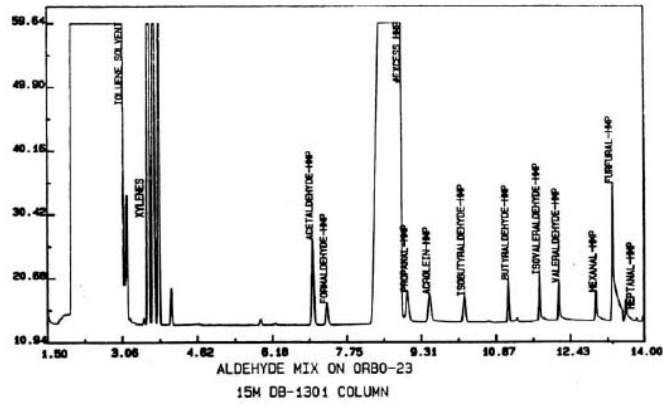

ALDEHYDES, SCREENING: METHOD 2539, Issue 2, dated 15 August 1994 - Page 9 of 10  
 APPENDIX C: Reference mass spectra of oxazolidines of aldehydes individually spiked onto ORBO-23 tubes. GC/MS conditions: HP 5890 gas chromatograph interfaced (direct) to HP 5970 mass-selective detector (70eV); 30-m DB-1 column, 0.25-mm I.D., 1.0- $\mu$ m film; 70 °C for 1 min, 15 °C/min to 300 °C; interface temperature, 280 °C; injector, 250 °C, 1  $\mu$ L splitless injection; scan 20-400 amu.

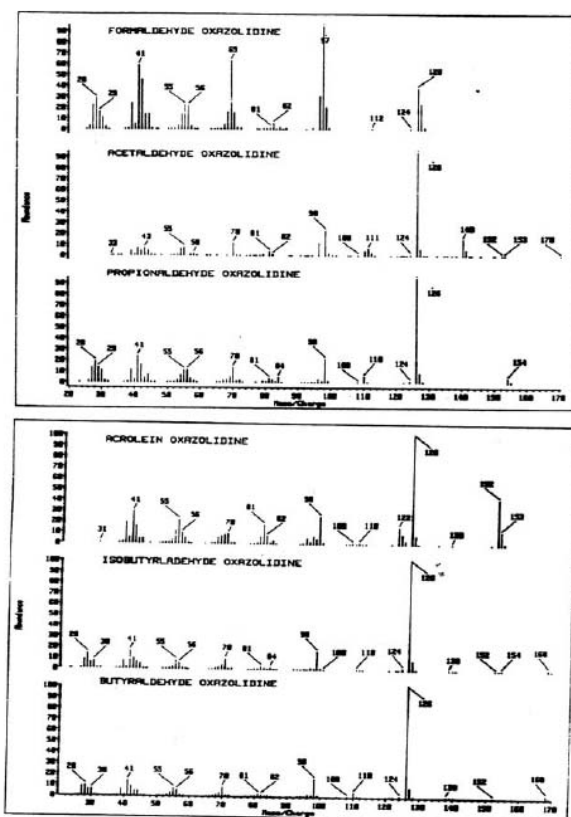

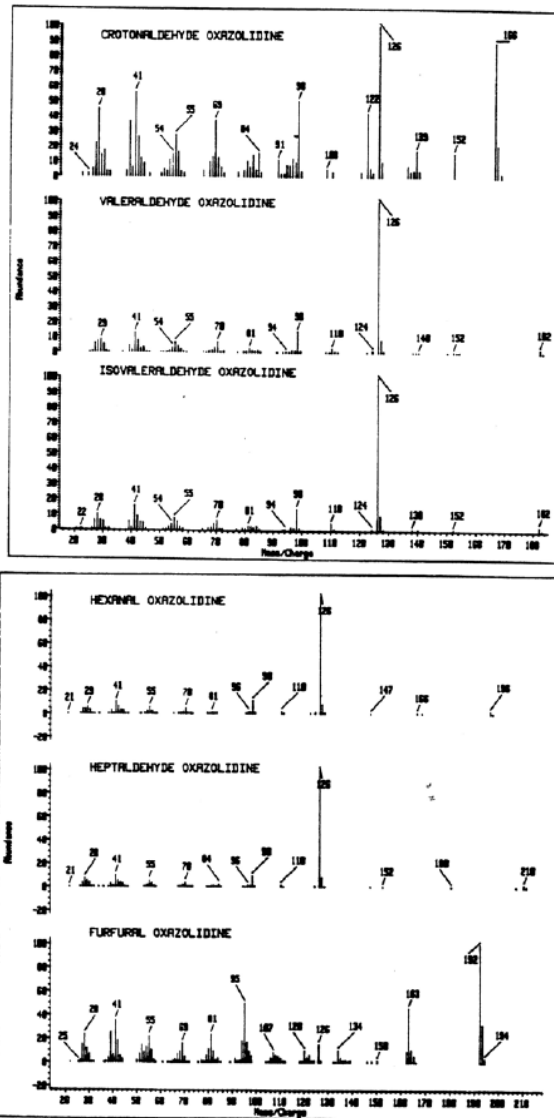

HYDROCARBONS, AROMATIC

1501

FORMULA: Table 1

MW: Table 1

CAS: Table 1

RTECS: Table 1

METHOD: 1501, Issue 3		EVALUATION: Full		Issue 1: 15 August 1990 Issue 3: 15 March 2003	
OSHA: Table 2 NIOSH: Table 2 ACGIH: Table 2		PROPERTIES: Table 1			
SYNONYMS: <u>Group A:</u> benzene    toluene    ethylbenzene <i>p</i> -xylene <i>m</i> -xylene <i>p</i> -xylene (Synonyms in Table 1) <u>Group B:</u> cumene <i>p</i> -tert-butyltoluene $\alpha$ -methylstyrene $\beta$ -methylstyrene    styrene					
SAMPLING		MEASUREMENT			
SAMPLER:	SOLID SORBENT TUBE (coconut shell charcoal, 100 mg/50 mg)	TECHNIQUE:	GAS CHROMATOGRAPHY, FID		
FLOW RATE:	Table 3	ANALYTE:	Hydrocarbons listed above		
VOL-MIN:	Table 3	DESORPTION:	1 mL CS <sub>2</sub> , stand 30 min with agitation		
-MAX:	Table 3	INJECTION VOLUME:	1 $\mu$ L ( <u>Group A:</u> split 5:1; <u>Group B:</u> split 1:1)		
SHIPMENT:	Routine	TEMPERATURE			
SAMPLE STABILITY:	30 days @ 5°C	-INJECTION:	250 °C		
BLANKS:	10% of samples	-DETECTOR:	300 °C		
		-COLUMN:	<u>Group A:</u> 40 °C (10 min) to 230°C (10 °C/min) <u>Group B:</u> 35 °C (8 min) to 225°C (10 °C/min)		
		CARRIER GAS:	He @ 2.6 mL/min		
ACCURACY		COLUMN:	Capillary, fused silica <u>Group A:</u> 30m x 0.32-mm ID; 1- $\mu$ m film 100% PEG or equivalent <u>Group B:</u> 30m x 0.53-mm ID; 3- $\mu$ m film crossbonded@35% diphenyl 65% dimethyl polysiloxane or equivalent		
RANGE STUDIED:	Table 3	CALIBRATION:	Solutions of analytes in CS <sub>2</sub>		
BIAS:	Table 3	RANGE:	Table 4		
OVERALL PRECISION ( $\bar{S}_r$ ):	Table 3	ESTIMATED LOD:	Table 4		
ACCURACY:	Table 3	PRECISION ( $\bar{S}_s$ ):	Table 4		

**APPLICABILITY:** This method is for peak, ceiling, and TWA determinations of aromatic hydrocarbons. Interactions between analytes may reduce breakthrough volumes and affect desorption efficiencies. Naphthalene, originally validated in S292 [4], failed to meet acceptable desorption efficiency recovery and storage stability criteria at the levels evaluated in this study. However, the application of this method to naphthalene levels at or near the REL/PEL continues to meet acceptable recovery criteria. Styrene failed to meet acceptable recovery criteria at the two lowest levels evaluated in this study (highest level to meet the criteria was 181  $\mu$ g/sample).

**INTERFERENCES:** Under conditions of high humidity, the breakthrough volumes may be reduced. Other volatile organic compounds such as alcohols, ketones, ethers, and halogenated hydrocarbons are potential analytical interferences.

**OTHER METHODS:** This method updates NMAM 1501 issued on August 15, 1994 [1] which was based upon P&CAM 127 (benzene, styrene, toluene, and xylene) [2]; S22 (*p*-tert-butyltoluene) [3]; S23 (cumene) [3]; S29 (ethylbenzene) [3]; S26 ( $\alpha$ -methylstyrene) [3]; S30 (styrene); S311 (benzene) [4]; S343 (toluene) [4]; and S318 (xylenes) [4].

**REAGENTS:**

1. Carbon disulfide\*, low benzene, chromatographic quality.
2. Analytes, reagent grade.
3. Helium, prepurified and filtered.
4. Hydrogen, prepurified and filtered.
5. Air, prepurified and filtered.

\* See SPECIAL PRECAUTIONS

**EQUIPMENT:**

1. Sampler: glass tube, 7 cm long, 6-mm OD, 4-mm ID, flame-sealed ends, containing two sections of activated coconut shell charcoal (front = 100 mg, back = 50 mg) separated by a 2-mm urethane foam plug. A silylated glass wool plug precedes the front section and a 3-mm urethane foam plug follows the back section. Tubes are commercially available.
2. Personal sampling pump, 0.01 to 1.0 L/min (Table 3), with flexible connecting tubing.
3. Gas chromatograph, FID, integrator, and columns (page 1501-1).
4. Autosampler vials, glass, 1.8 mL, with PTFE-lined caps.
5. Pipets, 1-mL, and pipet bulb.
6. Syringes, 10- $\mu$ L, 25- $\mu$ L, and 250- $\mu$ L.
7. Volumetric flasks, 10-mL.

**SPECIAL PRECAUTIONS:** Carbon disulfide is toxic and extremely flammable (flash point =  $-30^{\circ}\text{C}$ ), benzene is a suspect carcinogen. Prepare standards and samples in a well ventilated hood.

**SAMPLING:**

1. Calibrate each personal sampling pump with a representative sampler in line.
2. Break the ends of the sampler immediately before sampling. Attach sampler to personal sampling pump with flexible tubing.
3. Sample at an accurately known flow rate between 0.01 and 0.2 L/min for a total sample size as shown in Table 3.
4. Cap the samplers with plastic (not rubber) caps and pack securely for shipment.

**SAMPLE PREPARATION:**

5. Place the front and back sorbent sections of the sampler tube in separate vials. Include the glass wool plug in the vial along with the front sorbent section.
6. Add 1.0 mL eluent to each vial. Attach crimp cap to each vial immediately.
7. Allow to stand at least 30 min with occasional agitation.

**CALIBRATION AND QUALITY CONTROL:**

8. Calibrate daily with at least six working standards from below the LOD to 10 times the LOQ. If necessary, additional standards may be added to extend the calibration curve.
  - a. Add known amounts of analytes to carbon disulfide solvent in 10-mL volumetric flasks and dilute to the mark. Prepare additional standards by serial dilution in 10-mL volumetric flasks.
  - b. Analyze together with samples and blanks (steps 11 through 12).
  - c. Prepare calibration graph (peak area of analyte vs.  $\mu\text{g}$  analyte per sample).

9. Determine desorption efficiency (DE) at least once for each batch of charcoal used for sampling in the calibration range (step 8).
  - a. Prepare three tubes at each of five levels plus three media blanks.
  - b. Inject a known amount of DE stock solution (5 to 25 µL) directly onto front sorbent section of each charcoal tube with a microliter syringe.
  - c. Allow the tubes to air equilibrate for several minutes, then cap the ends of each tube and allow to stand overnight.
  - d. Desorb (steps 5 through 7) and analyze together with standards and blanks (steps 11 and 12).
  - e. Prepare a graph of DE vs. µg analyte recovered.
10. Analyze a minimum of three quality control blind spikes and three analyst spikes to insure that the calibration graph and DE graph are in control.

**MEASUREMENT:**

11. Set gas chromatograph according to manufacturer's recommendations and to conditions given on page 1501-1. Inject a 1-µL sample aliquot manually using the solvent flush technique or with an autosampler. Note: If peak area is above the linear range of the working standards, dilute with solvent, reanalyze, and apply the appropriate dilution factor in the calculations.

Analyte	Approximate Retention Time (min)
benzene <sup>a</sup>	3.52
toluene <sup>a</sup>	6.13
ethylbenzene <sup>a</sup>	10.65
<i>o</i> -xylene <sup>a</sup>	12.92
<i>m</i> -xylene <sup>a</sup>	11.33
<i>p</i> -xylene <sup>a</sup>	11.04
cumene <sup>b</sup>	18.61
<i>p</i> -tert-butyltoluene <sup>b</sup>	21.45
α-methylstyrene <sup>b</sup>	19.99
β-methylstyrene <sup>b</sup>	20.82
styrene <sup>b</sup>	18.33

<sup>a</sup> Separation achieved using a 30-m Stabilwax fused silica capillary column.

<sup>b</sup> Separation achieved using a 30-m Rtx-35 fused silica capillary column.

12. Measure peak areas.

**CALCULATIONS:**

13. Determine the mass, µg (corrected for DE) of analyte found in the sample front ( $W_f$ ) and back ( $W_b$ ) sorbent sections, and in the average media blank front ( $B_f$ ) and back ( $B_b$ ) sorbent sections. NOTE: If  $W_b > W_f/10$ , report breakthrough and possible sample loss.
14. Calculate concentration,  $C$ , of analyte in the air volume sampled,  $V$  (L):

$$C = \frac{(W_f + W_b - B_f - B_b)}{V}, \text{mg} / \text{m}^3$$

NOTE: µg/L = mg/m<sup>3</sup>

**EVALUATION OF METHOD:**

The desorption efficiency, at levels ranging from 5 times the LOQ to 0.1x the REL, was determined for each analyte by spiking known amounts (in CS<sub>2</sub>) on coconut shell charcoal tubes. Both groups of analytes (A and B) were spiked together on the charcoal sorbent tubes. All analytes, with the exception of styrene and naphthalene, exhibited acceptable desorption efficiency recovery results at all five levels evaluated. Styrene failed to meet the 75% recovery criteria at the 18.1 µg and 90.6 µg levels. Naphthalene failed to meet the 75% criteria at all levels evaluated ranging from 48.8 µg to 976.0 µg.

Each analyte, at a level approximately 0.05x REL/PEL, was evaluated for its storage stability @ 5°C after 7, 14, and 30 days. All analytes, with the exception of naphthalene, had acceptable recoveries after 30 days storage.

**REFERENCES:**

- [1] NIOSH [1984]. Hydrocarbons, Aromatic: Method 1501. In: Eller PM, ed. NIOSH Manual of Analytical Methods. 4th rev. ed. Cincinnati, OH: U.S. Department of Health and Human Services, Public Health Service, Centers for Disease Control, National Institute for Occupational Safety and Health, DHHS (NIOSH) Publication No. 94-113.
- [2] NIOSH [1977]. NIOSH Manual of Analytical Methods, 2nd. ed., V. 1, P&CAM 127, U.S. Department of Health, Education, and Welfare, Publ. (NIOSH) 77-157-A.
- [3] Ibid, V. 2, S22, S23, S25, S26, S29, S30, U.S. Department of Health, Education, and Welfare, Publ. (NIOSH) 77-157-B (1977).
- [4] Ibid, V. 3, S292, S311, S318, S343, U.S. Department of Health, Education, and Welfare, Publ. (NIOSH) 77-157-C (1977).
- [5] NIOSH [1977]. Documentation of the NIOSH Validation Tests, S22, S23, S25, S26, S29, S30, S292, S311, S318, S343, U.S. Department of Health, Education, and Welfare; Publ. (NIOSH) 77-185.

**METHOD WRITTEN BY:**

Stephanie M. Pendergrass, NIOSH/DART



TABLE 1. SYNONYMS, FORMULA, MOLECULAR WEIGHT, PROPERTIES

Name/Synonyms	Empirical Formula	Molecular Weight	Boiling Point (°C)	Vapor Pressure @ 25 °C (mm Hg)	(kPa)	Density @ 20 °C (g/mL)
benzene CAS #71-43-2 RTECS CY1400000	C <sub>6</sub> H <sub>6</sub>	78.11	80.1	95.2	12.7	0.879
p-tert-butyltoluene CAS #98-51-1 RTECS XS8400000 1-tert-butyl-4-methylbenzene	C <sub>11</sub> H <sub>16</sub>	148.25	192.8	0.7	0.09	0.861
cumene CAS #98-82-8 RTECS GR8575000 isopropylbenzene	C <sub>9</sub> H <sub>12</sub>	120.20	152.4	4.7	0.63	0.862
ethylbenzene CAS #100-41-4 RTECS DA0700000	C <sub>8</sub> H <sub>10</sub>	106.17	136.2	9.6	1.28	0.867
α-methylstyrene CAS #98-83-9 RTECS WL5075300 isopropenylbenzene (1-methylethenyl)-benzene	C <sub>9</sub> H <sub>10</sub>	118.18	165.4	2.5	0.33	0.909
β-methylstyrene CAS #873-66-5 RTECS DA8400500	C <sub>9</sub> H <sub>10</sub>	118.18	175.0	—	—	0.911
toluene CAS #108-88-3 RTECS XS5250000 methylbenzene	C <sub>7</sub> H <sub>8</sub>	92.14	110.6	28.4	3.79	0.867
xylene <sup>f</sup> CAS #1330-20-7 RTECS ZE2100000 dimethylbenzene (p-xylene)	C <sub>8</sub> H <sub>10</sub> (ortho) (meta) (para)	106.17	144.4 139.1 138.4	6.7 8.4 8.8	0.89 1.12 1.18	0.880 0.864 0.861
styrene CAS #100-42-5 RTECS WL3675000 vinylbenzene	C <sub>8</sub> H <sub>8</sub>	104.15	145.2	6.1	0.81	0.906

**TABLE 2. PERMISSIBLE EXPOSURE LIMITS, PPM**

Substance	OSHA TWA	NIOSH			ACGIH		mg/m <sup>3</sup> per ppm
		TWA	C	STEL	TLV	STEL	
benzene	1	0.1 <sup>a</sup>	1		10 <sup>b</sup>		3.19
<i>p</i> - <i>tert</i> -butyltoluene	10	10		20	1		6.06
cumene	50 (skin)	50 (skin)			50 (skin)		4.91
ethylbenzene	100	100		125	100	125	4.34
$\alpha$ -methylstyrene	100	50		100	50	100	4.83
$\beta$ -methylstyrene	100	50		100	50	100	4.83
toluene	200	100		150	50 (skin)		3.77
<i>o</i> -xylene	100	100 <sup>c</sup>		150	100	150	4.34
<i>m</i> -xylene	100	100			100	150	4.34
<i>p</i> -xylene	100	100			100	150	4.34
styrene	100	50		100	50	100 (skin)	4.26

<sup>a</sup> Potential carcinogen

<sup>b</sup> Suspect carcinogen

<sup>c</sup> Group I Pesticide

**TABLE 3. SAMPLING FLOWRATE<sup>a</sup>, VOLUME, CAPACITY, RANGE, OVERALL BIAS AND PRECISION**

Substance	Sampling		Breakthrough		Range at VOL-MIN (mg/m <sup>3</sup> )	Overall		Accuracy ( $\pm$ %)
	Flowrate (L/min)	Volume <sup>b</sup> (L) MIN MAX	Volume @ Concentration (L) (mg/m <sup>3</sup> )	Concentration (mg/m <sup>3</sup> )		Bias (%)	Precision ( $\bar{S}_r$ )	
benzene	$\leq 0.20$	5 30	>45	149	42 - 165	-0.4	0.059	11.4
<i>p</i> - <i>tert</i> -butyltoluene	$\leq 0.20$	1 29	44	112	29 - 119	-10.3	0.071 <sup>c</sup>	20.7
cumene	$\leq 0.20$	1 30	>45	480	120 - 480	5.6	0.059	15.2
ethylbenzene	$\leq 0.20$	1 24	35	917	222 - 884	-7.6	0.089 <sup>c</sup>	17.1
$\alpha$ -methylstyrene	$\leq 0.20$	1 30	>45	940	236 - 943	-7.6	0.061 <sup>c</sup>	16.9
$\beta$ -methylstyrene	$\leq 0.20$	1 30	>45	940	236 - 943	-7.6	0.061	16.9
toluene	$\leq 0.20$	1 8	12	2294	548 - 2190	1.6	0.052	10.9
xylene ( <i>o</i> -, <i>m</i> -, <i>p</i> -)	$\leq 0.20$	2 23	35	870	218 - 870	-1.2	0.060	12.2
styrene	$\leq 1.00$	1 14	21	1710	426 - 1710	-7.9	0.058 <sup>c</sup>	16.7

<sup>a</sup> Minimum recommended flow is 0.01 L/min.

<sup>b</sup>  $V_{min}$  = minimum sample volume @ OSHA TWA;

$V_{max}$  = maximum sample volume @ OSHA TWA

<sup>c</sup> Corrected value, calculated from data in Reference 5.

TABLE 4. MEASUREMENT RANGE AND PRECISION<sup>a</sup>

Substance	LOD ( $\mu\text{g}/\text{sample}$ )	Measurement	
		Range (mg)	Precision ( $\hat{S}_r$ )
benzene	0.5	0.004-0.35	0.013
<i>p</i> -tert-butyltoluene	1.1	0.013-1.09	0.017 <sup>a</sup>
cumene	0.6	0.039-3.46	0.017
ethylbenzene	0.5	0.045-8.67	0.015
$\alpha$ -methylstyrene	0.6	0.036-3.57	0.014
$\beta$ -methylstyrene	0.6	0.036-0.728	0.014
toluene	0.7	0.024-4.51	0.022
<i>o</i> -xylene	0.8	0.044-10.4	0.014
<i>m</i> -xylene	0.8	0.043-0.864	0.013
<i>p</i> -xylene	0.7	0.043-0.861	0.015
styrene	0.4	0.181-8.49	0.014

<sup>a</sup> Corrected value, calculated from data in [5].

NITRIC OXIDE and NITROGEN DIOXIDE

6014

NO MW: 30.01 CAS: 10102-43-9 RTECS: QX0525000  
 NO<sub>2</sub> 46.01 10102-44-0 QW9800000

METHOD: 6014, Issue 1 EVALUATION: FULL Issue 1: 15 August 1994

OSHA : 25 ppm NO; C 1 ppm NO<sub>2</sub>  
 NIOSH: 25 ppm NO; 1 ppm STEL NO<sub>2</sub>  
 ACGIH: 25 ppm NO; 3 ppm TWA, 5 ppm STEL NO<sub>2</sub>  
 (1 ppm NO = 1.227 mg/m<sup>3</sup> @ NTP)  
 (1 ppm NO<sub>2</sub> = 1.882 mg/m<sup>3</sup> @ NTP)

PROPERTIES: NO: gas; BP -151.7 °C; vapor density (air=1) 1.0  
 NO<sub>2</sub>: gas; MP -11.2 °C; BP 21 °C; vapor density (air=1) 2.83

SYNONYMS: NO: nitrogen monoxide  
 NO<sub>2</sub>: nitrogen peroxide; nitrogen tetroxide

SAMPLING		MEASUREMENT	
<b>SAMPLER:</b>	SORBENT TUBES (oxidizer + 2 triethanolamine-treated molecular sieve)	<b>TECHNIQUE:</b>	VISIBLE ABSORPTION SPECTROPHOTOMETRY
<b>FLOW RATE:</b>	NO: 0.025 L/min NO <sub>2</sub> : 0.025 - 0.2 L/min	<b>ANALYTE:</b>	nitrite ion, NO <sub>2</sub> <sup>-</sup>
<b>VOL-MIN:</b>	1.5 L	<b>EXTRACTION SOLUTION:</b>	absorbing solution, 50 mL
<b>-MAX:</b>	6 L	<b>WAVELENGTH:</b>	540 nm
<b>SHIPMENT:</b>	routine	<b>CALIBRATION:</b>	standard solutions of NO <sub>2</sub> <sup>-</sup>
<b>SAMPLE STABILITY:</b>	stable at least 7 days @ 25 °C [1,2]	<b>RANGE:</b>	3 to 18 µg NO <sub>2</sub> <sup>-</sup> per sample [1]
<b>BLANKS:</b>	3 to 6 field blanks and 10 media blanks per set	<b>ESTIMATED LOD:</b>	1 µg NO <sub>2</sub> <sup>-</sup> per sample [3]
<b>ACCURACY</b>		<b>PRECISION (S<sub>r</sub>):</b>	NO: 0.061 [1]; NO <sub>2</sub> : 0.026 [2]
<b>RANGE STUDIED:</b>	NO: 11-48 ppm [1]; NO <sub>2</sub> : 2-12 ppm [2] (1.5-L samples) (3-L samples)		
<b>BIAS:</b>	NO: 4.1% [1]; NO <sub>2</sub> : -2% [2]		
<b>OVERALL PRECISION (S<sub>rt</sub>):</b>	NO: 0.083 [1]; NO <sub>2</sub> : 0.063 [2]		
<b>ACCURACY:</b>	NO: ± 20.4%; NO <sub>2</sub> : ± 14.6%		

**APPLICABILITY:** The working range for NO is 1 to 50 ppm (1.3 to 61 mg/m<sup>3</sup>) for a 1.5-L air sample. The working range for NO<sub>2</sub> is 0.5 to 25 ppm (1 to 47 mg/m<sup>3</sup>) for a 3-L air sample. The lower sampling rate for NO is to allow collection of oxidized NO on the back sorbent section. At the lower rate, both NO and NO<sub>2</sub> may be determined simultaneously.

**INTERFERENCES:** Any compound that reacts with the colorimetric reagents will interfere.

**OTHER METHODS:** This method is based on that of Willey, et al. [4] and combines S321, S320, and P&CAM 231 in a revised format [3,5]. OSHA methods ID-182 and ID-190 use the same sampler, with measurement by ion chromatography [6].

---

**REAGENTS:**

1. Triethanolamine, TEA, reagent grade.
2. n-Butanol, reagent grade.
3. Phosphoric acid,  $H_3PO_4$ , conc., reagent grade.\*
4. N-(1-naphthyl)ethylenediaminedihydrochloride, NEDA.
5. Sodium nitrite,  $NaNO_2$ .
6. Absorbing solution: Dissolve 15.0 g triethanolamine in ca. 500 mL deionized water, add 0.5 mL n-butanol, and dilute to 1 L.
7.  $H_2O_2$  solution, 0.02% (v/v): Dilute 0.2 mL of 30%  $H_2O_2$  to 250 mL with deionized water.
8. Sulfanilamide solution: Dissolve 10 g sulfanilamide in 400 mL deionized water, add 25 mL conc.  $H_3PO_4$ , and dilute to 500 mL.
9. NEDA solution: Dissolve 0.5 g N-(1-naphthyl)ethylenediamine dihydrochloride in 500 mL deionized water.
10. Calibration stock solution, 100  $NO_2^-$   $\mu g/mL$ : Dissolve 0.1500 g  $NaNO_2$  in 1 L deionized water.

\* See SPECIAL PRECAUTIONS.

**EQUIPMENT:**

1. Sampler: Three glass tubes, 7-mm OD, flame-sealed ends with plastic caps, with glass wool retainers:  
Tube A: 400 mg TEA-coated molecular sieve (type 13x, 30-40 mesh)  
Tube B: 800 mg oxidizer (chromate) to convert NO to  $NO_2$ .  
Tube C: Same as Tube A.  
Connect the tubes in series with flexible tubing. Position Tube C closest to the inlet of the sampling pump. Tubes are commercially available (SKC-226-40, or equivalent).
2. Personal sampling pump, 0.025 to 0.2 L/min, with flexible connecting tubing.
3. Spectrophotometer, UV-visible (540 nm), with cuvettes, 1-cm silica cuvettes.
4. Beakers, borosilicate, 100-mL.
5. Volumetric flasks, 50-mL and other convenient sizes.
6. Pipets, 1-, 5-, 10-mL and other convenient sizes.
7. Stopwatch.

---

**SPECIAL PRECAUTIONS:** Concentrated acid is corrosive to the skin and mucous membranes. Handle it only in a hood.

---

**SAMPLING:**

1. Calibrate the sampling pump with a representative sampler in line.
2. Immediately before sampling, break ends of sampler and attach to pump.  
NOTE: Nitrogen dioxide collects on the first tube (Tube A), and is thereby separated from nitric oxide, which is oxidized by Tube B and then is collected on Tube C (adjacent to the sampling pump.)
3. Sample at an accurately known flow rate of 0.025 L/min  $\pm$  5%.  
NOTE: If nitric oxide is not to be determined, a flow rate of up to 0.2 L/min may be used.
4. Cap the sampler and pack securely for shipment. Submit adequate numbers of field blanks and media blanks to the laboratory.

**SAMPLE PREPARATION:**

5. Transfer the sorbent from Tube A and Tube C to separate 50-mL volumetric flasks. Discard glass wool plugs and oxidizer (Tube B).
6. Add absorbing solution to sample in 50-mL volumetric and bring to the mark.
7. Stopper flask and shake vigorously for 30 sec. Allow solids to settle.
8. Pipet 10 mL of extracted sample into a 50-mL volumetric flask.  
NOTE: Start reagent blanks at this step.
9. Add 1.0 mL hydrogen peroxide solution, 10.0 mL sulfanilamide solution, and 1.4 mL NEDA solution. Mix thoroughly after each addition.
10. Allow 10 min for complete color development.

**CALIBRATION AND QUALITY CONTROL:**

11. Calibrate daily with at least six working standards to cover the range of 1 to 18 µg nitrite ion per 10-mL sample.
  - a. Analyze the working standards together with blanks and samples (steps 8 through 10 and steps 12 through 14).
  - b. Prepare a calibration graph [absorbance vs. µg NO<sub>2</sub><sup>-</sup> per sample].

**MEASUREMENT:**

12. Set wavelength on the spectrophotometer to 540 nm.
13. Set to zero with reagent blank.
14. Transfer some of the sample solution from step 10 to a cuvette and record the absorbance.

**CALCULATIONS:**

15. From the calibration graph, determine the mass of NO<sub>2</sub><sup>-</sup> in each Tube A, W<sub>A</sub> (µg), and in the corresponding average blank, B<sub>A</sub> (µg). Similarly, determine the mass of NO<sub>2</sub><sup>-</sup> in each Tube C, W<sub>C</sub> (µg), and average blank, B<sub>C</sub> (µg).
16. Calculate the concentration, C<sub>NO<sub>2</sub></sub> (mg/m<sup>3</sup>) of NO<sub>2</sub> in the volume of air sampled, V (L), applying the conversion factor 0.63:

$$C_{\text{NO}_2} = \frac{(W_A - B_A)}{0.63 V}, \text{ mg/m}^3.$$

NOTE: The conversion factor 0.63 represents the number of moles of nitrite ion produced by 1 mole of nitrogen dioxide gas. For NO or NO<sub>2</sub>, gas concentrations above 10 ppm, use 0.5 as the conversion factor [7].

17. Calculate the concentration, C<sub>NO</sub> (mg/m<sup>3</sup>), of NO in the air volume sampled, V (L), applying the factor 0.652 (MW NO/MW NO<sub>2</sub>) and the conversion factor 0.63:

$$C_{\text{NO}} = \frac{(W_C - B_C) \cdot 0.652}{0.63 V}, \text{ mg/m}^3.$$

**EVALUATION OF METHOD:**

Method S321, Nitric Oxide, was evaluated over the range of 11.1 to 47.7 ppm (13.8 to 58.5 mg/m<sup>3</sup>) for 1.5-L samples, collected from dynamically generated test atmospheres [1,8]. The test concentration was verified with a direct reading instrument, Energetic Sciences Enolyzer. The 1.2 g oxidizer section was found adequate for a 60-min sampling time. NO samples had a mean recovery of 99.5% after 7 days storage at ambient temperature.

Method S320, Nitrogen Dioxide, was evaluated over the range 3.0 - 11.6 ppm (5.8 to 21.6 mg/m<sup>3</sup>) using 3.9-L samples [2,7]. When an atmosphere at 84% RH containing 11.59 ppm NO<sub>2</sub> was sampled at 0.064 L/min, 1.0% breakthrough occurred after 60 min and 2.4% breakthrough occurred after 180 min. Quantitative recovery was obtained for samples containing 47 µg NO<sub>2</sub> which were stored for 12 days at ambient conditions.



**REFERENCES:**

- [1] Backup Data Report for Nitric Oxide, S321, prepared under NIOSH Contract No. 210-76-0123.
- [2] Backup Data Report for Nitrogen Dioxide, S320, prepared under NIOSH Contract No. 210-76-0123.
- [3] NIOSH Manual of Analytical Methods, 2nd ed., Vol. 4, Methods S320 and S321. U.S. Department of Health, Education, and Welfare. DHEW (NIOSH) Publication No. 78-175.
- [4] Willey, M.A., C.S. McCammon, and L.J. Doemeny, Am. Ind. Hyg. Assoc. J. **38**, 358 (1977).
- [5] NIOSH Manual of Analytical Methods, 2nd ed., Vol. 1, P&CAM 231, U.S. Department of Health, Education, and Welfare (NIOSH) Publ. 77-157-A (1977).
- [6] OSHA Analytical Methods Manual, 2nd ed., Part 2, Vol. 2, ID-182 and ID-190, U.S. Department of Labor, Salt Lake City, UT (1991).
- [7] Gold, A., Anal. Chem. **49**, 1443-1450 (1977).
- [8] NIOSH Research Report - Development and Validation of Methods for Sampling and Analysis of Workplace Toxic Substances, U.S. Department of Health and Human Services, Publ. (NIOSH) 80-133 (1980).

**METHOD REVISED BY:**

W. J. Woodfin and M. E. Cassinelli, NIOSH/DPSE; Method S321 validated under NIOSH Contract No. 210-76-0123.



**DIESEL PARTICULATE MATTER  
(as Elemental Carbon)**

**5040**

C                      AW: 12.01                      CAS: none                      RTECS: none

METHOD: 5040: Issue 3                      EVALUATION: FULL                      Issue 1: 15 May 1996  
Issue 3: 15 March 2003

OSHA: no PEL                      PROPERTIES: nonvolatile solid  
NIOSH: no REL  
ACGIH: 20 µg/m<sup>3</sup> as elemental carbon (proposed [1])

SYNONYMS (related terms): diesel particulate matter, diesel exhaust, diesel soot, diesel emissions

SAMPLING		MEASUREMENT	
<b>SAMPLER:</b>	FILTER: quartz-fiber, 37-mm; size-selective sampler may be required [2].	<b>TECHNIQUE:</b>	Thermal-optical analysis; flame ionization detector (FID)
<b>FLOW RATE:</b>	2 to 4 L/min (typical)	<b>ANALYTE:</b>	Elemental carbon (EC). Total carbon is determined, but an EC exposure marker was proposed. See [2] for details.
<b>VOL-MIN:</b>	142 L @ 40 µg/m <sup>3</sup>	<b>FILTER PUNCH SIZE:</b>	1.5 cm <sup>2</sup> (or other [2])
<b>-MAX:</b>	19 m <sup>3</sup> (for filter load of ~ 90 µg/cm <sup>2</sup> )	<b>CALIBRATION:</b>	Methane injection
<b>SHIPMENT:</b>	Routine	<b>RANGE:</b>	1 to 105 µg per filter portion (See also [2].)
<b>SAMPLE STABILITY:</b>	Stable	<b>ESTIMATED LOD:</b>	0.3 µg per filter portion
<b>BLANKS:</b>	2 to 10 field blanks per set	<b>PRECISION (S<sub>r</sub>):</b>	0.19 @ 1 µg C, 0.01 @ 10 to 72 µg C
ACCURACY			
<b>RANGE STUDIED:</b>	23 to 240 µg/m <sup>3</sup> (See also ref. [2].)		
<b>BIAS:</b>	None (See also ref. [2].)		
<b>OVERALL PRECISION (S<sub>r</sub>):</b>	0.085 at 23 µg/m <sup>3</sup> (See also ref. [2].)		
<b>ACCURACY:</b>	± 16.7% at 23 µg/m <sup>3</sup> (See also ref. [2].)		

**APPLICABILITY:** The working range is approximately 6 to 630 µg/m<sup>3</sup>, with an LOD of ~ 2 µg/m<sup>3</sup> for a 960-L air sample collected on a 37-mm filter with a 1.5 cm<sup>2</sup> punch from the sample filter. If a lower LOD is desired, a larger sample volume and/or 25-mm filter may be used (e.g., a 1920-L sample on 25-mm filter gives an LOD of 0.4 µg/m<sup>3</sup>). The split between organic carbon (OC) and EC may be inaccurate if the sample transmittance is too low. The EC loading at which this occurs depends on laser intensity. In general, the OC-EC split may be inaccurate when EC loadings are above 20 µg/cm<sup>2</sup>. High loadings can give low (and variable) EC results because the transmittance remains low and relatively constant until some of the EC is oxidized. The split should be reassigned (prior to EC peak) in such cases [3]. An upper EC limit of 800 µg/m<sup>3</sup> (90 µg/cm<sup>2</sup>) can be determined.

**INTERFERENCES:** Total carbon (as OC and EC) is determined by the method, but EC was recommended as a measure of workplace exposure because OC interferences may be present [2, 3]. Cigarette smoke and carbonates ordinarily do not interfere in the EC determination. Less than 1% of the carbon in cigarette smoke is elemental. If heavy loadings of carbonate are anticipated, a size-selective sampler (impactor and/or cyclone) should be used [2]. For measurement of diesel-source EC in coal mines, a cyclone and impactor with a submicrometer cutpoint are required to minimize collection of coal dust. A cyclone and/or impactor may be necessary in other workplaces if EC-containing dusts are present.

**OTHER METHODS:** Other methods for determination of EC and OC have been employed, but these are not equivalent to the method described herein. Information on other methods is summarized elsewhere [2].

**REAGENTS:**

1. Aqueous solutions of reagent grade (99+%) sucrose, 0.1 to 3 mg C per mL solution. Ensure filter spike loading range brackets that of samples.
2. Ultra pure H<sub>2</sub>O, Type I, or equivalent.
3. UHP helium (99.999%), scrubber also required for removal of oxygen.
4. Hydrogen, purified (99.995%), cylinder or hydrogen generator source.
5. Ultra Zero air (low hydrocarbon).
6. 10% oxygen in helium balance, both gases UHP, certified mix.
7. 5% methane in helium balance, both gases UHP, certified mix.

**EQUIPMENT:**

1. Sampler: Quartz-fiber filter, precleaned (in low temperature asher 2 to 3 h, or muffle furnace for 1 to 2 h at ~ 800 °C), 37-mm, in a 3-piece cassette with filter support (stainless steel screen, cellulose pad, or a second quartz filter). Alternative samplers may be required in dusty environments. See ref. [2] for details.

NOTE 1: High purity, high efficiency, binder-free quartz-fiber filters must be used (e.g., Pall Gelman Sciences Pallflex Tissuequartz 2500QAT-UP). Precleaned filters are available from several laboratories. Filters also can be purchased and cleaned in-house. Filters should be cleaned in a muffle furnace operated at 800-900°C for 1-2 hours. Check (analyze) filters to ensure removal of OC contaminants. A shorter cleaning period may be effective. OC results immediately after cleaning should be below 0.1 µg/cm<sup>2</sup>. OC vapors readily adsorb onto clean filters. Even when stored in closed containers, OC loadings may range from 0.5 µg/cm<sup>2</sup> after several weeks.

NOTE 2: Cellulose supports give higher OC blanks than screens and quartz filters. Bottom quartz filters can be used to correct for adsorbed vapor; see ref. [2].

2. Personal sampling pump with flexible tubing.
3. Thermal-optical analyzer; see ref. [2].
4. Metal punch for removal of 1.5 cm<sup>2</sup> rectangular portion of filter.

NOTE: A smaller portion (e.g., taken with cork borer) may be used, but the area must be large enough to accommodate the entire laser beam (i.e., beam should pass through the sample, not around it). The area of the portion must be accurately known, and the sample must be carefully positioned (the filter transmittance will decrease dramatically when the sample is properly aligned). A filter portion ≥ 0.5 cm<sup>2</sup> with diameter or width ≤ 1 cm is recommended.

5. Syringe, 10-µL.
6. Aluminum foil.
7. Needle (for lifting filter punch portion).
8. Forceps
9. Volumetric flasks, Class A.
10. Analytical balance.

**SPECIAL PRECAUTIONS:** Hydrogen is a flammable gas. Users must be familiar with the proper use of flammable and nonflammable gases, cylinders, and regulators. According to the instrument manufacturer, the instrument is a Class I Laser Product. This designation means there is no laser radiation exposure during normal operation. Weakly scattered laser light is visible during operation, but does not pose a hazard to the user. The internal laser source is a Class IIIb product, which poses a possible hazard to the eye if viewed directly or from a mirror-like surface (i.e., specular reflections). Class IIIb lasers normally do not produce a hazardous diffuse reflection. Repairs to the optical system, and other repairs requiring removal of the instrument housing, should be performed only by a qualified service technician.

**SAMPLING:**

1. Calibrate each personal sampling pump with a representative sampler in line.

**NOTE:** Both open- and closed-faced cassettes have been used. Both configurations generally give even deposits. At higher flow rates (e.g., 4 L/min), small spots occasionally have been observed in the center of the filters when closed-faced cassettes are used. This material likely consisted of impacted diesel agglomerates and/or non-diesel particulate matter. EC results for multiple portions of the filters were in good agreement, so the spots had little analytical impact. Other samplers also can be used (see ref. [2]) provided an even deposit of diesel particulate results. An even deposit is necessary because the sample portion analyzed must be representative of the entire deposit. If the deposit is not homogeneous, the entire sample must be analyzed. An impactor/cyclone may be needed in some cases. [2]

2. Attach sampler outlet to personal sampling pump with flexible tubing.
3. Sample at an accurately known flow rate. Typical rates are 2-4 L/min (note: Lower flows (e.g., 1 L/min) have been used in mines to prevent overloading).
4. After sampling, replace top piece of cassette, if removed, and pack securely for shipment to laboratory.

**NOTE:** Diesel particulate samples from occupational settings generally do not require refrigerated shipment unless there is potential for exposure to elevated temperatures (that is, well above collection temperature). Filter samples normally are stable under laboratory conditions. Some OC loss may occur over time if samples contain OC from other sources (for example, cigarette smoke). Sorption of OC vapor after sample collection has not occurred, even with samples having high (e.g., 80%) EC content.

**SAMPLE PREPARATION:**

5. Place sample filter on a freshly cleaned aluminum foil surface. Isopropyl alcohol or acetone can be used to clean the foil. Allow residual solvent to vaporize from the surface prior to use. Punch out a representative portion of the filter. Take care not to disturb deposited material and avoid hand contact with sample. A needle inserted at an angle is useful for removal of the filter portion from the punch body. Newer instruments have an externally mounted bracket to support the quartz sample holder while the previous sample is removed and a new one is loaded. Through a hole in the side of the standard punch, a needle can be used to push the filter portion from the punch onto the sample holder. Alternative approaches also can be used, depending on the user's preference, as long as contamination is avoided.

**CALIBRATION AND QUALITY CONTROL:**

6. Analyze at least one replicate sample. For sets of up to 50 samples, replicate 10% of the samples. For sets over 50 samples, replicate 5% of the samples. If a filter deposit appears uneven (this should not be the case if the cassette is sealed properly), take a second portion (step 5) for analysis to check evenness of deposition.

**NOTE:** Precision of replicate analyses of a filter is usually better than 5% (1 to 3% is typical).

7. Analyze three quality control blind spikes and three analyst spikes to ensure that instrument calibration is in control. Prepare spike as follows:
  - a. With 10- $\mu$ L (or other) syringe, apply an aliquot of OC standard solution directly to filter portion taken (step 5) from a precleaned filter. For best results, the precleaned filter punch should be cleaned again in the sample oven prior to application of the aliquot.
 

NOTE: With small aliquots (e.g.,  $\leq 10 \mu\text{L}$ ), disperse standard solution over one end of filter portion to ensure standard is in laser beam. To prevent possible solution loss to surface, hold the portion off the surface. Larger volumes can easily penetrate to the underside of the filter portion.
  - b. Allow water to evaporate and analyze spikes with samples and blanks (steps 9 and 10).
 

NOTE: A pronounced decrease in filter transmittance during the *first* temperature step of the analysis indicates water loss. Allow portions to dry longer if this occurs. Spiked punches also can be dried in the oven, if desired. For quick drying, the 'clean oven' command on the menu can be selected and canceled after about 4 seconds. The time allowed may depend on instrument, but oven temperatures should be below 100 °C to avoid boiling the solution. This approach is convenient and prevents potential adsorption of organic vapors in laboratory air.
8. Determine instrument blank (results of analysis with freshly cleaned filter portion) for each sample set.

#### MEASUREMENT:

9. Adjust analyzer settings according to manufacturer's recommendations (see instrument operation manual and background information in ref. [2]). Place sample portion into sample oven.
 

NOTE: Forms of carbon that are difficult to oxidize (e.g., graphite) may require a longer period and higher temperature during the oxidative mode to ensure that all EC is removed (the EC peak should never merge with the calibration peak). Adjust time and temperature accordingly. A maximum temperature above 940 °C should not be required.
10. Determine EC (and OC) mass,  $\mu\text{g}$ . Analyzer results are reported in units  $\mu\text{g}/\text{cm}^2$  of C. The reported values are normally based on a sample portion of about 1.5  $\text{cm}^2$ , which is the area of the standard punch provided by the manufacturer. If the portion area used differs from the value entered in the oecpar.txt file, multiply the result by 1.5 (or value in oecpar.txt file) and divide the product by the actual area analyzed to obtain the area-corrected result (i.e., reported result  $\times$  1.5/portion area = corrected result in  $\mu\text{g}/\text{cm}^2$ ). This is most easily done in the data spreadsheet. Alternatively, the correct results will be obtained with the data calculation program if the portion area is entered in the parameter file (oecpar.txt), but this approach is cumbersome when punches of different areas are used because correct results will not be obtained for all punch sizes.

#### CALCULATIONS:

11. Multiply the reported (or area-corrected) EC result ( $\mu\text{g}/\text{cm}^2$ ) by filter *deposit area*,  $\text{cm}^2$ , (typically 8.5  $\text{cm}^2$  for a 37-mm filter) to calculate total mass,  $\mu\text{g}$ , of EC on each filter sample ( $W_{\text{EC}}$ ). Do the same for the blanks and calculate the mass found in the average field blank ( $W_b$ ). The mass of OC is calculated similarly, but the mean OC field blank may underestimate the amount of OC contributed by adsorbed vapor. A quartz filter placed beneath the sample filter can provide a better estimate of the adsorbed OC. [2]
12. Calculate the EC concentration ( $C_{\text{EC}}$ ) in the air volume sampled, V (L):

$$C_{\text{EC}} = \frac{W_{\text{EC}} - W_b}{V}, \text{mg} / \text{m}^3$$

**EVALUATION OF METHOD:**

Details on the evaluation of this method are provided in a chapter of this NMAM Supplement. [2] The chapter includes a summary of interlaboratory comparison work conducted since the initial publication of the method. Background information and guidance on method use, including sampling requirements, also are provided. In general industry, 37-mm cassettes are normally suitable for air sampling, but there are exceptions. A cyclone in series with an impactor having a submicrometer cutpoint must be used in coal mines, and the Mine Safety and Health Administration (MSHA) has recommended use of a cyclone-impactor sampler in metal and nonmetal mines. [5] The impactor is commercially available [6]. A size-selective sampler (either impactor and/or cyclone) also may be required in other dusty environments [2], particularly if the dust is carbonaceous. If a sample contains carbonate, the carbonate carbon (CC) will be quantified as OC. A carbonate-subtracted result can be obtained through acidification of the sample portion or through separate integration of the carbonate peak [2] (*note: Trona and other compounds containing sodium can etch the quartz oven wall at elevated temperatures. Avoid spillage of these materials in the sample oven.*) These procedures are described in a Chapter of this Supplement. [2] The thermal-optical method is applicable to nonvolatile carbon species (i.e., particulate OC, CC and EC). The method is not appropriate for volatile or semivolatiles, which require sorbents for efficient collection.

**REFERENCES:**

- [1] ACGIH [2001]. Cincinnati, OH: American Conference of Environmental Industrial Hygienists. Diesel Exhaust (Particulate and Particulate Adsorbed Components), Draft TLV-TWA Document, 2001.  
NOTE: Recently, diesel exhaust has been taken off the ACGIH Notice of Intended Changes list. See reference [2].
- [2] NIOSH [2003]. Manual of Analytical Methods (NMAM). O'Connor PF, Schlecht, PC, Monitoring of Diesel Particulate Exhaust in the Workplace, *Chapter Q*, Third Supplement to NMAM, 4<sup>th</sup> Edition, NIOSH, Cincinnati, OH. DHHS (NIOSH) Publication No. 2003-154.
- [3] Birch, ME, Cary, RA [1996]. Elemental Carbon-based Method for Monitoring Occupational Exposures to Particulate Diesel Exhaust Aerosol *Sci Technol* 25:221-241.
- [4] Birch, ME [1998]. Analysis of carbonaceous aerosols: interlaboratory comparison, *Analyst*, 123:851-857.
- [5] Mine Safety and Health Administration (MSHA) [2001]. Department of Labor, 30 CFR Part 57, Diesel Particulate Matter Exposure of Underground Metal and Nonmetal Miners; Final Rule, *Federal Register Vol. 66, No. 13, January 19*.
- [6] SKC, Eight Sixty Three Valley View Road, Eighty Four, PA 15330.

**METHOD WRITTEN BY:**

M. Eileen Birch, Ph.D., NIOSH/DART

**Compendium of Methods  
for the Determination of  
Toxic Organic Compounds  
in Ambient Air**

**Second Edition**

**Compendium Method TO-15**

**Determination Of Volatile Organic  
Compounds (VOCs) In Air Collected In  
Specially-Prepared Canisters And  
Analyzed By Gas Chromatography/  
Mass Spectrometry (GC/MS)**

Center for Environmental Research Information  
Office of Research and Development  
U.S. Environmental Protection Agency  
Cincinnati, OH 45268

January 1999

Method TO-15  
Acknowledgements

This Method was prepared for publication in the *Compendium of Methods for the Determination of Toxic Organic Compounds in Ambient Air, Second Edition* (EPA/625/R-96/010b), which was prepared under Contract No. 68-C3-0315, WA No. 3-10, by Midwest Research Institute (MRI), as a subcontractor to Eastern Research Group, Inc. (ERG), and under the sponsorship of the U.S. Environmental Protection Agency (EPA). Justice A. Manning, John O. Burckle, and Scott Hedges, Center for Environmental Research Information (CERI), and Frank F. McElroy, National Exposure Research Laboratory (NERL), all in the EPA Office of Research and Development, were responsible for overseeing the preparation of this method. Additional support was provided by other members of the Compendia Workgroup, which include:

- John O. Burckle, EPA, ORD, Cincinnati, OH
- James L. Cheney, Corps of Engineers, Omaha, NB
- Michael Davis, U.S. EPA, Region 7, KC, KS
- Joseph B. Elkins Jr., U.S. EPA, OAQPS, RTP, NC
- Robert G. Lewis, U.S. EPA, NERL, RTP, NC
- Justice A. Manning, U.S. EPA, ORD, Cincinnati, OH
- William A. McClenny, U.S. EPA, NERL, RTP, NC
- Frank F. McElroy, U.S. EPA, NERL, RTP, NC
- Heidi Schultz, ERG, Lexington, MA
- William T. "Jerry" Winberry, Jr., EnviroTech Solutions, Cary, NC

This Method is the result of the efforts of many individuals. Gratitude goes to each person involved in the preparation and review of this methodology.

Author(s)

- William A. McClenny, U.S. EPA, NERL, RTP, NC
- Michael W. Holdren, Battelle, Columbus, OH

Peer Reviewers

- Karen Oliver, ManTech, RTP, NC
- Jim Cheney, Corps of Engineers, Omaha, NB
- Elizabeth Almasi, Varian Chromatography Systems, Walnut Creek, CA
- Norm Kirshen, Varian Chromatography Systems, Walnut Creek, CA
- Richard Jessor, Graseby, Smyrna, GA
- Bill Taylor, Graseby, Smyrna, GA
- Lauren Drees, U.S. EPA, NRMRL, Cincinnati, OH

Finally, recognition is given to Frances Beyer, Lynn Kaufman, Debbie Bond, Cathy Whitaker, and Kathy Johnson of Midwest Research Institute's Administrative Services staff whose dedication and persistence during the development of this manuscript has enabled its production.

DISCLAIMER

***This Compendium has been subjected to the Agency's peer and administrative review, and it has been approved for publication as an EPA document. Mention of trade names or commercial products does not constitute endorsement or recommendation for use.***

## METHOD TO-15

### Determination of Volatile Organic Compounds (VOCs) In Air Collected In Specially-Prepared Canisters And Analyzed By Gas Chromatography/ Mass Spectrometry (GC/MS)

#### TABLE OF CONTENTS

	<u>Page</u>
1. Scope .....	15-1
2. Summary of Method .....	15-2
3. Significance .....	15-3
4. Applicable Documents .....	15-4
4.1 ASTM Standards .....	15-4
4.2 EPA Documents .....	15-4
5. Definitions .....	15-4
6. Interferences and Contamination .....	15-6
7. Apparatus and Reagents .....	15-6
7.1 Sampling Apparatus .....	15-6
7.2 Analytical Apparatus .....	15-8
7.3 Calibration System and Manifold Apparatus .....	15-10
7.4 Reagents .....	15-10
8. Collection of Samples in Canisters .....	15-10
8.1 Introduction .....	15-10
8.2 Sampling System Description .....	15-11
8.3 Sampling Procedure .....	15-12
8.4 Cleaning and Certification Program .....	15-14
9. GC/MS Analysis of Volatiles from Canisters .....	15-16
9.1 Introduction .....	15-16
9.2 Preparation of Standards .....	15-17
10. GC/MS Operating Conditions .....	15-21
10.1 Preconcentrator .....	15-21
10.2 GC/MS System .....	15-22
10.3 Analytical Sequence .....	15-22
10.4 Instrument Performance Check .....	15-23
10.5 Initial Calibration .....	15-23
10.6 Daily Calibration .....	15-27
10.7 Blank Analyses .....	15-27
10.8 Sample Analysis .....	15-28



**TABLE OF CONTENTS (continued)**

	<u>Page</u>
11. Requirements for Demonstrating Method Acceptability for VOC Analysis from Canisters .....	15-31
11.1 Introduction .....	15-31
11.2 Method Detection Limit .....	15-31
11.3 Replicate Precision .....	15-31
11.4 Audit Accuracy .....	15-32
12. References .....	15-32

## METHOD TO-15

### Determination of Volatile Organic Compounds (VOCs) In Air Collected In Specially-Prepared Canisters And Analyzed By Gas Chromatography/ Mass Spectrometry (GC/MS)

#### 1. Scope

1.1 This method documents sampling and analytical procedures for the measurement of subsets of the 97 volatile organic compounds (VOCs) that are included in the 189 hazardous air pollutants (HAPs) listed in Title III of the Clean Air Act Amendments of 1990. VOCs are defined here as organic compounds having a vapor pressure greater than  $10^{-1}$  Torr at 25 °C and 760 mm Hg. Table 1 is the list of the target VOCs along with their CAS number, boiling point, vapor pressure and an indication of their membership in both the list of VOCs covered by Compendium Method TO-14A (1) and the list of VOCs in EPA's Contract Laboratory Program (CLP) document entitled: *Statement-of-Work (SOW) for the Analysis of Air Toxics from Superfund Sites (2)*.

Many of these compounds have been tested for stability in concentration when stored in specially-prepared canisters (see Section 8) under conditions typical of those encountered in routine ambient air analysis. The stability of these compounds under all possible conditions is not known. However, a model to predict compound losses due to physical adsorption of VOCs on canister walls and to dissolution of VOCs in water condensed in the canisters has been developed (3). Losses due to physical adsorption require only the establishment of equilibrium between the condensed and gas phases and are generally considered short term losses, (i.e., losses occurring over minutes to hours). Losses due to chemical reactions of the VOCs with cocollected ozone or other gas phase species also account for some short term losses. Chemical reactions between VOCs and substances inside the canister are generally assumed to cause the gradual decrease of concentration over time (i.e., long term losses over days to weeks). Loss mechanisms such as aqueous hydrolysis and biological degradation (4) also exist. No models are currently known to be available to estimate and characterize all these potential losses, although a number of experimental observations are referenced in Section 8. Some of the VOCs listed in Title III have short atmospheric lifetimes and may not be present except near sources.

1.2 This method applies to ambient concentrations of VOCs above 0.5 ppbv and typically requires VOC enrichment by concentrating up to one liter of a sample volume. The VOC concentration range for ambient air in many cases includes the concentration at which continuous exposure over a lifetime is estimated to constitute a  $10^{-6}$  or higher lifetime risk of developing cancer in humans. Under circumstances in which many hazardous VOCs are present at  $10^{-6}$  risk concentrations, the total risk may be significantly greater.

1.3 This method applies under most conditions encountered in sampling of ambient air into canisters. However, the composition of a gas mixture in a canister, under unique or unusual conditions, will change so that the sample is known not to be a true representation of the ambient air from which it was taken. For example, low humidity conditions in the sample may lead to losses of certain VOCs on the canister walls, losses that would not happen if the humidity were higher. If the canister is pressurized, then condensation of water from high humidity samples may cause fractional losses of water-soluble compounds. Since the canister surface area is limited, all gases are in competition for the available active sites. Hence an absolute storage stability cannot be assigned to a specific gas. Fortunately, under conditions of normal usage for sampling ambient air, most VOCs can be recovered from canisters near their original concentrations after storage times of up to thirty days (see Section 8).

1.4 Use of the Compendium Method TO-15 for many of the VOCs listed in Table 1 is likely to present two difficulties: (1) what calibration standard to use for establishing a basis for testing and quantitation, and (2) how

to obtain an audit standard. In certain cases a chemical similarity exists between a thoroughly tested compound and others on the Title III list. In this case, what works for one is likely to work for the other in terms of making standards. However, this is not always the case and some compound standards will be troublesome. The reader is referred to the Section 9.2 on standards for guidance. Calibration of compounds such as formaldehyde, diazomethane, and many of the others represents a challenge.

1.5 Compendium Method TO-15 should be considered for use when a subset of the 97 Title III VOCs constitute the target list. Typical situations involve ambient air testing associated with the permitting procedures for emission sources. In this case sampling and analysis of VOCs is performed to determine the impact of dispersing source emissions in the surrounding areas. Other important applications are prevalence and trend monitoring for hazardous VOCs in urban areas and risk assessments downwind of industrialized or source-impacted areas.

1.6 Solid adsorbents can be used in lieu of canisters for sampling of VOCs, provided the solid adsorbent packings, usually multisorbent packings in metal or glass tubes, can meet the performance criteria specified in Compendium Method TO-17 which specifically addresses the use of multisorbent packings. The two sample collection techniques are different but become the same upon movement of the sample from the collection medium (canister or multisorbent tubes) onto the sample concentrator. Sample collection directly from the atmosphere by automated gas chromatographs can be used in lieu of collection in canisters or on solid adsorbents.

## 2. Summary of Method

2.1 The atmosphere is sampled by introduction of air into a specially-prepared stainless steel canister. Both subatmospheric pressure and pressurized sampling modes use an initially evacuated canister. A pump ventilated sampling line is used during sample collection with most commercially available samplers. Pressurized sampling requires an additional pump to provide positive pressure to the sample canister. A sample of air is drawn through a sampling train comprised of components that regulate the rate and duration of sampling into the pre-evacuated and passivated canister.

2.2 After the air sample is collected, the canister valve is closed, an identification tag is attached to the canister, and the canister is transported to the laboratory for analysis.

2.3 Upon receipt at the laboratory, the canister tag data is recorded and the canister is stored until analysis. Storage times of up to thirty days have been demonstrated for many of the VOCs (5).

2.4 To analyze the sample, a known volume of sample is directed from the canister through a solid multisorbent concentrator. A portion of the water vapor in the sample breaks through the concentrator during sampling, to a degree depending on the multisorbent composition, duration of sampling, and other factors. Water content of the sample can be further reduced by dry purging the concentrator with helium while retaining target compounds. After the concentration and drying steps are completed, the VOCs are thermally desorbed, entrained in a carrier gas stream, and then focused in a small volume by trapping on a reduced temperature trap or small volume multisorbent trap. The sample is then released by thermal desorption and carried onto a gas chromatographic column for separation.

As a simple alternative to the multisorbent/dry purge water management technique, the amount of water vapor in the sample can be reduced below any threshold for affecting the proper operation of the analytical system by

reducing the sample size. For example, a small sample can be concentrated on a cold trap and released directly to the gas chromatographic column. The reduction in sample volume may require an enhancement of detector sensitivity.

Other water management approaches are also acceptable as long as their use does not compromise the attainment of the performance criteria listed in Section 11. A listing of some commercial water management systems is provided in Appendix A. One of the alternative ways to dry the sample is to separate VOCs from condensate on a low temperature trap by heating and purging the trap.

2.5 The analytical strategy for Compendium Method TO-15 involves using a high resolution gas chromatograph (GC) coupled to a mass spectrometer. If the mass spectrometer is a linear quadrupole system, it is operated either by continuously scanning a wide range of mass to charge ratios (SCAN mode) or by monitoring select ion monitoring mode (SIM) of compounds on the target list. If the mass spectrometer is based on a standard ion trap design, only a scanning mode is used (note however, that the Selected Ion Storage (SIS) mode for the ion trap has features of the SIM mode). Mass spectra for individual peaks in the total ion chromatogram are examined with respect to the fragmentation pattern of ions corresponding to various VOCs including the intensity of primary and secondary ions. The fragmentation pattern is compared with stored spectra taken under similar conditions, in order to identify the compound. For any given compound, the intensity of the primary fragment is compared with the system response to the primary fragment for known amounts of the compound. This establishes the compound concentration that exists in the sample.

Mass spectrometry is considered a more definitive identification technique than single specific detectors such as flame ionization detector (FID), electron capture detector (ECD), photoionization detector (PID), or a multidetector arrangement of these (see discussion in Compendium Method TO-14A). The use of both gas chromatographic retention time and the generally unique mass fragmentation patterns reduce the chances for misidentification. If the technique is supported by a comprehensive mass spectral database and a knowledgeable operator, then the correct identification and quantification of VOCs is further enhanced.

### 3. Significance

3.1 Compendium Method TO-15 is significant in that it extends the Compendium Method TO-14A description for using canister-based sampling and gas chromatographic analysis in the following ways:

- Compendium Method TO-15 incorporates a multisorbent/dry purge technique or equivalent (see Appendix A) for water management thereby addressing a more extensive set of compounds (the VOCs mentioned in Title III of the CAAA of 1990) than addressed by Compendium Method TO-14A. Compendium Method TO-14A approach to water management alters the structure or reduces the sample stream concentration of some VOCs, especially water-soluble VOCs.
- Compendium Method TO-15 uses the GC/MS technique as the only means to identify and quantitate target compounds. The GC/MS approach provides a more scientifically-defensible detection scheme which is generally more desirable than the use of single or even multiple specific detectors.
- In addition, Compendium Method TO-15 establishes method performance criteria for acceptance of data, allowing the use of alternate but equivalent sampling and analytical equipment. There are several new and viable commercial approaches for water management as noted in Appendix A of this method on which to base a VOC monitoring technique as well as other approaches to sampling (i.e., autoGCs and solid

adsorbents) that are often used. This method lists performance criteria that these alternatives must meet to be acceptable alternatives for monitoring ambient VOCs.

- Finally, Compendium Method TO-15 includes enhanced provisions for inherent quality control. The method uses internal analytical standards and frequent verification of analytical system performance to assure control of the analytical system. This more formal and better documented approach to quality control guarantees a higher percentage of good data.

3.2 With these features, Compendium Method TO-15 is a more general yet better defined method for VOCs than Compendium Method TO-14A. As such, the method can be applied with a higher confidence to reduce the uncertainty in risk assessments in environments where the hazardous volatile gases listed in the Title III of the Clean Air Act Amendments of 1990 are being monitored. An emphasis on risk assessments for human health and effects on the ecology is a current goal for the U.S. EPA.

#### 4. Applicable Documents

##### 4.1 ASTM Standards

- **Method D1356** *Definitions of Terms Relating to Atmospheric Sampling and Analysis.*
- **Method E260** *Recommended Practice for General Gas Chromatography Procedures.*
- **Method E355** *Practice for Gas Chromatography Terms and Relationships.*
- **Method D5466** *Standard Test Method of Determination of Volatile Organic Compounds in Atmospheres (Canister Sampling Methodology).*

##### 4.2 EPA Documents

- *Quality Assurance Handbook for Air Pollution Measurement Systems, Volume II*, U. S. Environmental Protection Agency, EPA-600/R-94-038b, May 1994.
- *Technical Assistance Document for Sampling and Analysis of Toxic Organic Compounds in Ambient Air*, U. S. Environmental Protection Agency, EPA-600/4-83-027, June 1983.
- *Compendium of Methods for the Determination of Toxic Organic Compounds in Ambient Air: Method TO-14, Second Supplement*, U. S. Environmental Protection Agency, EPA-600/4-89-018, March 1989.
- *Statement-of-Work (SOW) for the Analysis of Air Toxics from Superfund Sites*, U. S. Environmental Protection Agency, Office of Solid Waste, Washington, D.C., Draft Report, June 1990.
- *Clean Air Act Amendments of 1990*, U. S. Congress, Washington, D.C., November 1990.

#### 5. Definitions

[*Note: Definitions used in this document and any user-prepared standard operating procedures (SOPs) should be consistent with ASTM Methods D1356, E260, and E355. Aside from the definitions given below, all pertinent abbreviations and symbols are defined within this document at point of use.*]

5.1 **Gauge Pressure**—pressure measured with reference to the surrounding atmospheric pressure, usually expressed in units of kPa or psi. Zero gauge pressure is equal to atmospheric (barometric) pressure.

**5.2 Absolute Pressure**—pressure measured with reference to absolute zero pressure, usually expressed in units of kPa, or psi.

**5.3 Cryogen**—a refrigerant used to obtain sub-ambient temperatures in the VOC concentrator and/or on front of the analytical column. Typical cryogenes are liquid nitrogen (bp  $-195.8^{\circ}\text{C}$ ), liquid argon (bp  $-185.7^{\circ}\text{C}$ ), and liquid  $\text{CO}_2$  (bp  $-79.5^{\circ}\text{C}$ ).

**5.4 Dynamic Calibration**—calibration of an analytical system using calibration gas standard concentrations in a form identical or very similar to the samples to be analyzed and by introducing such standards into the inlet of the sampling or analytical system from a manifold through which the gas standards are flowing.

**5.5 Dynamic Dilution**—means of preparing calibration mixtures in which standard gas(es) from pressurized cylinders are continuously blended with humidified zero air in a manifold so that a flowing stream of calibration mixture is available at the inlet of the analytical system.

**5.6 MS-SCAN**—mass spectrometric mode of operation in which the gas chromatograph (GC) is coupled to a mass spectrometer (MS) programmed to SCAN all ions repeatedly over a specified mass range.

**5.7 MS-SIM**—mass spectrometric mode of operation in which the GC is coupled to a MS that is programmed to scan a selected number of ions repeatedly [i.e., selected ion monitoring (SIM) mode].

**5.8 Qualitative Accuracy**—the degree of measurement accuracy required to correctly identify compounds with an analytical system.

**5.9 Quantitative Accuracy**—the degree of measurement accuracy required to correctly measure the concentration of an identified compound with an analytical system with known uncertainty.

**5.10 Replicate Precision**—precision determined from two canisters filled from the same air mass over the same time period and determined as the absolute value of the difference between the analyses of canisters divided by their average value and expressed as a percentage (see Section 11 for performance criteria for replicate precision).

**5.11 Duplicate Precision**—precision determined from the analysis of two samples taken from the same canister. The duplicate precision is determined as the absolute value of the difference between the canister analyses divided by their average value and expressed as a percentage.

**5.12 Audit Accuracy**—the difference between the analysis of a sample provided in an audit canister and the nominal value as determined by the audit authority, divided by the audit value and expressed as a percentage (see Section 11 for performance criteria for audit accuracy).

## 6. Interferences and Contamination

**6.1** Very volatile compounds, such as chloromethane and vinyl chloride can display peak broadening and co-elution with other species if the compounds are not delivered to the GC column in a small volume of carrier gas. Refocusing of the sample after collection on the primary trap, either on a separate focusing trap or at the head of the gas chromatographic column, mitigates this problem.

6.2 Interferences in canister samples may result from improper use or from contamination of: (1) the canisters due to poor manufacturing practices, (2) the canister cleaning apparatus, and (3) the sampling or analytical system. Attention to the following details will help to minimize the possibility of contamination of canisters.

6.2.1 Canisters should be manufactured using high quality welding and cleaning techniques, and new canisters should be filled with humidified zero air and then analyzed, after "aging" for 24 hours, to determine cleanliness. The cleaning apparatus, sampling system, and analytical system should be assembled of clean, high quality components and each system should be shown to be free of contamination.

6.2.2 Canisters should be stored in a contaminant-free location and should be capped tightly during shipment to prevent leakage and minimize any compromise of the sample.

6.2.3 Impurities in the calibration dilution gas (if applicable) and carrier gas, organic compounds out-gassing from the system components ahead of the trap, and solvent vapors in the laboratory account for the majority of contamination problems. The analytical system must be demonstrated to be free from contamination under the conditions of the analysis by running humidified zero air blanks. The use of non-chromatographic grade stainless steel tubing, non-PTFE thread sealants, or flow controllers with Buna-N rubber components must be avoided.

6.2.4 Significant contamination of the analytical equipment can occur whenever samples containing high VOC concentrations are analyzed. This in turn can result in carryover contamination in subsequent analyses. Whenever a high concentration (>25 ppbv of a trace species) sample is encountered, it should be followed by an analysis of humid zero air to check for carry-over contamination.

6.2.5 In cases when solid sorbents are used to concentrate the sample prior to analysis, the sorbents should be tested to identify artifact formation (see Compendium Method TO-17 for more information on artifacts).

## 7. Apparatus and Reagents

*[Note: Compendium Method To-14A list more specific requirements for sampling and analysis apparatus which may be of help in identifying options. The listings below are generic.]*

### 7.1 Sampling Apparatus

*[Note: Subatmospheric pressure and pressurized canister sampling systems are commercially available and have been used as part of U.S. Environmental Protection Agency's Toxic Air Monitoring Stations (TAMS), Urban Air Toxic Monitoring Program (UATMP), the non-methane organic compound (NMOC) sampling and analysis program, and the Photochemical Assessment Monitoring Stations (PAMS).]*

#### 7.1.1 Subatmospheric Pressure (see Figure 1, without metal bellows type pump).

7.1.1.1 **Sampling Inlet Line.** Stainless steel tubing to connect the sampler to the sample inlet.

7.1.1.2 **Sample Canister.** Leak-free stainless steel pressure vessels of desired volume (e.g., 6 L), with valve and specially prepared interior surfaces (see Appendix B for a listing of known manufacturers/resellers of canisters).

7.1.1.3 **Stainless Steel Vacuum/Pressure Gauges.** Two types are required, one capable of measuring vacuum (-100 to 0 kPa or 0 to -30 in Hg) and pressure (0-206 kPa or 0-30 psig) in the sampling system and a second type (for checking the vacuum of canisters during cleaning) capable of measuring at 0.05 mm Hg (see Appendix B) within 20%. Gauges should be tested clean and leak tight.

7.1.1.4 **Electronic Mass Flow Controller.** Capable of maintaining a constant flow rate ( $\pm 10\%$ ) over a sampling period of up to 24 hours and under conditions of changing temperature (20-40°C) and humidity.

7.1.1.5 **Particulate Matter Filter.** 2- $\mu\text{m}$  sintered stainless steel in-line filter.

7.1.1.6 **Electronic Timer.** For unattended sample collection.

7.1.1.7 **Solenoid Valve.** Electrically-operated, bi-stable solenoid valve with Viton® seat and O-rings. A Skinner Magnelatch valve is used for purposes of illustration in the text (see Figure 2).

7.1.1.8 **Chromatographic Grade Stainless Steel Tubing and Fittings.** For interconnections. All such materials in contact with sample, analyte, and support gases prior to analysis should be chromatographic grade stainless steel or equivalent.

7.1.1.9 **Thermostatically Controlled Heater.** To maintain above ambient temperature inside insulated sampler enclosure.

7.1.1.10 **Heater Thermostat.** Automatically regulates heater temperature.

7.1.1.11 **Fan.** For cooling sampling system.

7.1.1.12 **Fan Thermostat.** Automatically regulates fan operation.

7.1.1.13 **Maximum-Minimum Thermometer.** Records highest and lowest temperatures during sampling period.

7.1.1.14 **Stainless Steel Shut-off Valve.** Leak free, for vacuum/pressure gauge.

7.1.1.15 **Auxiliary Vacuum Pump.** Continuously draws air through the inlet manifold at 10 L/min. or higher flow rate. Sample is extracted from the manifold at a lower rate, and excess air is exhausted.

*[Note: The use of higher inlet flow rates dilutes any contamination present in the inlet and reduces the possibility of sample contamination as a result of contact with active adsorption sites on inlet walls.]*

7.1.1.16 **Elapsed Time Meter.** Measures duration of sampling.

7.1.1.17 **Optional Fixed Orifice, Capillary, or Adjustable Micrometering Valve.** May be used in lieu of the electronic flow controller for grab samples or short duration time-integrated samples. Usually appropriate only in situations where screening samples are taken to assess future sampling activity.

7.1.2 **Pressurized (see Figure 1 with metal bellows type pump and Figure 3).**

7.1.2.1 **Sample Pump.** Stainless steel, metal bellows type, capable of 2 atmospheres output pressure. Pump must be free of leaks, clean, and uncontaminated by oil or organic compounds.

*[Note: An alternative sampling system has been developed by Dr. R. Rasmussen, The Oregon Graduate Institute of Science and Technology, 20000 N.W. Walker Rd., Beaverton, Oregon 97006, 503-690-1077, and is illustrated in Figure 3. This flow system uses, in order, a pump, a mechanical flow regulator, and a mechanical compensation flow restrictive device. In this configuration the pump is purged with a large sample flow, thereby eliminating the need for an auxiliary vacuum pump to flush the sample inlet.]*

7.1.2.2 **Other Supporting Materials.** All other components of the pressurized sampling system are similar to components discussed in Sections 7.1.1.1 through 7.1.1.17.

## 7.2 Analytical Apparatus

7.2.1 **Sampling/Concentrator System (many commercial alternatives are available).**

7.2.1.1 **Electronic Mass Flow Controllers.** Used to maintain constant flow (for purge gas, carrier gas and sample gas) and to provide an analog output to monitor flow anomalies.

7.2.1.2 **Vacuum Pump.** General purpose laboratory pump, capable of reducing the downstream pressure of the flow controller to provide the pressure differential necessary to maintain controlled flow rates of sample air.

7.2.1.3 **Stainless Steel Tubing and Stainless Steel Fittings.** Coated with fused silica to minimize active adsorption sites.



**7.2.1.4 Stainless Steel Cylinder Pressure Regulators.** Standard, two-stage cylinder regulators with pressure gauges.

**7.2.1.5 Gas Purifiers.** Used to remove organic impurities and moisture from gas streams.

**7.2.1.6 Six-port Gas Chromatographic Valve.** For routing sample and carrier gas flows.

**7.2.1.7 Multisorbent Concentrator.** Solid adsorbent packing with various retentive properties for adsorbing trace gases are commercially available from several sources. The packing contains more than one type of adsorbent packed in series.

**7.2.1.7.1A** pre-packed adsorbent trap (Supelco 2-0321) containing 200 mg Carboxpack B (60/80 mesh) and 50 mg Carboxieve S-III (60/80 mesh) has been found to retain VOCs and allow some water vapor to pass through (6). The addition of a dry purging step allows for further water removal from the adsorbent trap. The steps constituting the dry purge technique that are normally used with multisorbent traps are illustrated in Figure 4. The optimum trapping and dry purging procedure for the Supelco trap consists of a sample volume of 320 mL and a dry nitrogen purge of 1300 mL. Sample trapping and drying is carried out at 25°C. The trap is back-flushed with helium and heated to 220°C to transfer material onto the GC column. A trap bake-out at 260°C for 5 minutes is conducted after each run.

**7.2.1.7.2A**n example of the effectiveness of dry purging is shown in Figure 5. The multisorbent used in this case is Tenax/Amborsorb 340/Charcoal (7). Approximately 20% of the initial water content in the sample remains after sampling 500 mL of air. The detector response to water vapor (hydrogen atoms detected by atomic emission detection) is plotted versus purge gas volume. Additional water reduction by a factor of 8 is indicated at temperatures of 45°C or higher. Still further water reduction is possible using a two-stage concentration/dryer system.

**7.2.1.8 Cryogenic Concentrator.** Complete units are commercially available from several vendor sources. The characteristics of the latest concentrators include a rapid, "ballistic" heating of the concentrator to release any trapped VOCs into a small carrier gas volume. This facilitates the separation of compounds on the gas chromatographic column.

#### **7.2.2 Gas Chromatographic/Mass Spectrometric (GC/MS) System.**

**7.2.2.1 Gas Chromatograph.** The gas chromatographic (GC) system must be capable of temperature programming. The column oven can be cooled to subambient temperature (e.g., -50°C) at the start of the gas chromatographic run to effect a resolution of the very volatile organic compounds. In other designs, the rate of release of compounds from the focusing trap in a two stage system obviates the need for retrapping of compounds on the column. The system must include or be interfaced to a concentrator and have all required accessories including analytical columns and gases. All GC carrier gas lines must be constructed from stainless steel or copper tubing. Non-polytetrafluoroethylene (PTFE) thread sealants or flow controllers with Buna-N rubber components must not be used.

**7.2.2.2 Chromatographic Columns.** 100% methyl silicone or 5% phenyl, 95% methyl silicone fused silica capillary columns of 0.25- to 0.53-mm I.D. of varying lengths are recommended for separation of many of the possible subsets of target compounds involving nonpolar compounds. However, considering the diversity of the target list, the choice is left to the operator subject to the performance standards given in Section 11.

**7.2.2.3 Mass Spectrometer.** Either a linear quadrupole or ion trap mass spectrometer can be used as long as it is capable of scanning from 35 to 300 amu every 1 second or less, utilizing 70 volts (nominal) electron energy in the electron impact ionization mode, and producing a mass spectrum which meets all the instrument performance acceptance criteria when 50 ng or less of p-bromofluorobenzene (BFB) is analyzed.

**7.2.2.3.1 Linear Quadrupole Technology.** A simplified diagram of the heart of the quadrupole mass spectrometer is shown in Figure 6. The quadrupole consists of a parallel set of four rod electrodes mounted in a square configuration. The field within the analyzer is created by coupling opposite pairs of rods together and applying radiofrequency (RF) and direct current (DC) potentials between the pairs of rods. Ions created in the ion source from the reaction of column eluates with electrons from the electron source are moved through the

parallel array of rods under the influence of the generated field. Ions which are successfully transmitted through the quadrupole are said to possess stable trajectories and are subsequently recorded with the detection system. When the DC potential is zero, a wide band of  $m/z$  values is transmitted through the quadrupole. This "RF only" mode is referred to as the "total-ion" mode. In this mode, the quadrupole acts as a strong focusing lens analogous to a high pass filter. The amplitude of the RF determines the low mass cutoff. A mass spectrum is generated by scanning the DC and RF voltages using a fixed DC/RF ratio and a constant drive frequency or by scanning the frequency and holding the DC and RF constant. With the quadrupole system only 0.1 to 0.2 percent of the ions formed in the ion source actually reach the detector.

**7.2.2.3.2 Ion Trap Technology.** An ion-trap mass spectrometer consists of a chamber formed between two metal surfaces in the shape of a hyperboloid of one sheet (ring electrode) and a hyperboloid of two sheets (the two end-cap electrodes). Ions are created within the chamber by electron impact from an electron beam admitted through a small aperture in one of the end caps. Radio frequency (RF) (and sometimes direct current voltage offsets) are applied between the ring electrode and the two end-cap electrodes establishing a quadrupole electric field. This field is uncoupled in three directions so that ion motion can be considered independently in each direction; the force acting upon an ion increases with the displacement of the ion from the center of the field but the direction of the force depends on the instantaneous voltage applied to the ring electrode. A restoring force along one coordinate (such as the distance,  $r$ , from the ion-trap's axis of radial symmetry) will exist concurrently with a repelling force along another coordinate (such as the distance,  $z$ , along the ion traps axis), and if the field were static the ions would eventually strike an electrode. However, in an RF field the force along each coordinate alternates direction so that a stable trajectory may be possible in which the ions do not strike a surface. In practice, ions of appropriate mass-to-charge ratios may be trapped within the device for periods of milliseconds to hours. A diagram of a typical ion trap is illustrated in Figure 7. Analysis of stored ions is performed by increasing the RF voltage, which makes the ions successively unstable. The effect of the RF voltage on the ring electrode is to "squeeze" the ions in the  $xy$  plane so that they move along the  $z$  axis. Half the ions are lost to the top cap (held at ground potential); the remaining ions exit the lower end cap to be detected by the electron multiplier. As the energy applied to the ring electrode is increased, the ions are collected in order of increasing mass to produce a conventional mass spectrum. With the ion trap, approximately 50 percent of the generated ions are detected. As a result, a significant increase in sensitivity can be achieved when compared to a full scan linear quadrupole system.

**7.2.2.4 GC/MS Interface.** Any gas chromatograph to mass spectrometer interface that gives acceptable calibration points for each of the analytes of interest and can be used to achieve all acceptable performance criteria may be used. Gas chromatograph to mass spectrometer interfaces constructed of all-glass, glass-lined, or fused silica-lined materials are recommended. Glass and fused silica should be deactivated.

**7.2.2.5 Data System.** The computer system that is interfaced to the mass spectrometer must allow the continuous acquisition and storage, on machine readable media, of all mass spectra obtained throughout the duration of the chromatographic program. The computer must have software that allows searching any GC/MS data file for ions of a specified mass and plotting such ion abundances versus time or scan number. This type of plot is defined as a Selected Ion Current Profile (SICP). Software must also be available that allows integrating the abundance in any SICP between specified time or scan number limits. Also, software must be available that allows for the comparison of sample spectra with reference library spectra. The National Institute of Standards and Technology (NIST) or Wiley Libraries or equivalent are recommended as reference libraries.

**7.2.2.6 Off-line Data Storage Device.** Device must be capable of rapid recording and retrieval of data and must be suitable for long-term, off-line data storage.

### 7.3 Calibration System and Manifold Apparatus (see Figure 8)

**7.3.1 Calibration Manifold.** Stainless steel, glass, or high purity quartz manifold, (e.g., 1.25-cm I.D. x 66-cm) with sampling ports and internal baffles for flow disturbance to ensure proper mixing. The manifold should be heated to ~50 °C.

**7.3.2 Humidifier.** 500-mL impinger flask containing HPLC grade deionized water.

**7.3.3 Electronic Mass Flow Controllers.** One 0 to 5 L/min unit and one or more 0 to 100 mL/min units for air, depending on number of cylinders in use for calibration.

**7.3.4 Teflon Filter(s).** 47-mm Teflon® filter for particulate collection.

### 7.4 Reagents

**7.4.1 Neat Materials or Manufacturer-Certified Solutions/Mixtures.** Best source (see Section 9).

**7.4.2 Helium and Air.** Ultra-high purity grade in gas cylinders. He is used as carrier gas in the GC.

**7.4.3 Liquid Nitrogen or Liquid Carbon Dioxide.** Used to cool secondary trap.

**7.4.4 Deionized Water.** High performance liquid chromatography (HPLC) grade, ultra-high purity (for humidifier).

## 8. Collection of Samples in Canisters

### 8.1 Introduction

**8.1.1** Canister samplers, sampling procedures, and canister cleaning procedures have not changed very much from the description given in the original Compendium Method TO-14. Much of the material in this section is therefore simply a restatement of the material given in Compendium Method TO-14, repeated here in order to have all the relevant information in one place.

**8.1.2** Recent notable additions to the canister technology has been in the application of canister-based systems for example, to microenvironmental monitoring (8), the capture of breath samples (9), and sector sampling to identify emission sources of VOCs (10).

**8.1.3** EPA has also sponsored the development of a mathematical model to predict the storage stability of arbitrary mixtures of trace gases in humidified air (3), and the investigation of the SilcoSteel™ process of coating the canister interior with a film of fused silica to reduce surface activity (11). A recent summary of storage stability data for VOCs in canisters is given in the open literature (5).

### 8.2 Sampling System Description

#### 8.2.1 Subatmospheric Pressure Sampling [see Figure 1 (without metal bellows type pump)].

**8.2.1.1** In preparation for subatmospheric sample collection in a canister, the canister is evacuated to 0.05 mm Hg (see Appendix C for discussion of evacuation pressure). When the canister is opened to the atmosphere containing the VOCs to be sampled, the differential pressure causes the sample to flow into the canister. This technique may be used to collect grab samples (duration of 10 to 30 seconds) or time-weighted-average (TWA) samples (duration of 1-24 hours) taken through a flow-restrictive inlet (e.g., mass flow controller, critical orifice).

**8.2.1.2** With a critical orifice flow restrictor, there will be a decrease in the flow rate as the pressure approaches atmospheric. However, with a mass flow controller, the subatmospheric sampling system can maintain a constant flow rate from full vacuum to within about 7 kPa (1.0 psi) or less below ambient pressure.

**8.2.2 Pressurized Sampling [see Figure 1 (with metal bellows type pump)].**

**8.2.2.1** Pressurized sampling is used when longer-term integrated samples or higher volume samples are required. The sample is collected in a canister using a pump and flow control arrangement to achieve a typical 101-202 kPa (15-30 psig) final canister pressure. For example, a 6-liter evacuated canister can be filled at 10 mL/min for 24 hours to achieve a final pressure of 144 kPa (21 psig).

**8.2.2.2** In pressurized canister sampling, a metal bellows type pump draws in air from the sampling manifold to fill and pressurize the sample canister.

**8.2.3 All Samplers.**

**8.2.3.1** A flow control device is chosen to maintain a constant flow into the canister over the desired sample period. This flow rate is determined so the canister is filled (to about 88.1 kPa for subatmospheric pressure sampling or to about one atmosphere above ambient pressure for pressurized sampling) over the desired sample period. The flow rate can be calculated by:

$$F = \frac{P \times V}{T \times 60}$$

where:

F = flow rate, mL/min.

P = final canister pressure, atmospheres absolute. P is approximately equal to

$$\frac{\text{kPa gauge}}{101.2} + 1$$

V = volume of the canister, mL.

T = sample period, hours.

For example, if a 6-L canister is to be filled to 202 kPa (2 atmospheres) absolute pressure in 24 hours, the flow rate can be calculated by:

$$F = \frac{2 \times 6000}{24 \times 60} = 8.3 \text{ mL/min}$$

**8.2.3.2** For automatic operation, the timer is designed to start and stop the pump at appropriate times for the desired sample period. The timer must also control the solenoid valve, to open the valve when starting the pump and to close the valve when stopping the pump.

**8.2.3.3** The use of the Skinner Magnelatch valve (see Figure 2) avoids any substantial temperature rise that would occur with a conventional, normally closed solenoid valve that would have to be energized during the entire sample period. The temperature rise in the valve could cause outgassing of organic compounds from the Viton® valve seat material. The Skinner Magnelatch valve requires only a brief electrical pulse to open or close at the appropriate start and stop times and therefore experiences no temperature increase. The pulses may be obtained either with an electronic timer that can be programmed for short (5 to 60 seconds) ON periods, or with a conventional mechanical timer and a special pulse circuit. A simple electrical pulse circuit for operating the Skinner Magnelatch solenoid valve with a conventional mechanical timer is illustrated in Figure 2(a). However, with this simple circuit, the valve may operate unreliably during brief power interruptions or if the timer is manually switched on and off too fast. A better circuit incorporating a time-delay relay to provide more reliable valve operation is shown in Figure 2(b).

**8.2.3.4** The connecting lines between the sample inlet and the canister should be as short as possible to minimize their volume. The flow rate into the canister should remain relatively constant over the entire sampling period.

**8.2.3.5** As an option, a second electronic timer may be used to start the auxiliary pump several hours prior to the sampling period to flush and condition the inlet line.

**8.2.3.6** Prior to field use, each sampling system must pass a humid zero air certification (see Section 8.4.3). All plumbing should be checked carefully for leaks. The canisters must also pass a humid zero air certification before use (see Section 8.4.1).

### 8.3 Sampling Procedure

**8.3.1** The sample canister should be cleaned and tested according to the procedure in Section 8.4.1.

**8.3.2** A sample collection system is assembled as shown in Figures 1 and 3 and must be cleaned according to the procedure outlined in Sections 8.4.2 and 8.4.4.

*[Note: The sampling system should be contained in an appropriate enclosure.]*

**8.3.3** Prior to locating the sampling system, the user may want to perform "screening analyses" using a portable GC system, as outlined in Appendix B of Compendium Method TO-14A, to determine potential volatile organics present and potential "hot spots." The information gathered from the portable GC screening analysis would be used in developing a monitoring protocol, which includes the sampling system location, based upon the "screening analysis" results.

**8.3.4** After "screening analysis," the sampling system is located. Temperatures of ambient air and sampler box interior are recorded on the canister sampling field test data sheet (FTDS), as documented in Figure 9.

*[Note: The following discussion is related to Figure 1]*

**8.3.5** To verify correct sample flow, a "practice" (evacuated) canister is used in the sampling system.

*[Note: For a subatmospheric sampler, a flow meter and practice canister are needed. For the pump-driven system, the practice canister is not needed, as the flow can be measured at the outlet of the system.]*

A certified mass flow meter is attached to the inlet line of the manifold, just in front of the filter. The canister is opened. The sampler is turned on and the reading of the certified mass flow meter is compared to the sampler mass flow controller. The values should agree within  $\pm 10\%$ . If not, the sampler mass flow meter needs to be recalibrated or there is a leak in the system. This should be investigated and corrected.

*[Note: Mass flow meter readings may drift. Check the zero reading carefully and add or subtract the zero reading when reading or adjusting the sampler flow rate to compensate for any zero drift.]*

After 2 minutes, the desired canister flow rate is adjusted to the proper value (as indicated by the certified mass flow meter) by the sampler flow control unit controller (e.g., 3.5 mL/min for 24 hr, 7.0 mL/min for 12 hr). Record final flow under "CANISTER FLOW RATE" on the FTDS.

**8.3.6** The sampler is turned off and the elapsed time meter is reset to 000.0.

*[Note: Whenever the sampler is turned off, wait at least 30 seconds to turn the sampler back on.]*

8.3.7 The "practice" canister and certified mass flow meter are disconnected and a clean certified (see Section 8.4.1) canister is attached to the system.

8.3.8 The canister valve and vacuum/pressure gauge valve are opened.

8.3.9 Pressure/vacuum in the canister is recorded on the canister FTDS (see Figure 9) as indicated by the sampler vacuum/pressure gauge.

8.3.10 The vacuum/pressure gauge valve is closed and the maximum-minimum thermometer is reset to current temperature. Time of day and elapsed time meter readings are recorded on the canister FTDS.

8.3.11 The electronic timer is set to start and stop the sampling period at the appropriate times. Sampling starts and stops by the programmed electronic timer.

8.3.12 After the desired sampling period, the maximum, minimum, current interior temperature and current ambient temperature are recorded on the FTDS. The current reading from the flow controller is recorded.

8.3.13 At the end of the sampling period, the vacuum/pressure gauge valve on the sampler is briefly opened and closed and the pressure/vacuum is recorded on the FTDS. Pressure should be close to desired pressure.

*[Note: For a subatmospheric sampling system, if the canister is at atmospheric pressure when the field final pressure check is performed, the sampling period may be suspect. This information should be noted on the sampling field data sheet.]*

Time of day and elapsed time meter readings are also recorded.

8.3.14 The canister valve is closed. The sampling line is disconnected from the canister and the canister is removed from the system. For a subatmospheric system, a certified mass flow meter is once again connected to the inlet manifold in front of the in-line filter and a "practice" canister is attached to the Magelatch valve of the sampling system. The final flow rate is recorded on the canister FTDS (see Figure 9).

*[Note: For a pressurized system, the final flow may be measured directly.]*

The sampler is turned off.

8.3.15 An identification tag is attached to the canister. Canister serial number, sample number, location, and date, as a minimum, are recorded on the tag. The canister is routinely transported back to the analytical laboratory with other canisters in a canister shipping case.

#### 8.4 Cleaning and Certification Program

##### 8.4.1 Canister Cleaning and Certification.

8.4.1.1 All canisters must be clean and free of any contaminants before sample collection.

8.4.1.2 All canisters are leak tested by pressurizing them to approximately 206 kPa (30 psig) with zero air.

*[Note: The canister cleaning system in Figure 10 can be used for this task.]*

The initial pressure is measured, the canister valve is closed, and the final pressure is checked after 24 hours. If acceptable, the pressure should not vary more than  $\pm 13.8$  kPa ( $\pm 2$  psig) over the 24 hour period.

8.4.1.3 A canister cleaning system may be assembled as illustrated in Figure 10. Cryogen is added to both the vacuum pump and zero air supply traps. The canister(s) are connected to the manifold. The vent shut-off valve and the canister valve(s) are opened to release any remaining pressure in the canister(s). The vacuum pump is started and the vent shut-off valve is then closed and the vacuum shut-off valve is opened. The canister(s) are evacuated to  $<0.05$  mm Hg (see Appendix B) for at least 1 hour.

*[Note: On a daily basis or more often if necessary, the cryogenic traps should be purged with zero air to remove any trapped water from previous canister cleaning cycles.]*

Air released/evacuated from canisters should be diverted to a fume hood.

**8.4.1.4** The vacuum and vacuum/pressure gauge shut-off valves are closed and the zero air shut-off valve is opened to pressurize the canister(s) with humid zero air to approximately 206 kPa (30 psig). If a zero gas generator system is used, the flow rate may need to be limited to maintain the zero air quality.

**8.4.1.5** The zero air shut-off valve is closed and the canister(s) is allowed to vent down to atmospheric pressure through the vent shut-off valve. The vent shut-off valve is closed. Repeat Sections 8.4.1.3 through 8.4.1.5 two additional times for a total of three (3) evacuation/pressurization cycles for each set of canisters.

**8.4.1.6** At the end of the evacuation/pressurization cycle, the canister is pressurized to 206 kPa (30 psig) with humid zero air. The canister is then analyzed by a GC/MS analytical system. Any canister that has not tested clean (compared to direct analysis of humidified zero air of less than 0.2 ppbv of targeted VOCs) should not be used. As a "blank" check of the canister(s) and cleanup procedure, the final humid zero air fill of 100% of the canisters is analyzed until the cleanup system and canisters are proven reliable (less than 0.2 ppbv of any target VOCs). The check can then be reduced to a lower percentage of canisters.

**8.4.1.7** The canister is reattached to the cleaning manifold and is then reevacuated to <0.05 mm Hg (see Appendix B) and remains in this condition until used. The canister valve is closed. The canister is removed from the cleaning system and the canister connection is capped with a stainless steel fitting. The canister is now ready for collection of an air sample. An identification tag is attached to the inlet of each canister for field notes and chain-of-custody purposes. An alternative to evacuating the canister at this point is to store the canisters and reevacuate them just prior to the next use.

**8.4.1.8** As an option to the humid zero air cleaning procedures, the canisters are heated in an isothermal oven not to exceed 100°C during evacuation of the canister to ensure that higher molecular weight compounds are not retained on the walls of the canister.

*[Note: For sampling more complex VOC mixtures the canisters should be heated to higher temperatures during the cleaning procedure although a special high temperature valve would be needed].*

Once heated, the canisters are evacuated to <0.05 mm Hg (see Appendix B) and maintained there for 1 hour. At the end of the heated/evacuated cycle, the canisters are pressurized with humid zero air and analyzed by a GC/MS system after a minimum of 12 hrs of "aging." Any canister that has not tested clean (less than 0.2 ppbv each of targeted compounds) should not be used. Once tested clean, the canisters are reevacuated to <0.05 mm Hg (see Appendix B) and remain in the evacuated state until used. As noted in Section 8.4.1.7, reevacuation can occur just prior to the next use.

#### **8.4.2 Cleaning Sampling System Components.**

**8.4.2.1** Sample components are disassembled and cleaned before the sampler is assembled. Nonmetallic parts are rinsed with HPLC grade deionized water and dried in a vacuum oven at 50°C. Typically, stainless steel parts and fittings are cleaned by placing them in a beaker of methanol in an ultrasonic bath for 15 minutes. This procedure is repeated with hexane as the solvent.

**8.4.2.2** The parts are then rinsed with HPLC grade deionized water and dried in a vacuum oven at 100°C for 12 to 24 hours.

**8.4.2.3** Once the sampler is assembled, the entire system is purged with humid zero air for 24 hours.

#### **8.4.3 Zero Air Certification.**

[*Note: In the following sections, "certification" is defined as evaluating the sampling system with humid zero air and humid calibration gases that pass through all active components of the sampling system. The system is "certified" if no significant additions or deletions (less than 0.2 ppbv each of target compounds) have occurred when challenged with the test gas stream.*]

**8.4.3.1** The cleanliness of the sampling system is determined by testing the sampler with humid zero air without an evacuated gas sampling canister, as follows.

**8.4.3.2** The calibration system and manifold are assembled, as illustrated in Figure 8. The sampler (without an evacuated gas canister) is connected to the manifold and the zero air cylinder is activated to generate a humid gas stream (2 L/min) to the calibration manifold [see Figure 8(b)].

**8.4.3.3** The humid zero gas stream passes through the calibration manifold, through the sampling system (without an evacuated canister) to the water management system/VOC preconcentrator of an analytical system.

[*Note: The exit of the sampling system (without the canister) replaces the canister in Figure 11.*]

After the sample volume (e.g., 500 mL) is preconcentrated on the trap, the trap is heated and the VOCs are thermally desorbed and refocused on a cold trap. This trap is heated and the VOCs are thermally desorbed onto the head of the capillary column. The VOCs are refocused prior to gas chromatographic separation. Then, the oven temperature (programmed) increases and the VOCs begin to elute and are detected by a GC/MS (see Section 10) system. The analytical system should not detect greater than 0.2 ppbv of any targeted VOCs in order for the sampling system to pass the humid zero air certification test. Chromatograms (using an FID) of a certified sampler and contaminated sampler are illustrated in Figures 12(a) and 12(b), respectively. If the sampler passes the humid zero air test, it is then tested with humid calibration gas standards containing selected VOCs at concentration levels expected in field sampling (e.g., 0.5 to 2 ppbv) as outlined in Section 8.4.4.

#### **8.4.4 Sampler System Certification with Humid Calibration Gas Standards from a Dynamic Calibration System**

**8.4.4.1** Assemble the dynamic calibration system and manifold as illustrated in Figure 8.

**8.4.4.2** Verify that the calibration system is clean (less than 0.2 ppbv of any target compounds) by sampling a humidified gas stream, *without* gas calibration standards, with a previously certified clean canister (see Section 8.1).

**8.4.4.3** The assembled dynamic calibration system is certified clean if less than 0.2 ppbv of any targeted compounds is found.

**8.4.4.4** For generating the humidified calibration standards, the calibration gas cylinder(s) containing nominal concentrations of 10 ppmv in nitrogen of selected VOCs is attached to the calibration system as illustrated in Figure 8. The gas cylinders are opened and the gas mixtures are passed through 0 to 10 mL/min certified mass flow controllers to generate ppb levels of calibration standards.

**8.4.4.5** After the appropriate equilibrium period, attach the sampling system (containing a certified evacuated canister) to the manifold, as illustrated in Figure 8(b).

**8.4.4.6** Sample the dynamic calibration gas stream with the sampling system.

**8.4.4.7** Concurrent with the sampling system operation, realtime monitoring of the calibration gas stream is accomplished by the on-line GC/MS analytical system [Figure 8(a)] to provide reference concentrations of generated VOCs.

**8.4.4.8** At the end of the sampling period (normally the same time period used for experiments), the sampling system canister is analyzed and compared to the reference GC/MS analytical system to determine if the concentration of the targeted VOCs was increased or decreased by the sampling system.

**8.4.4.9** A recovery of between 90% and 110% is expected for all targeted VOCs.

#### **8.4.5 Sampler System Certification without Compressed Gas Cylinder Standards.**



8.4.5.1 Not all the gases on the Title III list are available/compatible with compressed gas standards. In these cases sampler certification must be approached by different means.

8.4.5.2 Definitive guidance is not currently available in these cases; however, Section 9.2 lists several ways to generate gas standards. In general, Compendium Method TO-14A compounds (see Table 1) are available commercially as compressed gas standards.

## 9. GC/MS Analysis of Volatiles from Canisters

### 9.1 Introduction

9.1.1 The analysis of canister samples is accomplished with a GC/MS system. Fused silica capillary columns are used to achieve high temporal resolution of target compounds. Linear quadrupole or ion trap mass spectrometers are employed for compound detection. The heart of the system is composed of the sample inlet concentrating device that is needed to increase sample loading into a detectable range. Two examples of concentrating systems are discussed. Other approaches are acceptable as long as they are compatible with achieving the system performance criteria given in Section 11.

9.1.2 With the first technique, a whole air sample from the canister is passed through a multisorbent packing (including single adsorbent packings) contained within a metal or glass tube maintained at or above the surrounding air temperature. Depending on the water retention properties of the packing, some or most of the water vapor passes completely through the trap during sampling. Additional drying of the sample is accomplished after the sample concentration is completed by forward purging the trap with clean, dry helium or another inert gas (air is not used). The sample is then thermally desorbed from the packing and backflushed from the trap onto a gas chromatographic column. In some systems a "refocusing" trap is placed between the primary trap and the gas chromatographic column. The specific system design downstream of the primary trap depends on technical factors such as the rate of thermal desorption and sampled volume, but the objective in most cases is to enhance chromatographic resolution of the individual sample components before detection on a mass spectrometer.

9.1.3 Sample drying strategies depend on the target list of compounds. For some target compound lists, the multisorbent packing of the concentrator can be selected from hydrophobic adsorbents which allow a high percentage of water vapor in the sample to pass through the concentrator during sampling and without significant loss of the target compounds. However, if very volatile organic compounds are on the target list, the adsorbents required for their retention may also strongly retain water vapor and a more lengthy dry purge is necessary prior to analysis.

9.1.4 With the second technique, a whole air sample is passed through a concentrator where the VOCs are condensed on a reduced temperature surface (cold trap). Subsequently, the condensed gases are thermally desorbed and backflushed from the trap with an inert gas onto a gas chromatographic column. This concentration technique is similar to that discussed in Compendium Method TO-14, although a membrane dryer is not used. The sample size is reduced in volume to limit the amount of water vapor that is also collected (100 mL or less may be necessary). The attendant reduction in sensitivity is offset by enhancing the sensitivity of detection, for example by using an ion trap detector.

## 9.2 Preparation of Standards

### 9.2.1 Introduction.

9.2.1.1 When available, standard mixtures of target gases in high pressure cylinders must be certified traceable to a NIST Standard Reference Material (SRM) or to a NIST/EPA approved Certified Reference Material (CRM). Manufacturer's certificates of analysis must be retained to track the expiration date.

9.2.1.2 The neat standards that are used for making trace gas standards must be of high purity; generally a purity of 98 percent or better is commercially available.

9.2.1.3 Cylinder(s) containing approximately 10 ppmv of each of the target compounds are typically used as primary stock standards. The components may be purchased in one cylinder or in separate cylinders depending on compatibility of the compounds and the pressure of the mixture in the cylinder. Refer to manufacturer's specifications for guidance on purchasing and mixing VOCs in gas cylinders.

### 9.2.2 Preparing Working Standards.

9.2.2.1 **Instrument Performance Check Standard.** Prepare a standard solution of BFB in humidified zero air at a concentration which will allow collection of 50 ng of BFB or less under the optimized concentration parameters.

9.2.2.2 **Calibration Standards.** Prepare five working calibration standards in humidified zero air at a concentration which will allow collection at the 2, 5, 10, 20, and 50 ppbv level for each component under the optimized concentration parameters.

9.2.2.3 **Internal Standard Spiking Mixture.** Prepare an internal spiking mixture containing bromochloromethane, chlorobenzene-d<sub>3</sub>, and 1,4-difluorobenzene at 10 ppmv each in humidified zero air to be added to the sample or calibration standard. 500 µL of this mixture spiked into 500 mL of sample will result in a concentration of 10 ppbv. The internal standard is introduced into the trap during the collection time for all calibration, blank, and sample analyses using the apparatus shown in Figure 13 or by equivalent means. The volume of internal standard spiking mixture added for each analysis must be the same from run to run.

### 9.2.3 Standard Preparation by Dynamic Dilution Technique.

9.2.3.1 Standards may be prepared by dynamic dilution of the gaseous contents of a cylinder(s) containing the gas calibration stock standards with humidified zero air using mass flow controllers and a calibration manifold. The working standard may be delivered from the manifold to a clean, evacuated canister using a pump and mass flow controller.

9.2.3.2 Alternatively, the analytical system may be calibrated by sampling directly from the manifold if the flow rates are optimized to provide the desired amount of calibration standards. However, the use of the canister as a reservoir prior to introduction into the concentration system resembles the procedure normally used to collect samples and is preferred. Flow rates of the dilution air and cylinder standards (all expressed in the same units) are measured using a bubble meter or calibrated electronic flow measuring device, and the concentrations of target compounds in the manifold are then calculated using the dilution ratio and the original concentration of each compound.

$$\text{Manifold Conc.} = \frac{(\text{Original Conc.}) (\text{Std. Gas Flowrate})}{(\text{Air Flowrate}) + (\text{Std. Gas Flowrate})}$$

9.2.3.3 Consider the example of 1 mL/min flow of 10 ppmv standard diluted with 1,000 mL/min of humid air provides a nominal 10 ppbv mixture, as calculated below:

$$\text{Manifold Conc.} = \frac{(10 \text{ ppm})(1 \text{ mL/min})(1000 \text{ ppb/1 ppm})}{(1000 \text{ mL/min}) + (1 \text{ mL/min})} = 10 \text{ ppb}$$

#### 9.2.4 Standard Preparation by Static Dilution Bottle Technique

*[Note: Standards may be prepared in canisters by spiking the canister with a mixture of components prepared in a static dilution bottle (12). This technique is used specifically for liquid standards.]*

**9.2.4.1** The volume of a clean 2-liter round-bottom flask, modified with a threaded glass neck to accept a Mininert septum cap, is determined by weighing the amount of water required to completely fill up the flask. Assuming a density for the water of 1 g/mL, the weight of the water in grams is taken as the volume of the flask in milliliters.

**9.2.4.2** The flask is flushed with helium by attaching a tubing into the glass neck to deliver the helium. After a few minutes, the tubing is removed and the glass neck is immediately closed with a Mininert septum cap.

**9.2.4.3** The flask is placed in a 60°C oven and allowed to equilibrate at that temperature for about 15 minutes. Predetermined aliquots of liquid standards are injected into the flask making sure to keep the flask temperature constant at 60°C.

**9.2.4.4** The contents are allowed to equilibrate in the oven for at least 30 minutes. To avoid condensation, syringes must be preheated in the oven at the same temperature prior to withdrawal of aliquots to avoid condensation.

**9.2.4.5** Sample aliquots may then be taken for introduction into the analytical system or for further dilution. An aliquot or aliquots totaling greater than 1 percent of the flask volume should be avoided.

**9.2.4.6** Standards prepared by this method are stable for one week. The septum must be replaced with each freshly prepared standard.

**9.2.4.7** The concentration of each component in the flask is calculated using the following equation:

$$\text{Concentration, mg/L} = \frac{(V_s)(d)}{V_f}$$

where:  $V_s$  = Volume of liquid neat standard injected into the flask,  $\mu\text{L}$ .

$d$  = Density of the liquid neat standard,  $\text{mg}/\mu\text{L}$ .

$V_f$  = Volume of the flask, L.

**9.2.4.8** To obtain concentrations in ppbv, the equation given in Section 9.2.5.7 can be used.

*[Note: In the preparation of standards by this technique, the analyst should make sure that the volume of neat standard injected into the flask does not result in an overpressure due to the higher partial pressure produced by the standard compared to the vapor pressure in the flask. Precautions should also be taken to avoid a significant decrease in pressure inside the flask after withdrawal of aliquot(s).]*

#### 9.2.5 Standard Preparation Procedure in High Pressure Cylinders

*[Note: Standards may be prepared in high pressure cylinders (13). A modified summary of the procedure is provided below.]*

**9.2.5.1** The standard compounds are obtained as gases or neat liquids (greater than 98 percent purity).

9.2.5.2 An aluminum cylinder is flushed with high-purity nitrogen gas and then evacuated to better than 25 in. Hg.

9.2.5.3 Predetermined amounts of each neat standard compound are measured using a microliter or gastight syringe and injected into the cylinder. The cylinder is equipped with a heated injection port and nitrogen flow to facilitate sample transfer.

9.2.5.4 The cylinder is pressurized to 1000 psig with zero nitrogen.

*[Note: User should read all SOPs associated with generating standards in high pressure cylinders. Follow all safety requirements to minimize danger from high pressure cylinders.]*

9.2.5.5 The contents of the cylinder are allowed to equilibrate (~24 hrs) prior to withdrawal of aliquots into the GC system.

9.2.5.6 If the neat standard is a gas, the cylinder concentration is determined using the following equation:

$$\text{Concentration, ppbv} = \frac{\text{Volume}_{\text{standard}}}{\text{Volume}_{\text{dilution gas}}} \times 10^9$$

*[Note: Both values must be expressed in the same units.]*

9.2.5.7 If the neat standard is a liquid, the gaseous concentration can be determined using the following equations:

$$V = \frac{nRT}{P}$$

and:

$$n = \frac{(\text{mL})(d)}{\text{MW}}$$

where: V = Gaseous volume of injected compound at EPA standard temperature (25°C) and pressure (760 mm Hg), L.

n = Moles.

R = Gas constant, 0.08206 L-atm/mole °K.

T = 298 °K (standard temperature).

P = 1 standard pressure, 760 mm Hg (1 atm).

mL = Volume of liquid injected, mL.

d = Density of the neat standard, g/mL.

MW = Molecular weight of the neat standard expressed, g/g-mole.

The gaseous volume of the injected compound is divided by the cylinder volume at STP and then multiplied by  $10^9$  to obtain the component concentration in ppb units.

### 9.2.6 Standard Preparation by Water Methods.

[*Note: Standards may be prepared by a water purge and trap method (14) and summarized as follows.*]

9.2.6.1 A previously cleaned and evacuated canister is pressurized to 760 mm Hg absolute (1 atm) with zero grade air.

9.2.6.2 The air gauge is removed from the canister and the sparging vessel is connected to the canister with the short length of 1/16 in. stainless steel tubing.

[*Note: Extra effort should be made to minimize possible areas of dead volume to maximize transfer of analytes from the water to the canister.*]

9.2.6.3 A measured amount of the stock standard solution and the internal standard solution is spiked into 5 mL of water.

9.2.6.4 This water is transferred into the sparge vessel and purged with nitrogen for 10 mins at 100 mL/min. The sparging vessel is maintained at 40°C.

9.2.6.5 At the end of 10 mins, the sparge vessel is removed and the air gauge is re-installed, to further pressurize the canister with pure nitrogen to 1500 mm Hg absolute pressure (approximately 29 psia).

9.2.6.6 The canister is allowed to equilibrate overnight before use.

9.2.6.7 A schematic of this approach is shown in Figure 14.

### 9.2.7 Preparation of Standards by Permeation Tubes.

9.2.7.1 Permeation tubes can be used to provide standard concentration of a trace gas or gases. The permeation of the gas can occur from inside a permeation tube containing the trace species of interest to an air stream outside. Permeation can also occur from outside a permeable membrane tube to an air stream passing through the tube (e.g., a tube of permeable material immersed in a liquid).

9.2.7.2 The permeation system is usually held at a constant temperature to generate a constant concentration of trace gas. Commercial suppliers provide systems for generation and dilution of over 250 compounds. Some commercial suppliers of permeation tube equipment are listed in Appendix D.

### 9.2.8 Storage of Standards.

9.2.8.1 Working standards prepared in canisters may be stored for thirty days in an atmosphere free of potential contaminants.

9.2.8.2 It is imperative that a storage logbook be kept to document storage time.

## 10. GC/MS Operating Conditions

### 10.1 Preconcentrator

The following are typical cryogenic and adsorbent preconcentrator analytical conditions which, however, depend on the specific combination of solid sorbent and must be selected carefully by the operator. The reader is referred to Tables 1 and 2 of Compendium Method TO-17 for guidance on selection of sorbents. An example of a system using a solid adsorbent preconcentrator with a cryofocusing trap is discussed in the literature (15). Oven temperature programming starts above ambient.

#### 10.1.1 Sample Collection Conditions

##### Cryogenic Trap

##### Adsorbent Trap

Set point	-150 °C	Set point	27 °C
Sample volume	- up to 100 mL	Sample volume	- up to 1,000 mL
Carrier gas purge flow	- none	Carrier gas purge flow	- selectable

[*Note: The analyst should optimize the flow rate, duration of sampling, and absolute sample volume to be used. Other preconcentration systems may be used provided performance standards (see Section 11) are realized.*]

#### 10.1.2 Desorption Conditions

##### Cryogenic Trap

Desorb Temperature	120 °C
Desorb Flow Rate	~ 3 mL/min He
Desorb Time	<60 sec

##### Adsorbent Trap

Desorb Temperature	Variable
Desorb Flow Rate	~3 mL/min He
Desorb Time	<60 sec

The adsorbent trap conditions depend on the specific solid adsorbents chosen (see manufacturers' specifications).

#### 10.1.3 Trap Reconditioning Conditions.

##### Cryogenic Trap

Initial bakeout	120 °C (24 hrs)
Variable (24 hrs)	
After each run	120 °C (5 min)

##### Adsorbent Trap

Initial bakeout	
After each run	Variable (5 min)

### 10.2 GC/MS System

10.2.1 Optimize GC conditions for compound separation and sensitivity. Baseline separation of benzene and carbon tetrachloride on a 100% methyl polysiloxane stationary phase is an indication of acceptable chromatographic performance.

10.2.2 The following are the recommended gas chromatographic analytical conditions when using a 50-meter by 0.3-mm I.D., 1 µm film thickness fused silica column with refocusing on the column.

<u>Item</u>	<u>Condition</u>
Carrier Gas:	Helium
Flow Rate:	Generally 1-3 mL/min as recommended by manufacturer
Temperature Program:	Initial Temperature: -50 °C
	Initial Hold Time: 2 min
	Ramp Rate: 8 ° C/min
	Final Temperature: 200 °C
	Final Hold Time: Until all target compounds elute.

10.2.3 The following are the recommended mass spectrometer conditions:

<u>Item</u>	<u>Condition</u>
-------------	------------------

Electron Energy:	70 Volts (nominal)
Mass Range:	35-300 amu [the choice of 35 amu excludes the detection of some target compounds such as methanol and formaldehyde, and the quantitation of others such as ethylene oxide, ethyl carbamate, etc. (see Table 2). Lowering the mass range and using special programming features available on modern gas chromatographs will be necessary in these cases, but are not considered here.]
Scan Time:	To give at least 10 scans per peak, not to exceed 1 second per scan].

A schematic for a typical GC/MS analytical system is illustrated in Figure 15.

### 10.3 Analytical Sequence

**10.3.1 Introduction.** The recommended GC/MS analytical sequence for samples during each 24-hour time period is as follows:

- Perform instrument performance check using bromofluorobenzene (BFB).
- Initiate multi-point calibration or daily calibration checks.
- Perform a laboratory method blank.
- Complete this sequence for analysis of  $\leq 20$  field samples.

### 10.4 Instrument Performance Check

**10.4.1 Summary.** It is necessary to establish that a given GC/MS meets tuning and standard mass spectral abundance criteria prior to initiating any data collection. The GC/MS system is set up according to the manufacturer's specifications, and the mass calibration and resolution of the GC/MS system are then verified by the analysis of the instrument performance check standard, bromofluorobenzene (BFB).

**10.4.2 Frequency.** Prior to the analyses of any samples, blanks, or calibration standards, the Laboratory must establish that the GC/MS system meets the mass spectral ion abundance criteria for the instrument performance check standard containing BFB. The instrument performance check solution must be analyzed initially and once per 24-hour time period of operation.

The 24-hour time period for GC/MS instrument performance check and standards calibration (initial calibration or daily calibration check criteria) begins at the injection of the BFB which the laboratory records as documentation of a compliance tune.

**10.4.3 Procedure.** The analysis of the instrument performance check standard is performed by trapping 50 ng of BFB under the optimized preconcentration parameters. The BFB is introduced from a cylinder into the GC/MS via a sample loop valve injection system similar to that shown in Figure 13.

The mass spectrum of BFB must be acquired in the following manner. Three scans (the peak apex scan and the scans immediately preceding and following the apex) are acquired and averaged. Background subtraction is conducted using a single scan prior to the elution of BFB.

**10.4.4 Technical Acceptance Criteria.** Prior to the analysis of any samples, blanks, or calibration standards, the analyst must establish that the GC/MS system meets the mass spectral ion abundance criteria for the instrument performance check standard as specified in Table 3.

**10.4.5 Corrective Action.** If the BFB acceptance criteria are not met, the MS must be retuned. It may be necessary to clean the ion source, or quadrupoles, or take other necessary actions to achieve the acceptance criteria.

**10.4.6 Documentation.** Results of the BFB tuning are to be recorded and maintained as part of the instrumentation log.

### 10.5 Initial Calibration

**10.5.1 Summary.** Prior to the analysis of samples and blanks but after the instrument performance check standard criteria have been met, each GC/MS system must be calibrated at five concentrations that span the monitoring range of interest in an initial calibration sequence to determine instrument sensitivity and the linearity of GC/MS response for the target compounds. For example, the range of interest may be 2 to 20 ppbv, in which case the five concentrations would be 1, 2, 5, 10 and 25 ppbv.

One of the calibration points from the initial calibration curve must be at the same concentration as the daily calibration standard (e.g., 10 ppbv).

**10.5.2 Frequency.** Each GC/MS system must be recalibrated following corrective action (e.g., ion source cleaning or repair, column replacement, etc.) which may change or affect the initial calibration criteria or if the daily calibration acceptance criteria have not been met.

If time remains in the 24-hour time period after meeting the acceptance criteria for the initial calibration, samples may be analyzed.

If time does not remain in the 24-hour period after meeting the acceptance criteria for the initial calibration, a new analytical sequence shall commence with the analysis of the instrument performance check standard followed by analysis of a daily calibration standard.

**10.5.3 Procedure.** Verify that the GC/MS system meets the instrument performance criteria in Section 10.4.

The GC must be operated using temperature and flow rate parameters equivalent to those in Section 10.2.2. Calibrate the preconcentration-GC/MS system by drawing the standard into the system. Use one of the standards preparation techniques described under Section 9.2 or equivalent.

A minimum of five concentration levels are needed to determine the instrument sensitivity and linearity. One of the calibration levels should be near the detection level for the compounds of interest. The calibration range should be chosen so that linear results are obtained as defined in Sections 10.5.1 and 10.5.5.

Quantitation ions for the target compounds are shown in Table 2. The primary ion should be used unless interferences are present, in which case a secondary ion is used.

#### 10.5.4 Calculations.

*[Note: In the following calculations, an internal standard approach is used to calculate response factors. The area response used is that of the primary quantitation ion unless otherwise stated.]*

**10.5.4.1 Relative Response Factor (RRF).** Calculate the relative response factors for each target compound relative to the appropriate internal standard (i.e., standard with the nearest retention time) using the following equation:

$$\text{RRF} = \frac{A_x C_{is}}{A_{is} C_x}$$



where: RRF = Relative response factor.  
 $A_x$  = Area of the primary ion for the compound to be measured, counts.  
 $A_{is}$  = Area of the primary ion for the internal standard, counts.  
 $C_{is}$  = Concentration of internal standard spiking mixture, ppbv.  
 $C_x$  = Concentration of the compound in the calibration standard, ppbv.

[*Note: The equation above is valid under the condition that the volume of internal standard spiking mixture added in all field and QC analyses is the same from run to run, and that the volume of field and QC sample introduced into the trap is the same for each analysis.  $C_{is}$  and  $C_x$  must be in the same units.*]

**10.5.4.2 Mean Relative Response Factor.** Calculate the mean RRF for each compound by averaging the values obtained at the five concentrations using the following equation:

$$\overline{RRF} = \sum_{i=1}^n \frac{x_i}{n}$$

where:  $\overline{RRF}$  = Mean relative response factor.  
 $x_i$  = RRF of the compound at concentration i.  
 $n$  = Number of concentration values, in this case 5.

**10.5.4.3 Percent Relative Standard Deviation (%RSD).** Using the RRFs from the initial calibration, calculate the %RSD for all target compounds using the following equations:

$$\%RSD = \frac{SD_{RRF}}{\overline{RRF}} \times 100$$

and

$$SD_{RRF} = \sqrt{\sum_{i=1}^N \frac{(RRF_i - \overline{RRF})^2}{N - 1}}$$

where:  $SD_{RRF}$  = Standard deviation of initial response factors (per compound).  
 $RRF_i$  = Relative response factor at a concentration level i.  
 $\overline{RRF}$  = Mean of initial relative response factors (per compound).

**10.5.4.4 Relative Retention Times (RRT).** Calculate the RRTs for each target compound over the initial calibration range using the following equation:

$$RRT = \frac{RT_c}{RT_{is}}$$

where:  $RT_c$  = Retention time of the target compound, seconds  
 $RT_{is}$  = Retention time of the internal standard, seconds.

**10.5.4.5 Mean of the Relative Retention Times ( $\overline{RRT}$ ).** Calculate the mean of the relative retention times ( $\overline{RRT}$ ) for each analyte target compound over the initial calibration range using the following equation:

$$\overline{RRT} = \sum_{i=1}^n \frac{RRT_i}{n}$$

where:  $\overline{RRT}$  = Mean relative retention time for the target compound for each initial calibration standard.

RRT = Relative retention time for the target compound at each calibration level.

**10.5.4.6 Tabulate Primary Ion Area Response (Y) for Internal Standard.** Tabulate the area response (Y) of the primary ions (see Table 2) and the corresponding concentration for each compound and internal standard.

**10.5.4.7 Mean Area Response ( $\overline{Y}$ ) for Internal Standard.** Calculate the mean area response ( $\overline{Y}$ ) for each internal standard compound over the initial calibration range using the following equation:

$$\overline{Y} = \sum_{i=1}^n \frac{Y_i}{n}$$

where:  $\overline{Y}$  = Mean area response.

Y = Area response for the primary quantitation ion for the internal standard for each initial calibration standard.

**10.5.4.8 Mean Retention Times ( $\overline{RT}$ ).** Calculate the mean of the retention times ( $\overline{RT}$ ) for each internal standard over the initial calibration range using the following equation:

$$\overline{RT} = \sum_{i=1}^n \frac{RT_i}{n}$$

where:  $\overline{RT}$  = Mean retention time, seconds

RT = Retention time for the internal standard for each initial calibration standard, seconds.

#### 10.5.5 Technical Acceptance Criteria for the Initial Calibration.

**10.5.5.1** The calculated %RSD for the RRF for each compound in the calibration table must be less than 30% with at most two exceptions up to a limit of 40%.

*[Note: This exception may not be acceptable for all projects. Many projects may have a specific target list of compounds which would require the lower limit for all compounds.]*

**10.5.5.2** The RRT for each target compound at each calibration level must be within 0.06 RRT units of the mean RRT for the compound.

**10.5.5.3** The area response Y of at each calibration level must be within 40% of the mean area response  $\overline{Y}$  over the initial calibration range for each internal standard.

**10.5.5.4** The retention time shift for each of the internal standards at each calibration level must be within 20 s of the mean retention time over the initial calibration range for each internal standard.

#### 10.5.6 Corrective Action.

**10.5.6.1 Criteria.** If the initial calibration technical acceptance criteria are not met, inspect the system for problems. It may be necessary to clean the ion source, change the column, or take other corrective actions to meet the initial calibration technical acceptance criteria.

**10.5.6.2 Schedule.** Initial calibration acceptance criteria *must* be met before any field samples, performance evaluation (PE) samples, or blanks are analyzed.

## 10.6 Daily Calibration

**10.6.1 Summary.** Prior to the analysis of samples and blanks but after tuning criteria have been met, the initial calibration of each GC/MS system must be routinely checked by analyzing a daily calibration standard to ensure that the instrument continues to remain under control. The daily calibration standard, which is the nominal 10 ppbv level calibration standard, should contain all the target compounds.

**10.6.2 Frequency.** A check of the calibration curve must be performed once every 24 hours on a GC/MS system that has met the tuning criteria. The daily calibration sequence starts with the injection of the BFB. If the BFB analysis meets the ion abundance criteria for BFB, then a daily calibration standard may be analyzed.

**10.6.3 Procedure.** The mid-level calibration standard (10 ppbv) is analyzed in a GC/MS system that has met the tuning and mass calibration criteria following the same procedure in Section 10.5.

**10.6.4 Calculations.** Perform the following calculations.

*[Note: As indicated earlier, the area response of the primary quantitation ion is used unless otherwise stated.]*

**10.6.4.1 Relative Response Factor (RRF).** Calculate a relative response factor (RRF) for each target compound using the equation in Section 10.5.4.1.

**10.6.4.2 Percent Difference (%D).** Calculate the percent difference in the RRF of the daily RRF (24-hour) compared to the mean RRF in the most recent initial calibration. Calculate the %D for each target compound using the following equation:

$$\%D = \frac{RRF_c - \overline{RRF}_i}{\overline{RRF}_i} \times 100$$

where:  $RRF_c$  = RRF of the compound in the continuing calibration standard.

$\overline{RRF}_i$  = Mean RRF of the compound in the most recent initial calibration.

**10.6.5 Technical Acceptance Criteria.** The daily calibration standard must be analyzed at the concentration level and frequency described in this Section 10.6 and on a GC/MS system meeting the BFB instrument performance check criteria (see Section 10.4).

The %D for each target compound in a daily calibration sequence must be within  $\pm 30$  percent in order to proceed with the analysis of samples and blanks. A control chart showing %D values should be maintained.

**10.6.6 Corrective Action.** If the daily calibration technical acceptance criteria are not met, inspect the system for problems. It may be necessary to clean the ion source, change the column, or take other corrective actions to meet the daily calibration technical acceptance criteria.

Daily calibration acceptance criteria must be met before any field samples, performance evaluation (PE) samples, or blanks are analyzed. If the % D criteria are not met, it will be necessary to rerun the daily calibration sample.

## 10.7 Blank Analyses

**10.7.1 Summary.** To monitor for possible laboratory contamination, laboratory method blanks are analyzed at least once in a 24-hour analytical sequence. All steps in the analytical procedure are performed on the blank

using all reagents, standards, equipment, apparatus, glassware, and solvents that would be used for a sample analysis.

A laboratory method blank (LMB) is an unused, certified canister that has not left the laboratory. The blank canister is pressurized with humidified, ultra-pure zero air and carried through the same analytical procedure as a field sample. The injected aliquot of the blank must contain the same amount of internal standards that are added to each sample.

**10.7.2 Frequency.** The laboratory method blank must be analyzed after the calibration standard(s) and before any samples are analyzed.

Whenever a high concentration sample is encountered (i.e., outside the calibration range), a blank analysis should be performed immediately after the sample is completed to check for carryover effects.

**10.7.3 Procedure.** Fill a cleaned and evacuated canister with humidified zero air (RH >20 percent, at 25°C). Pressurize the contents to 2 atm.

The blank sample should be analyzed using the same procedure outlined under Section 10.8.

**10.7.4 Calculations.** The blanks are analyzed similar to a field sample and the equations in Section 10.5.4 apply.

**10.7.5 Technical Acceptance Criteria.** A blank canister should be analyzed daily.

The area response for each internal standard (IS) in the blank must be within  $\pm 40$  percent of the mean area response of the IS in the most recent valid calibration.

The retention time for each of the internal standards must be within  $\pm 0.33$  minutes between the blank and the most recent valid calibration.

The blank should not contain any target analyte at a concentration greater than its quantitation level (three times the MDL as defined in Section 11.2) and should not contain additional compounds with elution characteristics and mass spectral features that would interfere with identification and measurement of a method analyte.

**10.7.6 Corrective Action.** If the blanks do not meet the technical acceptance criteria, the analyst should consider the analytical system to be out of control. It is the responsibility of the analyst to ensure that contaminants in solvents, reagents, glassware, and other sample storage and processing hardware that lead to discrete artifacts and/or elevated baselines in gas chromatograms be eliminated. If contamination is a problem, the source of the contamination must be investigated and appropriate corrective measures need to be taken and documented before further sample analysis proceeds.

If an analyte in the blank is found to be out of control (i.e., contaminated) and the analyte is also found in associated samples, those sample results should be "flagged" as possibly contaminated.

## 10.8 Sample Analysis

**10.8.1 Summary.** An aliquot of the air sample from a canister (e.g., 500 mL) is preconcentrated and analyzed by GC/MS under conditions stated in Sections 10.1 and 10.2. If using the multisorbent/dry purge approach, adjust the dry purge volume to reduce water effects in the analytical system to manageable levels.

*[Note: The analyst should be aware that pressurized samples of high humidity samples will contain condensed water. As a result, the humidity of the sample released from the canister during analysis will vary*

*in humidity, being lower at the higher canister pressures and increasing in humidity as the canister pressures decreases. Storage integrity of water soluble compounds may also be affected.]*

**10.8.2 Frequency.** If time remains in the 24-hour period in which an initial calibration is performed, samples may be analyzed without analysis of a daily calibration standard.

If time does not remain in the 24-hour period since the injection of the instrument performance check standard in which an initial calibration is performed, both the instrument performance check standard and the daily calibration standard should be analyzed before sample analysis may begin.

**10.8.3 Procedure for Instrumental Analysis.** Perform the following procedure for analysis.

**10.8.3.1** All canister samples should be at temperature equilibrium with the laboratory.

**10.8.3.2** Check and adjust the mass flow controllers to provide correct flow rates for the system.

**10.8.3.3** Connect the sample canister to the inlet of the GC/MS analytical system, as shown in Figure 15 [Figure 16 shows an alternate two stage concentrator using multisorbent traps followed by a trap cooled by a closed cycle cooler (15)]. The desired sample flow is established through the six-port chromatographic valve and the preconcentrator to the downstream flow controller. The absolute volume of sample being pulled through the trap must be consistent from run to run.

**10.8.3.4** Heat/cool the GC oven and cryogenic or adsorbent trap to their set points. Assuming a six-port valve is being used, as soon as the trap reaches its lower set point, the six-port chromatographic valve is cycled to the trap position to begin sample collection. Utilize the sample collection time which has been optimized by the analyst.

**10.8.3.5** Use the arrangement shown in Figure 13, (i.e., a gastight syringe or some alternate method) introduce an internal standard during the sample collection period. Add sufficient internal standard equivalent to 10 ppbv in the sample. For example, a 0.5 mL volume of a mixture of internal standard compounds, each at 10 ppmv concentration, added to a sample volume of 500 mL, will result in 10 ppbv of each internal standard in the sample.

**10.8.3.6** After the sample and internal standards are preconcentrated on the trap, the GC sampling valve is cycled to the inject position and the trap is swept with helium and heated. Assuming a focusing trap is being used, the trapped analytes are thermally desorbed onto a focusing trap and then onto the head of the capillary column and are separated on the column using the GC oven temperature program. The canister valve is closed and the canister is disconnected from the mass flow controller and capped. The trap is maintained at elevated temperature until the beginning of the next analysis.

**10.8.3.7** Upon sample injection onto the column, the GC/MS system is operated so that the MS scans the atomic mass range from 35 to 300 amu. At least ten scans per eluting chromatographic peak should be acquired. Scanning also allows identification of unknown compounds in the sample through searching of library spectra.

**10.8.3.8** Each analytical run must be checked for saturation. The level at which an individual compound will saturate the detection system is a function of the overall system sensitivity and the mass spectral characteristics of that compound.

**10.8.3.9** Secondary ion quantitation is allowed only when there are sample matrix interferences with the primary ion. If secondary ion quantitation is performed, document the reasons in the laboratory record book.

**10.8.4 Calculations.** The equation below is used for calculating concentrations.

$$C_x = \frac{A_x C_{is} DF}{A_{is} RRF}$$

where:  $C_x$  = Compound concentration, ppbv.

$A_x$  = Area of the characteristic ion for the compound to be measured, counts.

$A_{is}$  = Area of the characteristic ion for the specific internal standard, counts.

$C_{is}$  = Concentration of the internal standard spiking mixture, ppbv

$\overline{RRF}$  = Mean relative response factor from the initial calibration.

DF = Dilution factor calculated as described in section 2. If no dilution is performed, DF = 1.

*[Note: The equation above is valid under the condition that the volume (~500  $\mu$ L) of internal standard spiking mixture added in all field and QC analyses is the same from run to run, and that the volume (~500 mL) of field and QC sample introduced into the trap is the same for each analysis.]*

#### 10.8.5 Technical Acceptance Criteria.

*[Note: If the most recent valid calibration is an initial calibration, internal standard area responses and RTs in the sample are evaluated against the corresponding internal standard area responses and RTs in the mid level standard (10 ppbv) of the initial calibration.]*

**10.8.5.1** The field sample must be analyzed on a GC/MS system meeting the BFB tuning, initial calibration, and continuing calibration technical acceptance criteria at the frequency described in Sections 10.4, 10.5 and 10.6.

**10.8.5.2** The field samples must be analyzed along with a laboratory method blank that met the blank technical acceptance criteria.

**10.8.5.3** All of the target analyte peaks should be within the initial calibration range.

**10.8.5.4** The retention time for each internal standard must be within  $\pm 0.33$  minutes of the retention time of the internal standard in the most recent valid calibration.

**10.8.6 Corrective Action.** If the on-column concentration of any compound in any sample exceeds the initial calibration range, an aliquot of the original sample must be diluted and reanalyzed. Guidance in performing dilutions and exceptions to this requirement are given below.

- Use the results of the original analysis to determine the approximate dilution factor required to get the largest analyte peak within the initial calibration range.
- The dilution factor chosen should keep the response of the largest analyte peak for a target compound in the upper half of the initial calibration range of the instrument.

*[Note: Analysis involving dilution should be reported with a dilution factor and nature of the dilution gas.]*

**10.8.6.1** Internal standard responses and retention times must be evaluated during or immediately after data acquisition. If the retention time for any internal standard changes by more than 20 sec from the latest daily (24-hour) calibration standard (or mean retention time over the initial calibration range), the GC/MS system must be inspected for malfunctions, and corrections made as required.

**10.8.6.2** If the area response for any internal standard changes by more than  $\pm 40$  percent between the sample and the most recent valid calibration, the GC/MS system must be inspected for malfunction and

corrections made as appropriate. When corrections are made, reanalysis of samples analyzed while the system was malfunctioning is necessary.

10.8.6.3 If, after reanalysis, the area responses or the RTs for all internal standards are inside the control limits, then the problem with the first analysis is considered to have been within the control of the Laboratory. Therefore, submit only data from the analysis with SICPs within the limits. This is considered the initial analysis and should be reported as such on all data deliverables.

## 11. Requirements for Demonstrating Method Acceptability for VOC Analysis from Canisters

### 11.1 Introduction

11.1.1 There are three performance criteria which must be met for a system to qualify under Compendium Method TO-15. These criteria are: the method detection limit of  $\leq 0.5$  ppbv, replicate precision within 25 percent, and audit accuracy within 30 percent for concentrations normally expected in contaminated ambient air (0.5 to 25 ppbv).

11.1.2 Either SIM or SCAN modes of operation can be used to achieve these criteria, and the choice of mode will depend on the number of target compounds, the decision of whether or not to determine tentatively identified compounds along with other VOCs on the target list, as well as on the analytical system characteristics.

11.1.3 Specific criteria for each Title III compound on the target compound list must be met by the analytical system. These criteria were established by examining summary data from EPA's Toxics Air Monitoring System Network and the Urban Air Toxics Monitoring Program network. Details for the determination of each of the criteria follow.

### 11.2 Method Detection Limit

11.2.1 The procedure chosen to define the method detection limit is that given in the *Code of Federal Regulations* (40 CFR 136 Appendix B).

11.2.2 The method detection limit is defined for each system by making seven replicate measurements of the compound of interest at a concentration near (within a factor of five) the expected detection limit, computing the standard deviation for the seven replicate concentrations, and multiplying this value by 3.14 (i.e., the Student's t value for 99 percent confidence for seven values). Employing this approach, the detection limits given in Table 4 were obtained for some of the VOCs of interest.

### 11.3 Replicate Precision

11.3.1 The measure of replicate precision used for this program is the absolute value of the difference between replicate measurements of the sample divided by the average value and expressed as a percentage as follows:

$$\text{percent difference} = \frac{|x_1 - x_2|}{\bar{x}} \times 100$$

where:  $x_1$  = First measurement value.  
 $x_2$  = Second measurement value.  
 $\bar{x}$  = Average of the two values.

11.3.2 There are several factors which may affect the precision of the measurement. The nature of the compound of interest itself such as molecular weight, water solubility, polarizability, etc., each have some effect on the precision, for a given sampling and analytical system. For example, styrene, which is classified as a polar VOC, generally shows slightly poorer precision than the bulk of nonpolar VOCs. A primary influence on precision is the concentration level of the compound of interest in the sample, i.e., the precision degrades as the concentration approaches the detection limit. A conservative measure was obtained from replicate analysis of "real world" canister samples from the TAMS and UATMP networks. These data are summarized in Table 5 and suggest that a replicate precision value of 25 percent can be achieved for each of the target compounds.

#### 11.4 Audit Accuracy

11.4.1 A measure of analytical accuracy is the degree of agreement with audit standards. Audit accuracy is defined as the difference between the nominal concentration of the audit compound and the measured value divided by the audit value and expressed as a percentage, as illustrated in the following equation:

$$\text{Audit Accuracy, \%} = \frac{\text{Spiked Value} - \text{Observed Value}}{\text{Spiked Value}} \times 100$$

11.4.2 Audit accuracy results for TAMS and UATMP analyses are summarized in Table 6 and were used to form the basis for a selection of 30 percent as the performance criterion for audit accuracy.

#### 12. References

1. *Compendium of Methods for the Determination of Toxic Organic Compounds in Ambient Air: Method TO-14A, Second Edition*, U. S. Environmental Protection Agency, Research Triangle Park, NC, EPA 600/625/R-96/010b, January 1997.
2. Winberry, W. T., Jr., et al., *Statement-of-Work (SOW) for the Analysis of Air Toxics From Superfund Sites*, U. S. Environmental Protection Agency, Office of Solid Waste, Contract Laboratory Program, Washington, D.C., Draft Report, June 1990.
3. Coutant, R.W., *Theoretical Evaluation of Stability of Volatile Organic Chemicals and Polar Volatile Organic Chemicals in Canisters*, U. S. Environmental Protection Agency, EPA Contract No. 68-DO-0007, Work Assignment No. 45, Subtask 2, Battelle, Columbus, OH, June 1993.
4. Kelly, T.J., Mukund, R., Gordon, S.M., and Hays, M.J., *Ambient Measurement Methods and Properties of the 189 Title III Hazardous Air Pollutants*, U. S. Environmental Protection Agency, EPA Contract No. 68-DO-0007, Work Assignment 44, Battelle, Columbus, OH, March 1994.
5. Kelly T. J. and Holdren, M.W., "Applicability of Canisters for Sample Storage in the Determination of Hazardous Air Pollutants," *Atmos. Environ.*, Vol. 29, 2595-2608, May 1995.
6. Kelly, T.J., Callahan, P.J., Pleil, J.K., and Evans, G.E., "Method Development and Field Measurements for Polar Volatile Organic Compounds in Ambient Air," *Environ. Sci. Technol.*, Vol. 27, 1146-1153, 1993.



7. McClenny, W.A., Oliver, K.D. and Daughtrey, E.H., Jr. "Dry Purging of Solid Adsorbent Traps to Remove Water Vapor Before Thermal Desorption of Trace Organic Gases," *J. Air and Waste Manag. Assoc.*, Vol. 45, 792-800, June 1995.
8. Whitaker, D.A., Fortmann, R.C. and Lindstrom, A.B. "Development and Testing of a Whole Air Sampler for Measurement of Personal Exposures to Volatile Organic Compounds," *Journal of Exposure Analysis and Environmental Epidemiology*, Vol. 5, No. 1, 89-100, January 1995.
9. Pleil, J.D. and Lindstrom, A.B., "Collection of a Single Alveolar Exhaled Breath for Volatile Organic Compound Analysis," *American Journal of Industrial Medicine*, Vol. 28, 109-121, 1995.
10. Pleil, J.D. and McClenny, W.A., "Spatially Resolved Monitoring for Volatile Organic Compounds Using Remote Sector Sampling," *Atmos. Environ.*, Vol. 27A, No. 5, 739-747, August 1993.
11. Holdren, M.W., et al., Unpublished Final Report, EPA Contract 68-DO-0007, Battelle, Columbus, OH. Available from J.D. Pleil, MD-44, U. S. Environmental Protection Agency, Research Triangle Park, NC, 27711, 919-541-4680.
12. Morris, C.M., Burkley, R.E. and Bungarner, J.E., "Preparation of Multicomponent Volatile Organic Standards Using Dilution Bottles," *Anal. Letts.*, Vol. 16 (A20), 1585-1593, 1983.
13. Pollack, A.J., Holdren, M.W., "Multi-Adsorbent Preconcentration and Gas Chromatographic Analysis of Air Toxics With an Automated Collection/Analytical System," in the *Proceedings of the 1990 EPA/A&WMA International Symposium on Measurement of Toxic and Related Air Pollutants*, U. S. Environmental Protection Agency, Research Triangle Park, NC, EPA/600/9-90-026, May 1990.
14. Stephenson, J.H.M., Allen, F., Slagle, T., "Analysis of Volatile Organics in Air via Water Methods" in *Proceedings of the 1990 EPA/A&WMA International Symposium on Measurement of Toxic and Related Air Pollutants*, U. S. Environmental Protection Agency, Research Triangle Park, NC, EPA 600/9-90-026, May 1990.
15. Oliver, K. D., Adams, J. R., Davehtrey, E. H., Jr., McClenny, W. A., Young, M. J., and Parade, M. A., "Techniques for Monitoring Toxics VOCs in Air: Sorbent Preconcentration Closed-Cycle Cooler Cryofocusing, and GC/MS Analysis," *Environ. Sci. Technol.*, Vol. 30, 1938-1945, 1996.

## APPENDIX A.

LISTING OF SOME COMMERCIAL WATER  
MANAGEMENT SYSTEMS USED WITH AUTOGC SYSTEMS

Tekmar Dohrman Company  
7143 East Kemper Road  
Post Office Box 429576  
Cincinnati, Ohio 45242-9576  
(513) 247-7000  
(513) 247-7050 (Fax)  
(800) 543-4461  
[Moisture control module]

Entech Laboratory Automation  
950 Enchanted Way No. 101  
Simi Valley, California 93065  
(805) 527-5939  
(805) 527-5687 (Fax)  
[Microscale Purge and Trap]

Dynatherm Analytical Instruments  
Post Office Box 159  
Kelton, Pennsylvania 19346  
(215) 869-8702  
(215) 869-3885 (Fax)  
[Thermal Desorption System]

XonTech Inc.  
6862 Hayenhurst Avenue  
Van Nuys, CA 91406  
(818) 787-7380  
(818) 787-4275 (Fax)  
[Multi-adsorbent trap/dry purge]

Graseby  
500 Technology Ct.  
Smyrna, Georgia 30082  
(770) 319-9999  
(770) 319-0336 (Fax)  
(800) 241-6898  
[Controlled Desorption Trap]

Varian Chromatography System  
2700 Mitchell Drive  
Walnut Creek, California 94898  
(510) 945-2196  
(510) 945-2335 (FAX)  
[Variable Temperature Adsorption Trap]

## APPENDIX B.

## COMMENT ON CANISTER CLEANING PROCEDURES

The canister cleaning procedures given in Section 8.4 require that canister pressure be reduced to <0.05mm Hg before the cleaning process is complete. Depending on the vacuum system design (diameter of connecting tubing, valve restrictions, etc.) and the placement of the vacuum gauge, the achievement of this value may take several hours. In any case, the pressure gauge should be placed near the canisters to determine pressure. The objective of requiring a low pressure evacuation during canister cleaning is to reduce contaminants. If canisters can be routinely certified (<0.2 ppbv for target compounds) while using a higher vacuum, then this criteria can be relaxed. However, the ultimate vacuum achieved during cleaning should always be <0.2mm Hg.

Canister cleaning as described in Section 8.4 and illustrated in Figure 10 requires components with special features. The vacuum gauge shown in Figure 10 must be capable of measuring 0.05mm Hg with less than a 20% error. The vacuum pump used for evacuating the canister must be noncontaminating while being capable of achieving the 0.05 mm Hg vacuum as monitored near the canisters. Thermoelectric vacuum gauges and turbomolecular drag pumps are typically being used for these two components.

An alternate to achieving the canister certification requirement of <0.2 ppbv for all target compounds is the criteria used in Compendium Method TO-12 that the total carbon count be <10ppbC. This check is less expensive and typically more exacting than the current certification requirement and can be used if proven to be equivalent to the original requirement. This equivalency must be established by comparing the total nonmethane organic carbon (TNMOC) expressed in ppbC to the requirement that individual target compounds be <0.2 ppbv for a series of analytical runs.

## APPENDIX C.

LISTING OF COMMERCIAL MANUFACTURERS AND RE-SUPPLIERS OF  
SPECIALLY-PREPARED CANISTERS

BRC/Rasmussen  
17010 NW Skyline Blvd.  
Portland, Oregon 97321  
(503) 621-1435

Meriter  
1790 Potrero Drive  
San Jose, CA 95124  
(408) 265-6482

Restek Corporation  
110 Benner Circle  
Bellefonte, PA 16823-8812  
(814) 353-1300  
(800) 356-1688

Scientific Instrumentation Specialists  
P.O. Box 8941  
815 Courtney Street  
Moscow, ID 83843  
(208) 882-3860

Graseby  
500 Technology Ct.  
Smyrna, Georgia 30082  
(404) 319-9999  
(800) 241-6898

XonTech Inc.  
6862 Hayenhurst Avenue  
Van Nuys, CA 91406  
(818) 787-7380

## APPENDIX D.

## LISTING OF COMMERCIAL SUPPLIERS OF PERMEATION TUBES AND SYSTEMS

Kin-Tek  
504 Laurel St.  
Lamarque, Texas 77568  
(409) 938-3627  
(800) 326-3627

Vici Metronics, Inc.  
2991 Corvin Drive  
Santa Clara, CA 95051  
(408) 737-0550

Analytical Instrument Development, Inc.  
Rt. 41 and Newark Rd.  
Avondale, PA 19311  
(215) 268-3181

Ecology Board, Inc.  
9257 Independence Ave.  
Chatsworth, CA 91311  
(213) 882-6795

Tracor, Inc.  
6500 Tracor Land  
Austin, TX  
(512) 926-2800

Metronics Associates, Inc.  
3201 Porter Drive  
Standford Industrial Park  
Palo Alto, CA 94304  
(415) 493-5632

TABLE 1. VOLATILE ORGANIC COMPOUNDS ON THE TITLE III CLEAN AIR AMENDMENT LIST--  
MEMBERSHIP IN COMPENDIUM METHOD TO-14A LIST AND THE SOW-CLP LIST OF VOCs

Compound	CAS No.	BP (°C)	v.p. (mmHg) <sup>1</sup>	MW <sup>1</sup>	TO-14A	CLP-SOW
Methyl chloride (chloromethane); CH <sub>3</sub> Cl	74-87-3	-23.7	3.8 x 10	50.5	X	X
Carbonyl sulfide; COS	463-58-1	-50.0	3.7 x 10	60.1		
Vinyl chloride (chloroethene); C <sub>2</sub> H <sub>3</sub> Cl	75-01-4	-14.0	3.2 x 10	62.5	X	X
Diazomethane; CH <sub>2</sub> N <sub>2</sub>	334-88-3	-23.0	2.8 x 10	42.1		
Formaldehyde; CH <sub>2</sub> O	50-00-0	-19.5	2.7 x 10	30		
1,3-Butadiene; C <sub>4</sub> H <sub>6</sub>	106-99-0	-4.5	2.0 x 10	54		X
Methyl bromide (bromomethane); CH <sub>3</sub> Br	74-83-9	3.6	1.8 x 10	94.9	X	X
Phosgene; CCl <sub>2</sub> O	75-44-5	8.2	1.2 x 10	99		
Vinyl bromide (bromoethene); C <sub>2</sub> H <sub>3</sub> Br	593-60-2	15.8	1.1 x 10	107		
Ethylene oxide; C <sub>2</sub> H <sub>4</sub> O	75-21-8	10.7	1.1 x 10	44		
Ethyl chloride (chloroethane); C <sub>2</sub> H <sub>5</sub> Cl	75-00-3	12.5	1.0 x 10	64.5	X	X
Acetaldehyde (ethanal); C <sub>2</sub> H <sub>4</sub> O	75-07-0	21.0	952	44		
Vinylidene chloride (1,1-dichloroethylene); C <sub>2</sub> H <sub>2</sub> Cl <sub>2</sub>	75-35-4	31.7	500	97	X	X
Propylene oxide; C <sub>3</sub> H <sub>6</sub> O	75-56-9	34.2	445	58		
Methyl iodide (iodomethane); CH <sub>3</sub> I	74-88-4	42.4	400	141.9		
Methylene chloride; CH <sub>2</sub> Cl <sub>2</sub>	75-09-2	40.0	349	84.9	X	X
Methyl isocyanate; C <sub>2</sub> H <sub>3</sub> NO	624-83-9	59.6	348	57.1		
Allyl chloride (3-chloropropene); C <sub>3</sub> H <sub>5</sub> Cl	107-05-1	44.5	340	76.5	X	X
Carbon disulfide; CS <sub>2</sub>	75-15-0	46.5	260	76		
Methyl tert-butyl ether; C <sub>5</sub> H <sub>12</sub> O	1634-04-4	55.2	249	86		
Propionaldehyde; C <sub>2</sub> H <sub>5</sub> CHO	123-38-6	49.0	235	58.1		
Ethylidene dichloride (1,1-dichloroethane); C <sub>2</sub> H <sub>4</sub> Cl <sub>2</sub>	75-34-3	57.0	230	99	X	

TABLE I. (continued)

Compound	CAS No.	BP (°C)	V.p. (mmHg)	MW <sup>1</sup>	TO-14A	CLP-SOW
Chloroprene (2-chloro-1,3-butadiene); C <sub>4</sub> H <sub>5</sub> Cl	126-99-8	59.4	22.6	88.5		
Chloromethyl methyl ether; C <sub>2</sub> H <sub>5</sub> ClO	107-30-2	59.0	22.4	80.5		
Acrolein (2-propenal); C <sub>3</sub> H <sub>4</sub> O	107-02-8	52.5	22.0	56		X
1,2-Epoxybutane (1,2-butylene oxide); C <sub>4</sub> H <sub>8</sub> O	106-88-7	63.0	16.3	72		
Chloroform; CHCl <sub>3</sub>	67-66-3	61.2	16.0	119	X	X
Ethyleneimine (aziridine); C <sub>2</sub> H <sub>5</sub> N	151-56-4	56	160.0	43		
1,1-Dimethylhydrazine; C <sub>2</sub> H <sub>8</sub> N <sub>2</sub>	57-14-7	63	157.0	60.0		
Hexane; C <sub>6</sub> H <sub>14</sub>	110-54-3	69.0	12.0	86.2	X	
1,2-Propyleneimine (2-methylaziridine); C <sub>3</sub> H <sub>7</sub> N	75-55-8	66.0	11.2	57.1		
Acrylonitrile (2-propenenitrile); C <sub>3</sub> H <sub>3</sub> N	107-13-1	77.3	10.0	53	X	
Methyl chloroform (1,1,1-trichloroethane); C <sub>2</sub> H <sub>3</sub> Cl <sub>3</sub>	71-55-6	74.1	10.0	133.4	X	X
Methanol; CH <sub>4</sub> O	67-56-1	65.0	92.0	32		X
Carbon tetrachloride; CCl <sub>4</sub>	56-23-5	76.7	90.0	153.8	X	X
Vinyl acetate; C <sub>4</sub> H <sub>6</sub> O <sub>2</sub>	108-05-4	72.2	83.0	86		X
Methyl ethyl ketone (2-butanone); C <sub>4</sub> H <sub>8</sub> O	78-93-3	79.6	77.5	72		X
Benzene; C <sub>6</sub> H <sub>6</sub>	71-43-2	80.1	76.0	78	X	X
Acetonitrile (cyanomethane); C <sub>2</sub> H <sub>3</sub> N	75-05-8	82	74.0	41.0		X
Ethylene dichloride (1,2-dichloroethane); C <sub>2</sub> H <sub>4</sub> Cl <sub>2</sub>	107-06-2	83.5	61.5	99	X	X
Triethylamine; C <sub>6</sub> H <sub>15</sub> N	121-44-8	89.5	54.0	101.2		
Methylhydrazine; CH <sub>6</sub> N <sub>2</sub>	60-34-4	87.8	49.6	46.1		
Propylene dichloride (1,2-dichloropropane); C <sub>3</sub> H <sub>6</sub> Cl <sub>2</sub>	78-87-5	97.0	42.0	113	X	X
2,2,4-Trimethyl pentane C <sub>8</sub> H <sub>18</sub>	540-84-1	99.2	40.6	114		
1,4-Dioxane (1,4-Diethylene oxide); C <sub>4</sub> H <sub>8</sub> O <sub>2</sub>	123-91-1	101	37.0	88		
Bis(chloromethyl) ether; C <sub>2</sub> H <sub>4</sub> Cl <sub>2</sub> O	542-88-1	104	30.0	115		
Ethyl acrylate; C <sub>5</sub> H <sub>8</sub> O <sub>2</sub>	140-88-5	100	29.3	100		
Methyl methacrylate; C <sub>5</sub> H <sub>8</sub> O <sub>2</sub>	80-62-6	101	28.0	100.1		

TABLE I. (continued)

Compound	CAS No.	BP (°C)	V.P. (mmHg) <sup>f</sup>	MW <sup>f</sup>	TO-14A	CLP-SOW
Methyl methacrylate; C <sub>5</sub> H <sub>8</sub> O <sub>2</sub>	80-62-101	101	28.0	100.1		
1,3-Dichloropropene; C <sub>3</sub> H <sub>4</sub> Cl <sub>2</sub> (gis)	542-75-6	112	27.8	111	X	X
Toluene; C <sub>7</sub> H <sub>8</sub>	108-88-3	111	22.0	92	X	X
Trichloroethylene; C <sub>2</sub> HCl <sub>3</sub>	79-01-6	87.0	20.0	131.4	X	X
1,1,2-Trichloroethane; C <sub>2</sub> H <sub>3</sub> Cl <sub>3</sub>	79-00-5	114	19.0	133.4	X	X
Tetrachloroethylene; C <sub>2</sub> Cl <sub>4</sub>	127-18-4	121	14.0	165.8	X	X
Epichlorohydrin (1-chloro-2,3-epoxy propane); C <sub>3</sub> H <sub>5</sub> ClO	106-89-8	117	12.0	92.5		
Ethylene dibromide (1,2-dibromoethane); C <sub>2</sub> H <sub>4</sub> Br <sub>2</sub>	106-93-4	132	11.0	187.9	X	X
N-Nitroso-N-methylurea; C <sub>2</sub> H <sub>5</sub> N <sub>3</sub> O <sub>2</sub>	684-93-5	124	10.0	103		
2-Nitropropane; C <sub>3</sub> H <sub>7</sub> NO <sub>2</sub>	79-46-9	120	10.0	89		
Chlorobenzene; C <sub>6</sub> H <sub>5</sub> Cl	108-90-7	132	8.8	112.6	X	X
Ethylbenzene; C <sub>8</sub> H <sub>10</sub>	100-41-4	136	7.0	106	X	X
Xylenes (isomer & mixtures); C <sub>8</sub> H <sub>10</sub>	1330-20-7	142	6.7	106.2	X	X
Styrene; C <sub>8</sub> H <sub>8</sub>	100-42-5	145	6.6	104	X	X
p-Xylene; C <sub>8</sub> H <sub>10</sub>	106-42-3	138	6.5	106.2	X	X
m-Xylene; C <sub>8</sub> H <sub>10</sub>	108-38-3	139	6.0	106.2	X	X
Methyl isobutyl ketone (hexone); C <sub>6</sub> H <sub>12</sub> O	108-10-1	117	6.0	100.2		
Bromoform (tribromomethane); CHBr <sub>3</sub>	75-25-2	149	5.6	252.8		
1,1,2,2-Tetrachloroethane; C <sub>2</sub> H <sub>2</sub> Cl <sub>4</sub>	79-34-5	146	5.0	167.9	X	X
o-Xylene; C <sub>8</sub> H <sub>10</sub>	95-47-6	144	5.0	106.2	X	X
Dimethylcarbamyl chloride; C <sub>3</sub> H <sub>6</sub> ClNO	79-44-7	166	4.9	107.6		
N-Nitrosodimethylamine; C <sub>2</sub> H <sub>6</sub> N <sub>2</sub> O	62-75-9	152	3.7	74		
Beta-Propiolactone; C <sub>3</sub> H <sub>4</sub> O <sub>2</sub>	57-57-8	Decomposes at 162	3.4	72		
Cumene (isopropylbenzene); C <sub>9</sub> H <sub>12</sub>	98-82-8	153	3.2	120		



TABLE I. (continued)

Compound	CAS No.	BP (°C)	v.p. (mmHg) <sup>1</sup>	MW <sup>1</sup>	TO-14A	CLP-SOW
Cumene (isopropylbenzene); C <sub>9</sub> H <sub>12</sub>	98-82-8	153	3.2	120		
Acrylic acid; C <sub>3</sub> H <sub>4</sub> O <sub>2</sub>	79-10-7	141	3.2	72		
N,N-Dimethylformamide; C <sub>3</sub> H <sub>7</sub> NO	68-12-2	153	2.7	73		
1,3-Propane sulfone; C <sub>3</sub> H <sub>6</sub> O <sub>3</sub> S	1120-71-4	180/30mm	2.0	122.1		
Acetophenone; C <sub>8</sub> H <sub>8</sub> O	98-86-2	202	1.0	120		
Dimethyl sulfate; C <sub>2</sub> H <sub>6</sub> O <sub>4</sub> S	77-78-1	188	1.0	126.1		
Benzyl chloride (α-chlorotoluene); C <sub>7</sub> H <sub>7</sub> Cl	100-44-7	179	1.0	126.6	X	X
1,2-Dibromo-3-chloropropane; C <sub>3</sub> H <sub>5</sub> Br <sub>2</sub> Cl	96-12-8	196	0.80	236.4		
Bis(2-Chloroethyl)ether; C <sub>4</sub> H <sub>8</sub> Cl <sub>2</sub> O	111-44-4	178	0.71	143		
Chloroacetic acid; C <sub>2</sub> H <sub>3</sub> ClO <sub>2</sub>	79-11-8	189	0.69	94.5		
Aniline (aminobenzene); C <sub>6</sub> H <sub>7</sub> N	62-53-3	184	0.67	93		
1,4-Dichlorobenzene (p-); C <sub>6</sub> H <sub>4</sub> Cl <sub>2</sub>	106-46-7	173	0.60	147	X	X
Ethyl carbamate (urethane); C <sub>3</sub> H <sub>7</sub> NO <sub>2</sub>	51-79-6	183	0.54	89		
Acrylamide; C <sub>3</sub> H <sub>5</sub> NO	79-06-1	125/25 mm	0.53	71		
N,N-Dimethylamine; C <sub>2</sub> H <sub>7</sub> N	121-69-7	192	0.50	121		
Hexachloroethane; C <sub>2</sub> Cl <sub>6</sub>	67-72-1	Sublimes at 186	0.40	236.7		
Hexachlorobutadiene; C <sub>4</sub> Cl <sub>6</sub>	87-68-3	215	0.40	260.8	X	X
Isophorone; C <sub>9</sub> H <sub>14</sub> O	78-59-1	215	0.38	138.2		
N-Nitrosomorpholine; C <sub>4</sub> H <sub>8</sub> N <sub>2</sub> O <sub>2</sub>	59-89-2	225	0.32	116.1		
Styrene oxide; C <sub>8</sub> H <sub>8</sub> O	96-09-3	194	0.30	120.2		
Diethyl sulfate; C <sub>4</sub> H <sub>10</sub> O <sub>4</sub> S	64-67-5	208	0.29	154		
Cresylic acid (cresol isomer mixture); C <sub>7</sub> H <sub>8</sub> O	1319-77-3	202	0.26	108		
o-Cresol; C <sub>7</sub> H <sub>8</sub> O	95-48-7	191	0.24	108		
Catechol (o-hydroxyphenol); C <sub>6</sub> H <sub>6</sub> O <sub>2</sub>	120-80-9	240	0.22	110		
Phenol; C <sub>6</sub> H <sub>6</sub> O	108-95-2	182	0.20	94		

TABLE I. (continued)

Compound	CAS No.	BP (°C)	v.p. (mmHg) <sup>1</sup>	MW <sup>1</sup>	TO-14A	CLP-SOW
Catechol (o-hydroxyphenol); C <sub>6</sub> H <sub>6</sub> O <sub>2</sub>	120-80-9	240	0.22	110		
Phenol; C <sub>6</sub> H <sub>6</sub> O	108-95-2	182	0.20	94		
1,2,4-Trichlorobenzene; C <sub>6</sub> H <sub>3</sub> Cl <sub>3</sub>	120-82-1	213	0.18	181.5	X	X
nitrobenzene; C <sub>6</sub> H <sub>5</sub> NO <sub>2</sub>	98-95-3	211	0.15	123		

<sup>1</sup>Vapor pressure (v.p.), boiling point (BP) and molecularweight (MW) data from:

- (a) D. L. Jones and J. Bursey, "Simultaneous Control of PM-10 and Hazardous Air Pollutants II: Rationale for Selection of Hazardous Air Pollutants as Potential Particulate Matter," Report EPA-452/R-93/013, U. S. Environmental Protection Agency, Research Triangle Park, NC, October 1992.  
 (b) R. C. Weber, P. A. Parker, and M. Boyser, Vapor Pressure Distribution of Selected Organic Chemicals, Report EPA-600/2-81-021, U. S. Environmental Protection Agency, Cincinnati, OH, February 1981; and  
 (c) R. C. Weast, ed., "CRC Handbook of Chemistry and Physics," 59th edition, CRC Press, Boca Raton, 1979.

TABLE 2. CHARACTERISTIC MASSES (M/Z) USED FOR QUANTIFYING  
THE TITLE III CLEAN AIR ACT AMENDMENT COMPOUNDS

Compound	CAS No.	Primary Ion	Secondary Ion
Methyl chloride (chloromethane); CH <sub>3</sub> Cl	74-87-3	50	52
Carbonyl sulfide; COS	463-58-1	60	62
Vinyl chloride (chloroethene); C <sub>2</sub> H <sub>3</sub> Cl	75-01-4	62	64
Diazomethane; CH <sub>2</sub> N <sub>2</sub>	334-88-3	42	41
Formaldehyde; CH <sub>2</sub> O	50-00-0	29	30
1,3-Butadiene; C <sub>4</sub> H <sub>6</sub>	106-99-0	39	54
Methyl bromide (bromomethane); CH <sub>3</sub> Br	74-83-9	94	96
Phosgene; CCl <sub>2</sub> O	75-44-5	63	65
Vinyl bromide (bromoethene); C <sub>2</sub> H <sub>3</sub> Br	593-60-2	106	108
Ethylene oxide; C <sub>2</sub> H <sub>4</sub> O	75-21-8	29	44
Ethyl chloride (chloroethane); C <sub>2</sub> H <sub>5</sub> Cl	75-00-3	64	66
Acetaldehyde (ethanal); C <sub>2</sub> H <sub>4</sub> O	75-07-0	44	29, 43
Vinylidene chloride (1,1-dichloroethylene); C <sub>2</sub> H <sub>2</sub> Cl <sub>2</sub>	75-35-4	61	96
Propylene oxide; C <sub>3</sub> H <sub>6</sub> O	75-56-9	58	57
Methyl iodide (iodomethane); CH <sub>3</sub> I	74-88-4	142	127
Methylene chloride; CH <sub>2</sub> Cl <sub>2</sub>	75-09-2	49	84, 86
Methyl isocyanate; C <sub>2</sub> H <sub>3</sub> NO	624-83-9	57	56
Allyl chloride (3-chloropropene); C <sub>3</sub> H <sub>5</sub> Cl	107-05-1	76	41, 78
Carbon disulfide; CS <sub>2</sub>	75-15-0	76	44, 78
Methyl tert-butyl ether; C <sub>5</sub> H <sub>12</sub> O	1634-04-4	73	41, 53
Propionaldehyde; C <sub>2</sub> H <sub>5</sub> CHO	123-38-6	58	29, 57
Ethylidene dichloride (1,1-dichloroethane); C <sub>2</sub> H <sub>4</sub> Cl <sub>2</sub>	75-34-3	63	65, 27
Chloroprene (2-chloro-1,3-butadiene); C <sub>4</sub> H <sub>5</sub> Cl	126-99-8	88	53, 90
Chloromethyl methyl ether; C <sub>2</sub> H <sub>5</sub> ClO	107-30-2	45	29, 49
Acrolein (2-propenal); C <sub>3</sub> H <sub>4</sub> O	107-02-8	56	55
1,2-Epoxybutane (1,2-butylene oxide); C <sub>4</sub> H <sub>8</sub> O	106-88-7	42	41, 72
Chloroform; CHCl <sub>3</sub>	67-66-3	83	85, 47
Ethyleneimine (aziridine); C <sub>2</sub> H <sub>5</sub> N	151-56-4	42	43
1,1-Dimethylhydrazine; C <sub>2</sub> H <sub>8</sub> N <sub>2</sub>	57-14-7	60	45, 59
Hexane; C <sub>6</sub> H <sub>14</sub>	110-54-3	57	41, 43
1,2-Propyleneimine (2-methylaziridine); C <sub>3</sub> H <sub>7</sub> N	75-55-8	56	57, 42
Acrylonitrile (2-propenenitrile); C <sub>3</sub> H <sub>3</sub> N	107-13-1	53	52
Methyl chloroform (1,1,1 trichloroethane); C <sub>2</sub> H <sub>3</sub> Cl <sub>3</sub>	71-55-6	97	99, 61
Methanol; CH <sub>4</sub> O	67-56-1	31	29
Carbon tetrachloride; CCl <sub>4</sub>	56-23-5	117	119
Vinyl acetate; C <sub>4</sub> H <sub>6</sub> O <sub>2</sub>	108-05-4	43	86
Methyl ethyl ketone (2-butanone); C <sub>4</sub> H <sub>8</sub> O	78-93-3	43	72

TABLE 2. (continued)

Compound	CAS No.	Primary Ion	Secondary Ion
Benzene; C <sub>6</sub> H <sub>6</sub>	71-43-2	78	77,50
Acetonitrile (cyanomethane); C <sub>2</sub> H <sub>3</sub> N	75-05-8	41	40
Ethylene dichloride (1,2-dichloroethane); C <sub>2</sub> H <sub>4</sub> Cl <sub>2</sub>	107-06-2	62	64, 27
Triethylamine; C <sub>6</sub> H <sub>15</sub> N	121-44-8	86	58, 101
Methylhydrazine; CH <sub>6</sub> N <sub>2</sub>	60-34-4	46	31, 45
Propylene dichloride (1,2-dichloropropane); C <sub>3</sub> H <sub>6</sub> Cl <sub>2</sub>	78-87-5	63	41, 62
2,2,4-Trimethyl pentane; C <sub>8</sub> H <sub>18</sub>	540-84-1	57	41, 56
1,4-Dioxane (1,4 Diethylene oxide); C <sub>4</sub> H <sub>8</sub> O <sub>2</sub>	123-91-1	88	58
Bis(chloromethyl) ether; C <sub>2</sub> H <sub>4</sub> Cl <sub>2</sub> O	542-88-1	79	49, 81
Ethyl acrylate; C <sub>5</sub> H <sub>8</sub> O <sub>2</sub>	140-88-5	55	73
Methyl methacrylate; C <sub>5</sub> H <sub>8</sub> O <sub>2</sub>	80-62-6	41	69, 100
1,3-Dichloropropene; C <sub>3</sub> H <sub>4</sub> Cl <sub>2</sub> (cis)	542-75-6	75	39, 77
Toluene; C <sub>7</sub> H <sub>8</sub>	108-88-3	91	92
Trichloroethylene; C <sub>2</sub> HCl <sub>3</sub>	79-01-6	130	132, 95
1,1,2-Trichloroethane; C <sub>2</sub> H <sub>3</sub> Cl <sub>3</sub>	79-00-5	97	83, 61
Tetrachloroethylene; C <sub>2</sub> Cl <sub>4</sub>	127-18-4	166	164, 131
Epichlorohydrin (1-chloro-2,3-epoxy propane); C <sub>3</sub> H <sub>5</sub> ClO	106-89-8	57	49, 62
Ethylene dibromide (1,2-dibromoethane); C <sub>2</sub> H <sub>4</sub> Br <sub>2</sub>	106-93-4	107	109
N-Nitroso-N-methylurea; C <sub>2</sub> H <sub>5</sub> N <sub>3</sub> O <sub>2</sub>	684-93-5	60	44, 103
2-Nitropropane; C <sub>3</sub> H <sub>7</sub> NO <sub>2</sub>	79-46-9	43	41
Chlorobenzene; C <sub>6</sub> H <sub>5</sub> Cl	108-90-7	112	77, 114
Ethylbenzene; C <sub>8</sub> H <sub>10</sub>	100-41-4	91	106
Xylenes (isomer & mixtures); C <sub>8</sub> H <sub>10</sub>	1330-20-7	91	106
Styrene; C <sub>8</sub> H <sub>8</sub>	100-42-5	104	78, 103
p-Xylene; C <sub>8</sub> H <sub>10</sub>	106-42-3	91	106
m-Xylene; C <sub>8</sub> H <sub>10</sub>	108-38-3	91	106
Methyl isobutyl ketone (hexone); C <sub>6</sub> H <sub>12</sub> O	108-10-1	43	58, 100
Bromoform (tribromomethane); CHBr <sub>3</sub>	75-25-2	173	171, 175
1,1,2,2-Tetrachloroethane; C <sub>2</sub> H <sub>2</sub> Cl <sub>4</sub>	79-34-5	83	85
o-Xylene; C <sub>8</sub> H <sub>10</sub>	95-47-6	91	106
Dimethylcarbonyl chloride; C <sub>3</sub> H <sub>6</sub> ClNO	79-44-7	72	107
N-Nitrosodimethylamine; C <sub>2</sub> H <sub>6</sub> N <sub>2</sub> O	62-75-9	74	42
Beta-Propiolactone; C <sub>3</sub> H <sub>4</sub> O <sub>2</sub>	57-57-8	42	43
Cumene (isopropylbenzene); C <sub>9</sub> H <sub>12</sub>	98-82-8	105	120
Acrylic acid; C <sub>3</sub> H <sub>4</sub> O <sub>2</sub>	79-10-7	72	45, 55
N,N-Dimethylformamide; C <sub>3</sub> H <sub>7</sub> NO	68-12-2	73	42, 44
1,3-Propane sultone; C <sub>3</sub> H <sub>6</sub> O <sub>3</sub> S	1120-71-4	58	65, 122

TABLE 2. (continued)

Compound	CAS No.	Primary Ion	Secondary Ion
Acetophenone; C <sub>8</sub> H <sub>8</sub> O	98-86-2	105	77,120
Dimethyl sulfate; C <sub>2</sub> H <sub>6</sub> O <sub>4</sub> S	77-78-1	95	66,96
Benzyl chloride (a-chlorotoluene); C <sub>7</sub> H <sub>7</sub> Cl	100-44-7	91	126
1,2-Dibromo-3-chloropropane; C <sub>3</sub> H <sub>5</sub> Br <sub>2</sub> Cl	96-12-8	57	155, 157
Bis(2-Chloroethyl)ether; C <sub>4</sub> H <sub>8</sub> Cl <sub>2</sub> O	111-44-4	93	63, 95
Chloroacetic acid; C <sub>2</sub> H <sub>3</sub> ClO <sub>2</sub>	79-11-8	50	45, 60
Aniline (aminobenzene); C <sub>6</sub> H <sub>7</sub> N	62-53-3	93	66
1,4-Dichlorobenzene (p-); C <sub>6</sub> H <sub>4</sub> Cl <sub>2</sub>	106-46-7	146	148, 111
Ethyl carbamate (urethane); C <sub>3</sub> H <sub>7</sub> NO <sub>2</sub>	51-79-6	31	44, 62
Acrylamide; C <sub>3</sub> H <sub>5</sub> NO	79-06-1	44	55, 71
N,N-Dimethylaniline; C <sub>8</sub> H <sub>11</sub> N	121-69-7	120	77, 121
Hexachloroethane; C <sub>2</sub> Cl <sub>6</sub>	67-72-1	201	199, 203
Hexachlorobutadiene; C <sub>4</sub> Cl <sub>6</sub>	87-68-3	225	227, 223
Isophorone; C <sub>9</sub> H <sub>14</sub> O	78-59-1	82	138
N-Nitrosomorpholine; C <sub>4</sub> H <sub>8</sub> N <sub>2</sub> O <sub>2</sub>	59-89-2	56	86, 116
Styrene oxide; C <sub>8</sub> H <sub>8</sub> O	96-09-3	91	120
Diethyl sulfate; C <sub>4</sub> H <sub>10</sub> O <sub>4</sub> S	64-67-5	45	59, 139
Cresylic acid (cresol isomer mixture); C <sub>7</sub> H <sub>8</sub> O	1319-77-3		
o-Cresol; C <sub>7</sub> H <sub>8</sub> O	95-48-7	108	107
Catechol (o-hydroxyphenol); C <sub>6</sub> H <sub>6</sub> O <sub>2</sub>	120-80-9	110	64
Phenol; C <sub>6</sub> H <sub>6</sub> O	108-95-2	94	66
1,2,4-Trichlorobenzene; C <sub>6</sub> H <sub>3</sub> Cl <sub>3</sub>	120-82-1	180	182, 184
Nitrobenzene; C <sub>6</sub> H <sub>5</sub> NO <sub>2</sub>	98-95-3	77	51, 123

**TABLE 3. REQUIRED BFB KEY IONS AND  
ION ABUNDANCE CRITERIA**

Mass	Ion Abundance Criteria <sup>1</sup>
50	8.0 to 40.0 Percent of m/e 95
75	30.0 to 66.0 Percent of m/e 95
95	Base Peak, 100 Percent Relative Abundance
96	5.0 to 9.0 Percent of m/e 95 (See note)
173	Less than 2.0 Percent of m/e 174
174	50.0 to 120.0 Percent of m/e 95
175	4.0 to 9.0 Percent of m/e 174
176	93.0 to 101.0 Percent of m/e 174
177	5.0 to 9.0 Percent of m/e 176

<sup>1</sup>All ion abundances must be normalized to m/z 95, the nominal base peak, even though the ion abundance of m/z 174 may be up to 120 percent that of m/z 95.

TABLE 4. METHOD DETECTION LIMITS (MDL)<sup>1</sup>

TO-14A List	Lab #1, SCAN	Lab #2, SIM
Benzene	0.34	0.29
Benzyl Chloride	--	--
Carbon tetrachloride	0.42	0.15
Chlorobenzene	0.34	0.02
Chloroform	0.25	0.07
1,3-Dichlorobenzene	0.36	0.07
1,2-Dibromoethane	--	0.05
1,4-Dichlorobenzene	0.70	0.12
1,2-Dichlorobenzene	0.44	--
1,1-Dichloroethane	0.27	0.05
1,2-Dichloroethane	0.24	--
1,1-Dichloroethene	--	0.22
cis-1,2-Dichloroethene	--	0.06
Methylene chloride	1.38	0.84
1,2-Dichloropropane	0.21	--
cis-1,3-Dichloropropene	0.36	--
trans-1,3-Dichloropropene	0.22	--
Ethylbenzene	0.27	0.05
Chloroethane	0.19	--
Trichlorofluoromethane	--	--
1,1,2-Trichloro-1,2,2-trifluoroethane	--	--
1,2-Dichloro-1,1,2,2-tetrafluoroethane	--	--
Dichlorodifluoromethane	--	--
Hexachlorobutadiene	--	--
Bromomethane	0.53	--
Chloromethane	0.40	--
Styrene	1.64	0.06
1,1,2,2-Tetrachloroethane	0.28	0.09
Tetrachloroethene	0.75	0.10
Toluene	0.99	0.20
1,2,4-Trichlorobenzene	--	--
1,1,1-Trichloroethane	0.62	0.21
1,1,2-Trichloroethane	0.50	--
Trichloroethene	0.45	0.07
1,2,4-Trimethylbenzene	--	--
1,3,5-Trimethylbenzene	--	--
Vinyl Chloride	0.33	0.48
m,p-Xylene	0.76	0.08
o-Xylene	0.57	0.28

<sup>1</sup>Method Detection Limits (MDLs) are defined as the product of the standard deviation of seven replicate analyses and the student's "t" test value for 99% confidence. For Lab #2, the MDLs represent an average over four studies. MDLs are for MS/SCAN for Lab #1 and for MS/SIM for Lab #2.

TABLE 5. SUMMARY OF EPA DATA ON REPLICATE PRECISION (RP)  
FROM EPA NETWORK OPERATIONS<sup>1</sup>

Monitoring Compound Identification	EPA's Urban Air Toxics Monitoring Program (UATMP)			EPA's Toxics Air Monitoring Stations (TAMS)		
	%RP	#	ppbv	%RP	#	ppbv
Dichlorodifluoromethane	--		--	13.9	47	0.9
Methylene chloride	16.3	07	4.3	19.4	47	0.6
1,2-Dichloroethane	36.2	31	1.6	--	--	--
1,1,1-Trichloroethane	14.1	44	1.0	10.6	47	2.0
Benzene	12.3	56	1.6	4.4	47	1.5
Trichloroethene	12.8	08	1.3	--	--	--
Toluene	14.7	76	3.1	3.4	47	3.1
Tetrachloroethene	36.2	12	0.8	--	--	--
Chlorobenzene	20.3	21	0.9	--	--	--
Ethylbenzene	14.6	32	0.7	5.4	47	0.5
m-Xylene	14.7	75	4.0	5.3	47	1.5
Styrene	22.8	59 <sup>2</sup>	1.1	8.7	47	0.2 <sup>2</sup>
o-Xylene	--		--	6.0	47	0.5
p-Xylene	--					
1,3-Dichlorobenzene	49.1	06	0.6	--	--	--
1,4-Dichlorobenzene	14.7	14	6.5	--	--	--

<sup>1</sup>Denotes the number of replicate or duplicate analysis used to generate the statistic. The replicate precision is defined as the mean ratio of absolute difference to the average value.

<sup>2</sup>Styrene and o-xylene coelute from the GC column used in UATMP. For the TAMS entries, both values were below detection limits for 18 of 47 replicates and were not included in the calculation.

TABLE 6. AUDIT ACCURACY (AA) VALUES<sup>1</sup> FOR SELECTED  
COMPENDIUM METHOD TO-14A COMPOUNDS

Selected Compounds From TO-14A List	FY-88 TAMS AA(%), N=30	FY-88 UATMP AA(%), N=3
Vinyl chloride	4.6	17.9
Bromomethane	--	6.4
Trichlorofluoromethane	6.4	--
Methylene chloride	8.6	31.4
Chloroform	--	4.2
1,2-Dichloroethane	6.8	11.4
1,1,1-Trichloroethane	18.6	11.3
Benzene	10.3	10.1
Carbon tetrachloride	12.4	9.4
1,2-Dichloropropane	--	6.2
Trichloroethene	8.8	5.2
Toluene	8.3	12.5
Tetrachloroethene	6.2	--
Chlorobenzene	10.5	11.7
Ethylbenzene	12.4	12.4
o-Xylene	16.2	21.2

<sup>1</sup>Audit accuracy is defined as the relative difference between the audit measurement result and its nominal value divided by the nominal value. N denotes the number of audits averaged to obtain the audit accuracy value. Information is not available for other TO-14A compounds because they were not present in the audit materials.



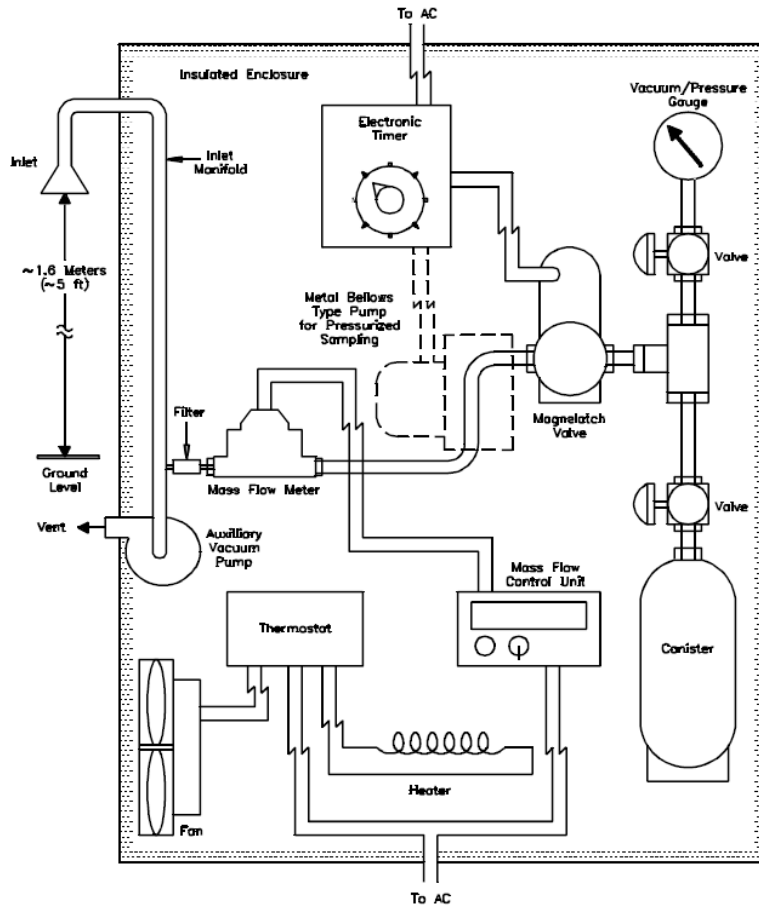
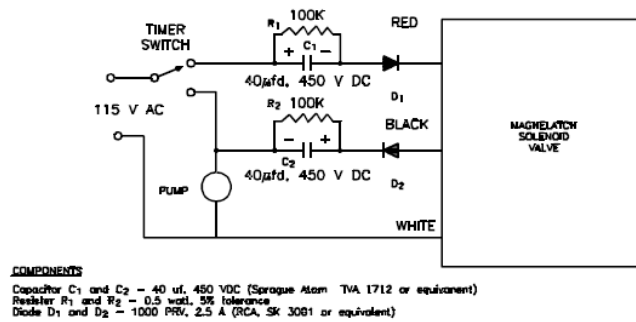
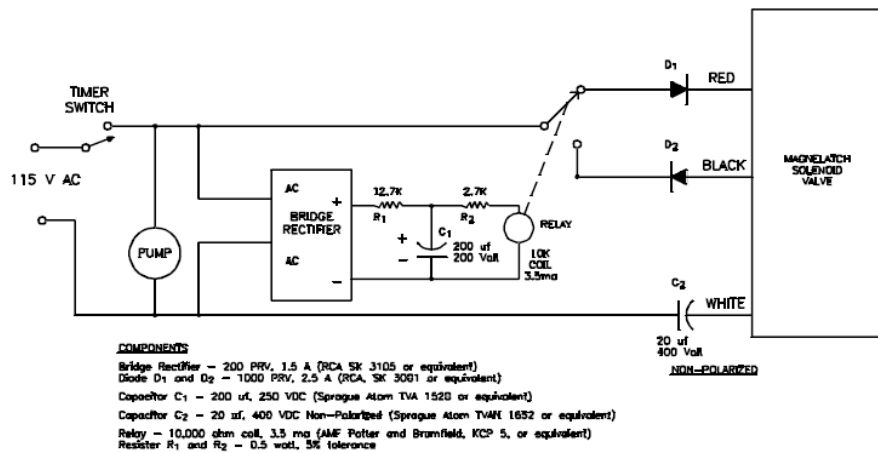

Figure 1. Sampler configuration for subatmospheric pressure or pressurized canister sampling.



(a). Simple Circuit for Operating Magnelatch Valve



(b). Improved Circuit Designed to Handle Power Interruptions

Figure 2. Electrical pulse circuits for driving Skinner magnelatch solenoid valve with mechanical timer.

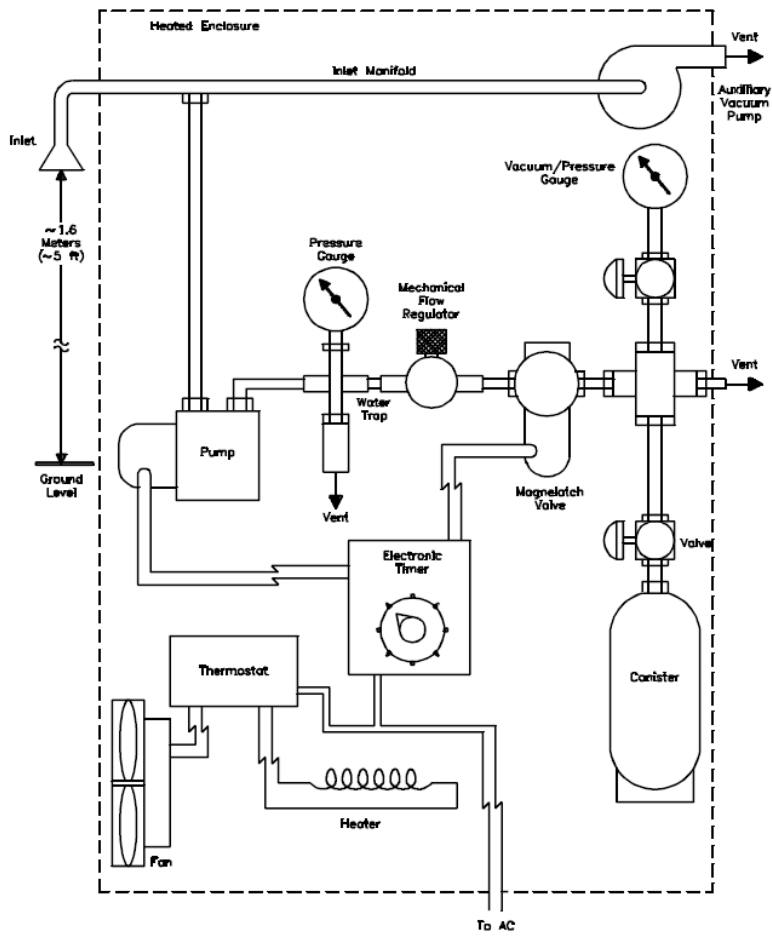

Figure 3. Alternative sampler configuration for pressurized canister sampling.

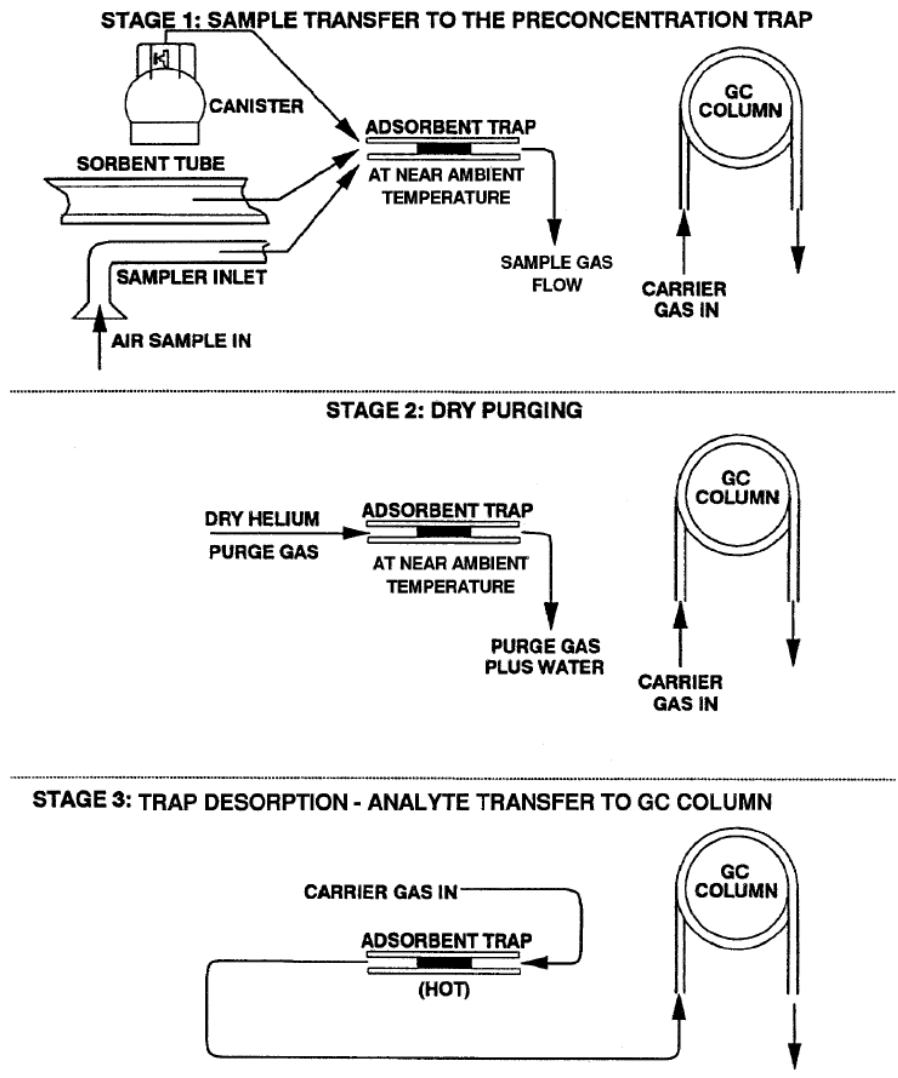

Figure 4. Illustration of three stages of dry purging of adsorbent trap.

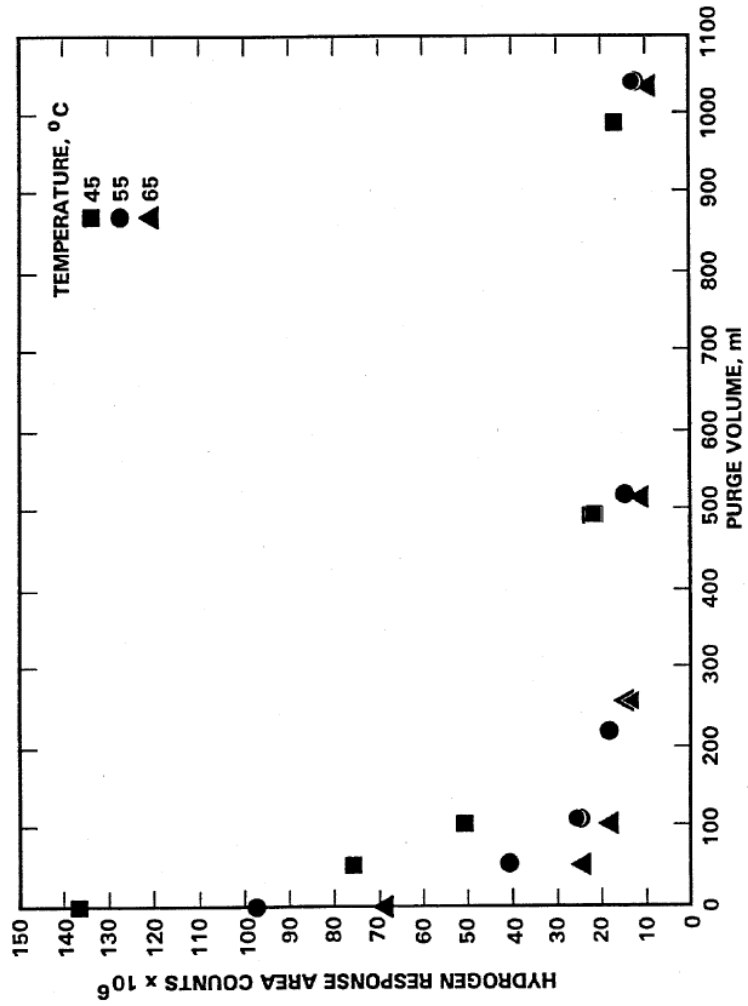

Figure 5. Residual water vapor on VOC concentrator vs. dry He purge volume.

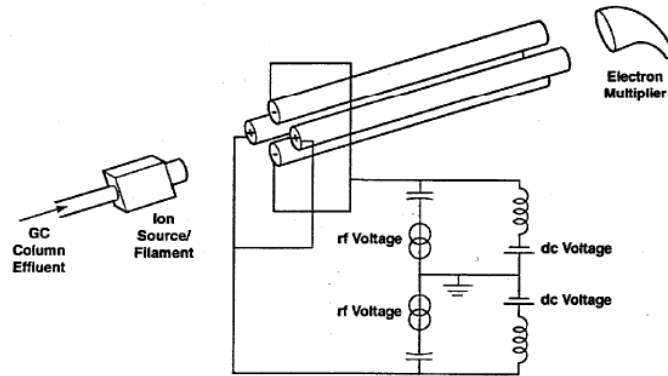

Figure 6. Simplified diagram of a quadrupole mass spectrometer.

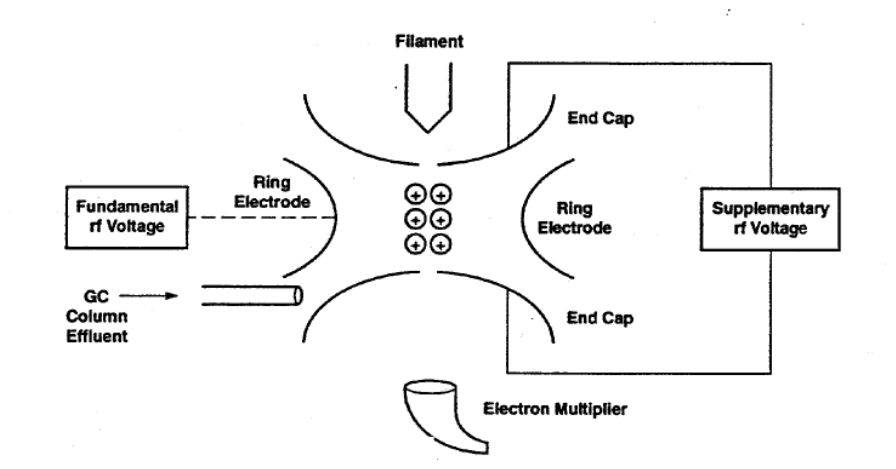

Figure 7. Simplified diagram of an ion trap mass spectrometer.

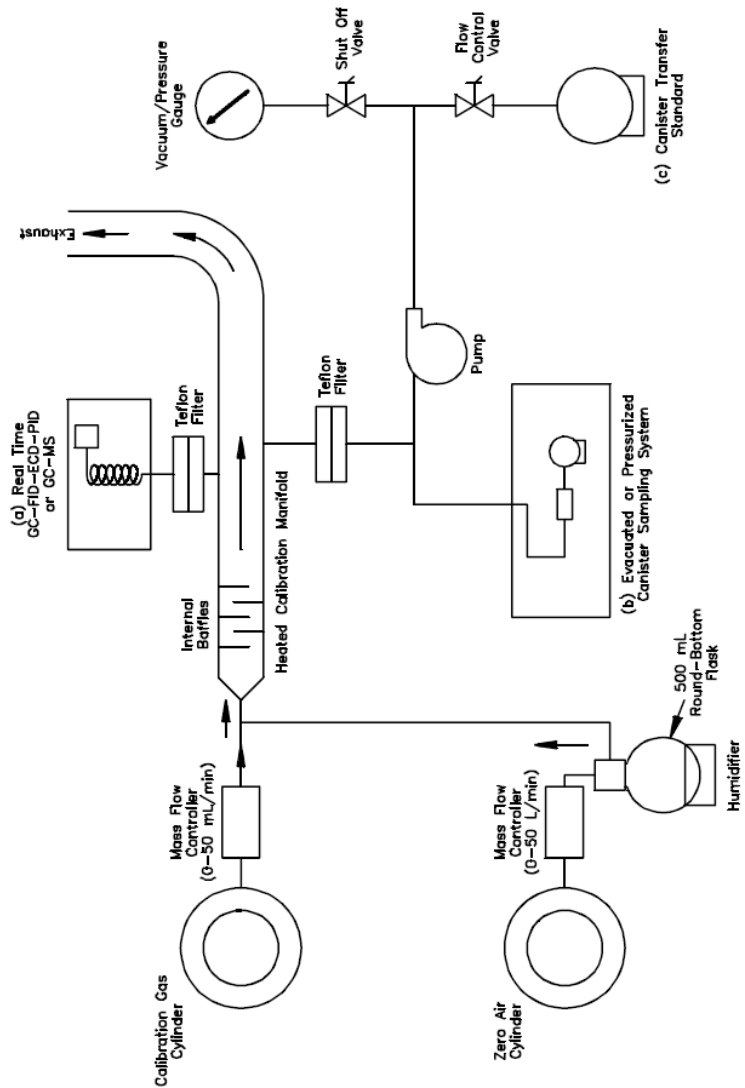

Figure 8. Schematic diagram of calibration system and manifold for (a) analytical system calibration, (b) testing canister sampling system and (c) preparing canister transfer standards.

**COMPENDIUM METHOD TO-15  
CANISTER SAMPLING FIELD TEST DATA SHEET**

**A. GENERAL INFORMATION**

SITE LOCATION: \_\_\_\_\_ SHIPPING DATE: \_\_\_\_\_  
 SITE ADDRESS: \_\_\_\_\_ CANISTER SERIAL NO.: \_\_\_\_\_  
 \_\_\_\_\_ SAMPLER ID: \_\_\_\_\_  
 SAMPLING DATE: \_\_\_\_\_ OPERATOR: \_\_\_\_\_  
 CANISTER LEAK CHECK DATE: \_\_\_\_\_

**B. SAMPLING INFORMATION**

TEMPERATURE					PRESSURE	
	INTERIOR	AMBIENT	MAXIMUM	MINIMUM	CANISTER PRESSURE	
START						
STOP						

SAMPLING TIMES		FLOW RATES			
	LOCAL TIME	ELAPSED TIME METER READING	MANIFOLD FLOW RATE	CANISTER FLOW RATE	FLOW CONTROLLER READOUT
START					
STOP					

SAMPLING SYSTEM CERTIFICATION DATE: \_\_\_\_\_  
 QUARTERLY RECERTIFICATION DATE: \_\_\_\_\_

**C. LABORATORY INFORMATION**

DATA RECEIVED: \_\_\_\_\_  
 RECEIVED BY: \_\_\_\_\_  
 INITIAL PRESSURE: \_\_\_\_\_  
 FINAL PRESSURE: \_\_\_\_\_  
 DILUTION FACTOR: \_\_\_\_\_  
 ANALYSIS  
 GC-FID-ECD DATE: \_\_\_\_\_  
 GC-MSD-SCAN DATE: \_\_\_\_\_  
 GC-MSD-SIM DATE: \_\_\_\_\_  
 RESULTS\*: \_\_\_\_\_  
 \_\_\_\_\_  
 GC-FID-ECD: \_\_\_\_\_  
 GC-MSD-SCAN: \_\_\_\_\_  
 GC-MSD-SIM: \_\_\_\_\_

\_\_\_\_\_  
 SIGNATURE/TITLE

Figure 9. Canister sampling field test data sheet (FTDS).



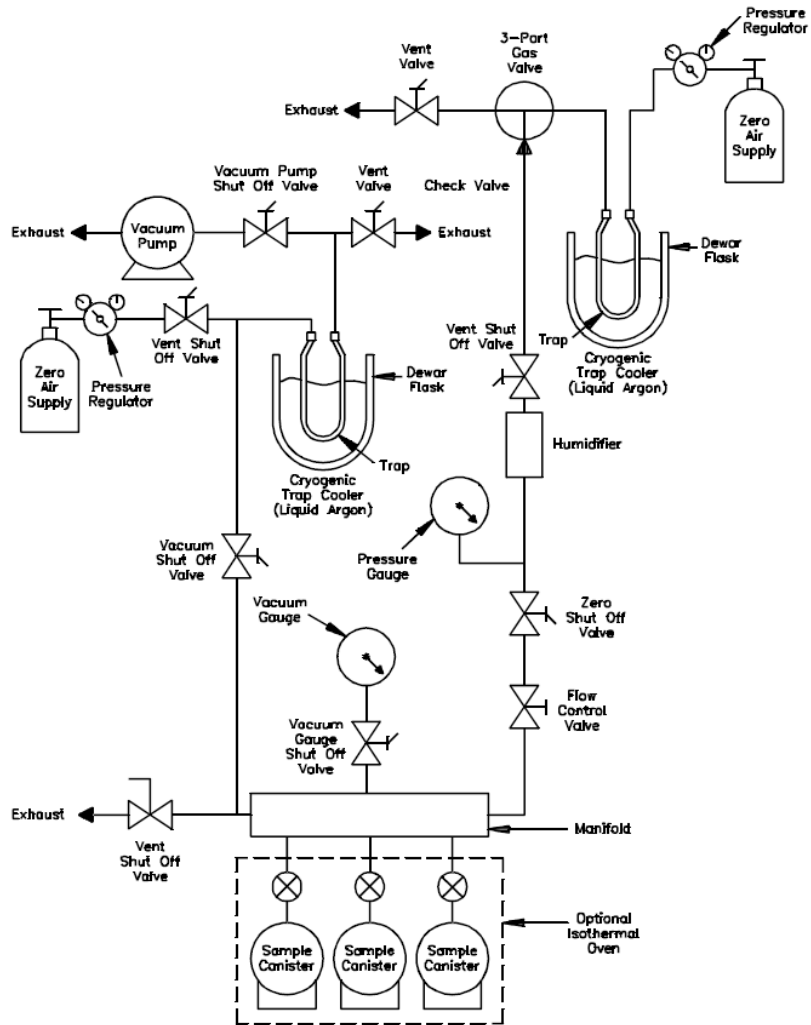

Figure 10. Canister cleaning system.

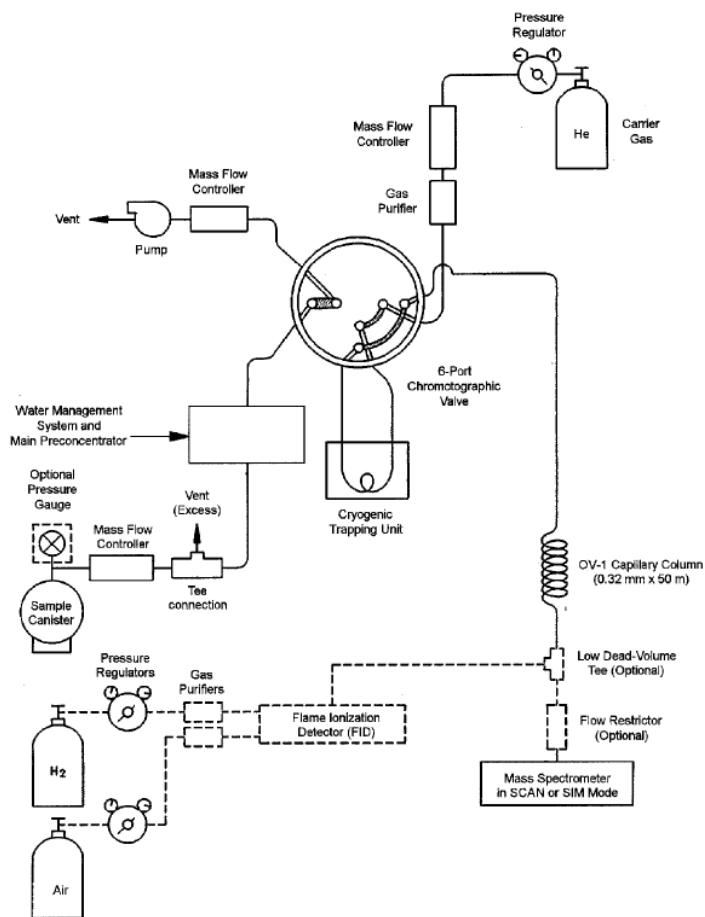
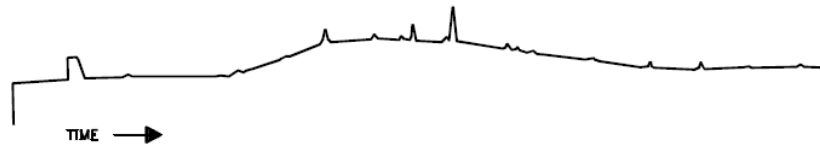
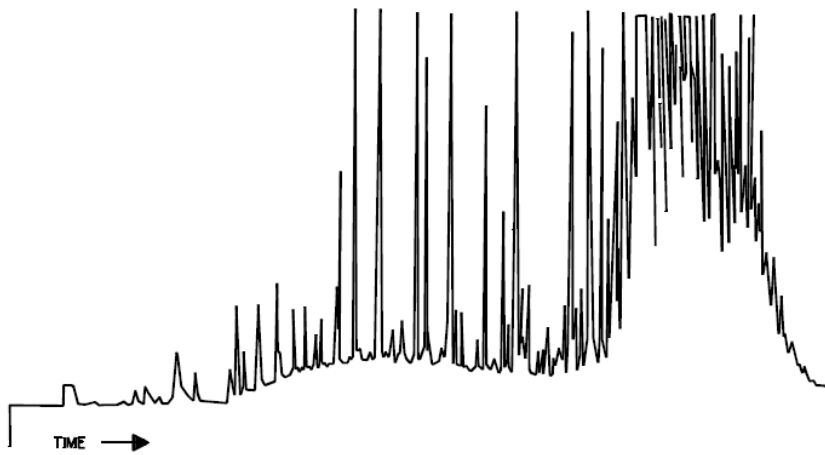

Figure 11. Canister analysis utilizing GC/MS/SCAN/SIM analytical system with optional flame ionization detector with 6-port chromatographic valve in the sample desorption mode.  
 [Alternative analytical system illustrated in Figure 16.]



(a). Certified Sampler



(b). Contaminated Sampler

Figure 12. Example of humid zero air test results for a clean sample canister (a) and a contaminated sample canister (b).

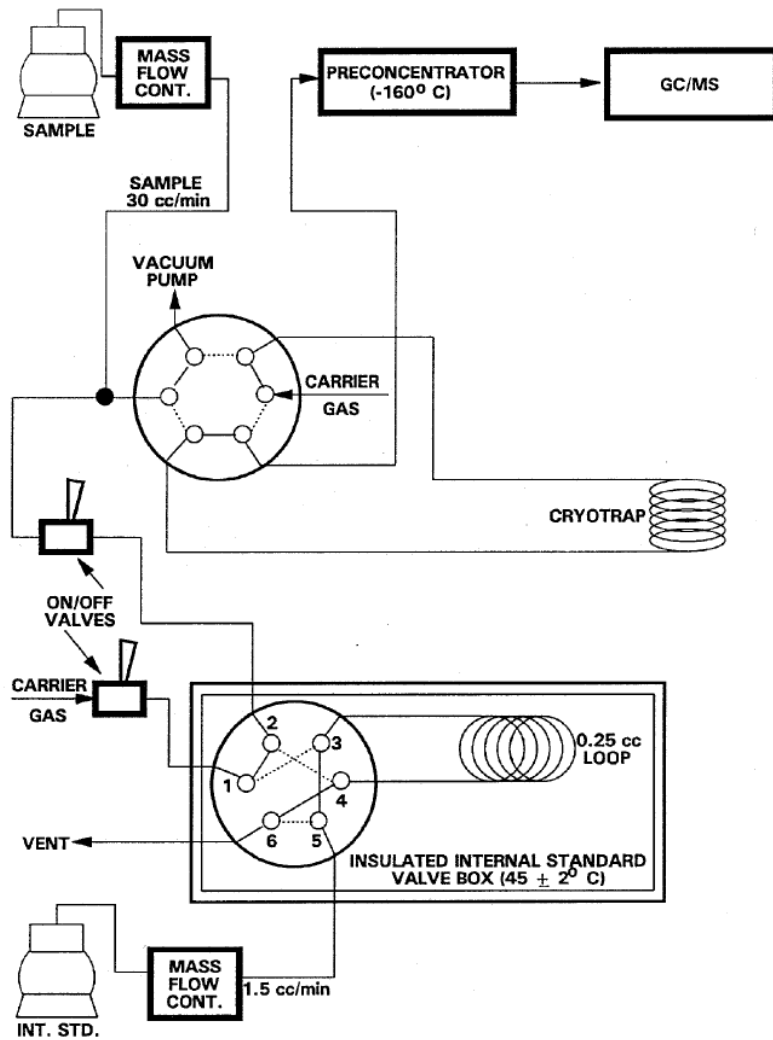

Figure 13. Diagram of design for internal standard addition.

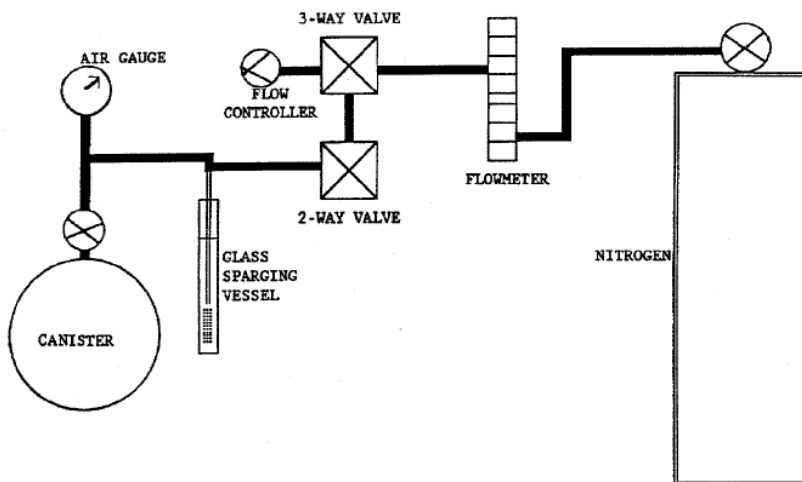

Figure 14. Water method of standard preparation in canisters.

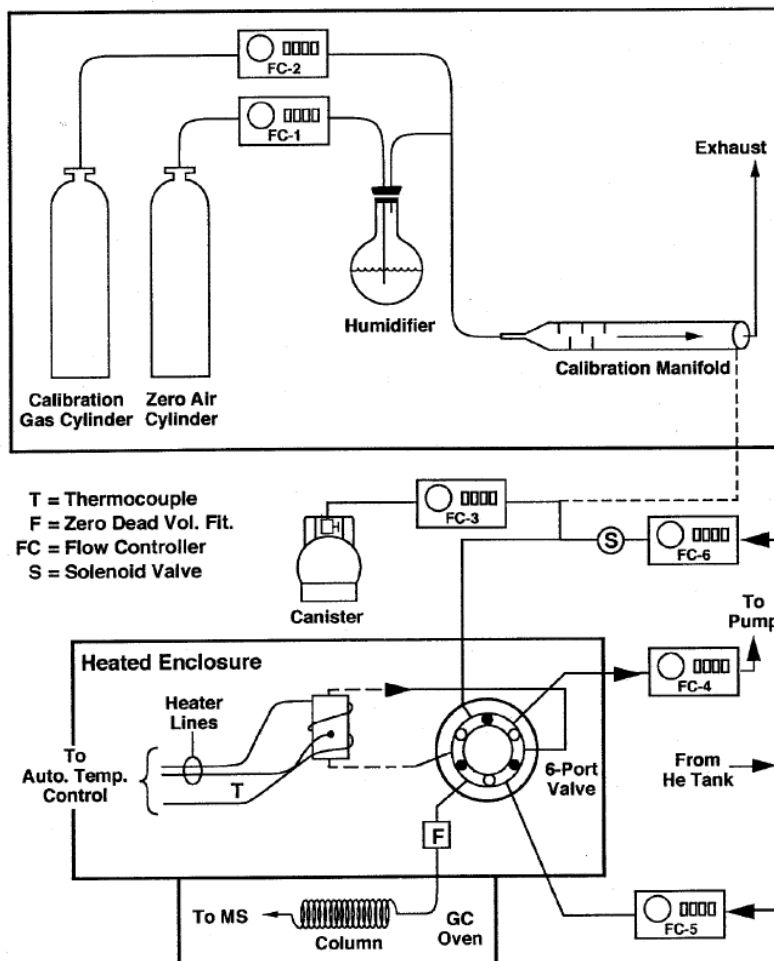

Figure 15. Diagram of the GC/MS analytical system.

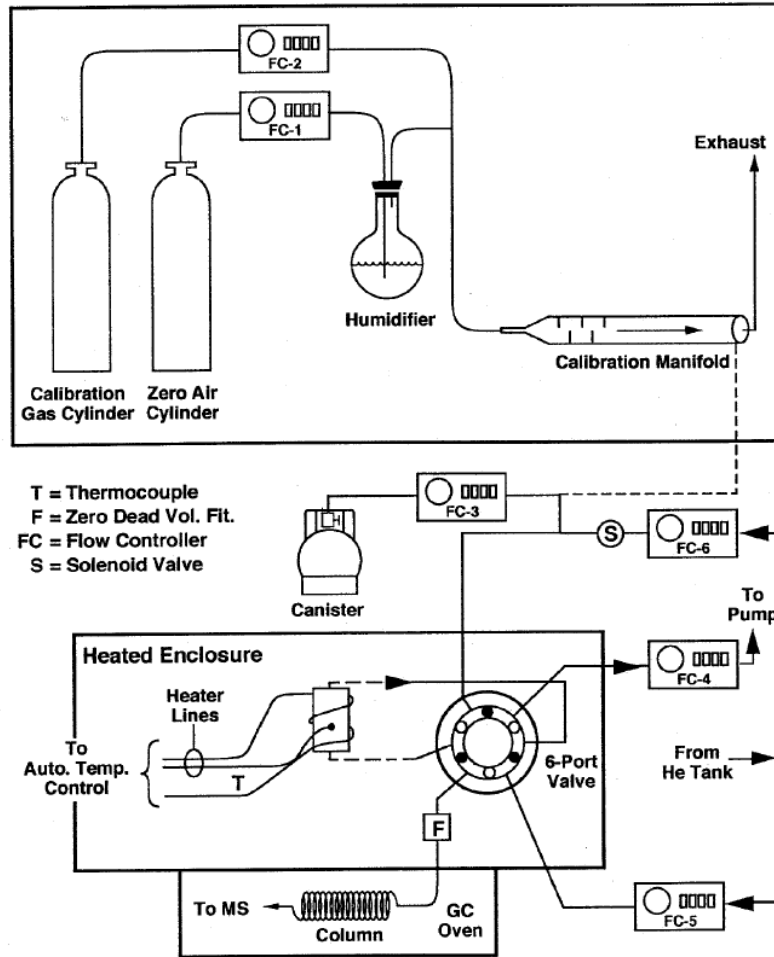

Figure 15. Diagram of the GC/MS analytical system.

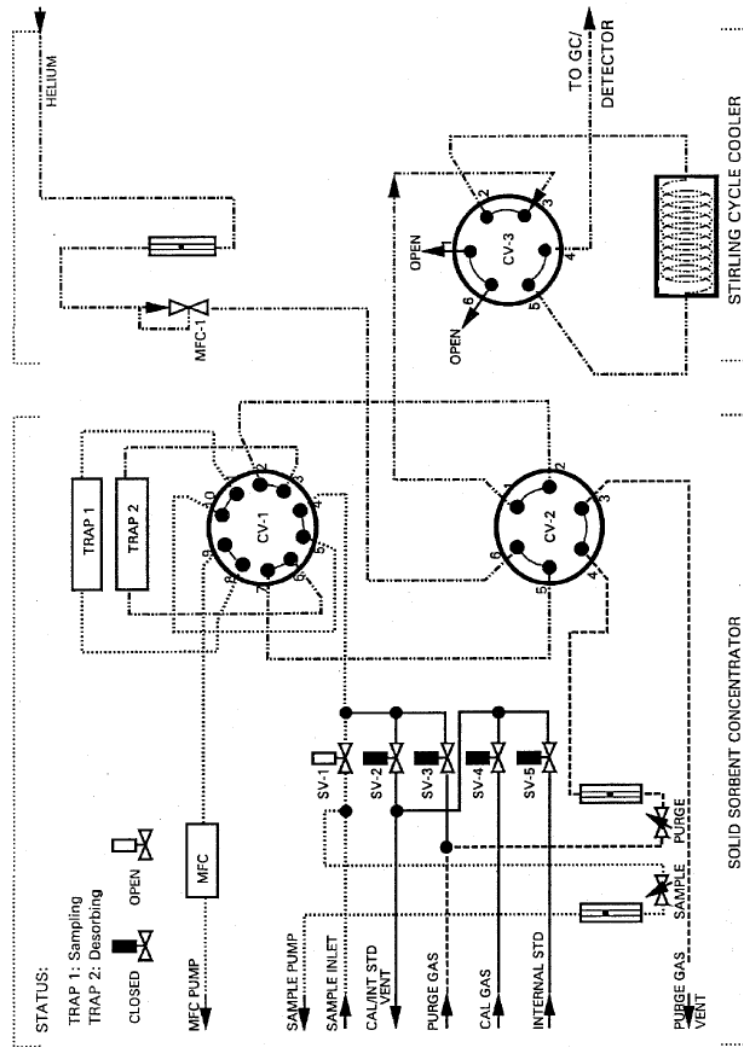

Figure 16. Sample flow diagram of a commercially available concentrator showing the combination of multisorbent tube and cooler (Trap 1 sampling, Trap 2 desorbing).





## **Appendix C**

Appendix C  
Yellowstone Winter Use Air Monitoring 2005  
Aldehydes  
Table 1A

Sample ID: 1X Date: 1/15/2005  
Sample Location: Area Sample Kiosk A  
Sample Length: 321 minutes Sample Volume: 15.4 Liters

Aldehyde	Lab Result ppm	8-Hour TWA ppm	PEL-TWA ppm	TLV ppm	REL-TWA ppm
Acetaldehyde	<0.0077	<0.005	200	25 (STEL)	None
Acrolein	<0.0060	<0.004	0.1	0.1 (STEL)	0.1
Butyraldehyde	<0.0047	<0.003	None	None	None
Formaldehyde	<0.011	<0.008	0.75	0.3 (STEL)	0.016
Heptanal	<0.0030	<0.002	None	None	None
Hexanal	<0.0034	<0.002	None	None	None
iso-valeraldehyde	<0.0039	<0.003	None	None	None
propionaldehyde	<0.0058	<0.004	None	None	None
Valeraldehyde	<0.0039	<0.003	None	None	None

Sample ID: 2G Date: 1/16/2005  
Sample Location: Area Sample Kiosk A  
Sample Length: 341 minutes Sample Volume: 21.7 Liters

Aldehyde	Lab Result ppm	8-Hour TWA ppm	PEL-TWA ppm	TLV ppm	REL-TWA ppm
acetaldehyde	<0.011	<0.007	200	25 (STEL)	None
acrolein	<0.0085	<0.006	0.1	0.1 (STEL)	0.1
butyraldehyde	<0.0066	<0.004	None	None	None
formaldehyde	<0.016	<0.01	0.75	0.3 (STEL)	0.016
heptanal	<0.0042	<0.003	None	None	None
Hexanal	<0.0048	<0.003	None	None	None
iso-valeraldehyde	<0.005	<0.003	None	None	None
Propionaldehyde	<0.0082	<0.005	None	None	None
Valeraldehyde	<0.0055	<0.004	None	None	None

Sample ID: 2XW Date: 1/16/2005  
Location: Area Sample Madison Warming Hut  
Sample Length: 181 minutes Sample Volume: 8.7 Liters

Aldehyde	Lab Result ppm	8-Hour TWA ppm	PEL-TWA ppm	TLV ppm	REL-TWA ppm
Acetaldehyde	<0.0077	<0.005	200	25 (STEL)	None
Acrolein	<0.0060	<0.004	0.1	0.1 (STEL)	0.1
Butyraldehyde	<0.0047	<0.003	None	None	None
Formaldehyde	<0.011	<0.008	0.75	0.3 (STEL)	0.016
Heptanal	<0.0030	<0.002	None	None	None
Hexanal	<0.0034	<0.002	None	None	None
iso-valeraldehyde	<0.0039	<0.003	None	None	None
Propionaldehyde	<0.0058	<0.004	None	None	None
Valeraldehyde	<0.0039	<0.003	None	None	None

Sample ID: MX27      Date: 2/07/2005  
 Location: Area Sample Mammoth Maintenance Shop  
 Sample Length: 194 minutes      Sample Volume: 8.2 Liters

Aldehyde	Lab Result ppm	8-Hour TWA ppm	PEL-TWA ppm	TLV ppm	REL-TWA ppm
Acetaldehyde	<0.020	<0.008	200	25 (STEL)	None
Acrolein	<0.016	<0.006	0.1	0.1 (STEL)	0.1
Butyraldehyde	<0.012	<0.005	None	None	None
Formaldehyde	<0.030	<0.012	0.75	0.3 (STEL)	0.016
Heptanal	<0.0078	<0.003	None	None	None
Hexanal	<0.0089	<0.004	None	None	None
iso-valeraldehyde	<0.0010	<0.0004	None	None	None
Propionaldehyde	<0.015	<0.006	None	None	None
Valeraldehyde	<0.010	<0.0004	None	None	None

Sample ID: 219X      Date: 2/19/2005  
 Location: Area Sample Kiosk A  
 Sample Length: 324 minutes      Sample Volume: 15.3 Liters

Aldehyde	Lab Result ppm	8-Hour TWA ppm	PEL-TWA ppm	TLV ppm	REL-TWA ppm
Acetaldehyde	<0.011	<0.007	200	25 (STEL)	None
Acrolein	<0.0086	<0.006	0.1	0.1 (STEL)	0.1
Butyraldehyde	<0.0066	<0.004	None	None	None
Formaldehyde	<0.016	<0.011	0.75	0.3 (STEL)	0.016
Heptanal	<0.0042	<0.003	None	None	None
Hexanal	<0.0048	<0.003	None	None	None
iso-valeraldehyde	<0.0056	<0.004	None	None	None
Propionaldehyde	<0.0083	<0.006	None	None	None
Valeraldehyde	<0.0056	<0.004	None	None	None

Sample ID: 220X      Date: 2/20/2005  
 Location: Area Sample Kiosk A  
 Sample Length: 342 minutes      Sample Volume: 16.1 Liters

Aldehyde	Lab Result ppm	8-Hour TWA ppm	PEL-TWA ppm	TLV ppm	REL-TWA ppm
Acetaldehyde	<0.010	<0.007	200	25 (STEL)	None
Acrolein	<0.0081	<0.006	0.1	0.1 (STEL)	0.1
Butyraldehyde	<0.0063	<0.004	None	None	None
Formaldehyde	<0.015	<0.011	0.75	0.3 (STEL)	0.016
Heptanal	<0.0040	<0.003	None	None	None
Hexanal	<0.0045	<0.003	None	None	None
iso-valeraldehyde	<0.0053	<0.004	None	None	None
Propionaldehyde	<0.0078	<0.006	None	None	None
Valeraldehyde	<0.0053	<0.004	None	None	None

Table 1B  
Yellowstone Winter Use Air Monitoring 2005  
BETX and Total Petroleum Hydrocarbons (TPH)

Sample ID: 1B                      Date: 1/15/2005  
Location: Personal Sample Kiosk A  
Sample Length: 164 minutes      Sample Volume: 32.6 Liters

<b>BETX and TPH</b>	<b>Lab Result ppm</b>	<b>8-Hour TWA ppm</b>	<b>PEL-TWA ppm</b>	<b>TLV-TWA ppm</b>	<b>REL-TWA ppm</b>
Benzene	<0.0096	<0.003	1.0	0.5	0.1
ethyl benzene	<0.071	<0.024	100	100	100
Toluene	<0.082	<0.028	200	50	100
Xylene	<0.071	<0.024	100	100	100
Total Petroleum Hydrocarbons	<0.19	<0.065	None	None	None

Sample ID: 2BG                      Date: 1/16/2005  
Location: Area Sample Kiosk B  
Sample Length: 341 minutes      Sample Volume: 69.3 Liters

<b>BETX and TPH</b>	<b>Lab Result ppm</b>	<b>8-Hour TWA ppm</b>	<b>PEL-TWA ppm</b>	<b>TLV-TWA ppm</b>	<b>REL-TWA ppm</b>
Benzene	<0.0045	<0.003	1.0	0.5	0.1
ethyl benzene	<0.033	<0.023	100	100	100
Toluene	<0.038	<0.027	200	50	100
Xylene	<0.033	<0.023	100	100	100
Total Petroleum Hydrocarbons	<0.041	<0.029	None	None	None

Sample ID: 2BWH                      Date: 1/16/2005  
Location: Area Sample Madison Warming Hut  
Sample Length: 180 minutes      Sample Volume: 36.1 Liters

<b>BETX and TPH</b>	<b>Lab Result ppm</b>	<b>8-Hour TWA ppm</b>	<b>PEL-TWA ppm</b>	<b>TLV-TWA ppm</b>	<b>REL-TWA ppm</b>
Benzene	<0.0087	<0.003	1.0	0.5	0.1
ethyl benzene	<0.064	<0.024	100	100	100
Toluene	0.73	0.274	200	50	100
Xylene	<0.064	<0.024	100	100	100
Total Petroleum Hydrocarbons	<0.079	<0.030	None	None	None

Sample ID: 3BG                      Date: 1/17/2005  
Location: Area Sample Kiosk A  
Sample Length: 327 minutes      Sample Volume: 63.9 Liters

<b>BETX and TPH</b>	<b>Lab Result ppm</b>	<b>8-Hour TWA ppm</b>	<b>PEL-TWA ppm</b>	<b>TLV-TWA ppm</b>	<b>REL-TWA ppm</b>
Benzene	<0.0049	<0.003	1.0	0.5	0.1
ethyl benzene	<0.036	<0.025	100	100	100
Toluene	<0.042	<0.029	200	50	100
Xylene	<0.036	<0.025	100	100	100
Total Petroleum Hydrocarbons	<0.044	<0.030	None	None	None

Sample ID: M27                      Date: 2/7/2005  
 Location: Personal Sample Mammoth Maintenance Shop  
 Sample Length: 158.4 minutes      Sample Volume: 35.95 Liters

<b>BETX and TPH</b>	<b>Lab Result ppm</b>	<b>8-Hour TWA ppm</b>	<b>PEL-TWA ppm</b>	<b>TLV-TWA ppm</b>	<b>REL-TWA ppm</b>
Benzene	<0.0087	<0.003	1.0	0.5	0.1
ethyl benzene	<0.064	<0.021	100	100	100
Toluene	<0.074	<0.024	200	50	100
Xylene	<0.064	<0.021	100	100	100
Total Petroleum Hydrocarbons	0.11	0.036	None	None	None

Sample ID: 219B                      Date: 2/19/2005  
 Location: Area Sample Kiosk A  
 Sample Length: 313 minutes      Sample Volume: 60.2 Liters

<b>BETX and TPH</b>	<b>Lab Result ppm</b>	<b>8-Hour TWA ppm</b>	<b>PEL-TWA ppm</b>	<b>TLV-TWA ppm</b>	<b>REL-TWA ppm</b>
Benzene	<0.0052	<0.003	1.0	0.5	0.1
ethyl benzene	<0.038	<0.025	100	100	100
Toluene	<0.044	<0.029	200	50	100
Xylene	<0.038	<0.025	100	100	100
Total Petroleum Hydrocarbons	0.21	0.136	None	None	None

Sample ID: 220B                      Date: 2/20/2005  
 Location: Area Sample Kiosk A  
 Sample Length: 343.8 minutes      Sample Volume: 55.1 Liters

<b>BETX and TPH</b>	<b>Lab Result ppm</b>	<b>8-Hour TWA ppm</b>	<b>PEL-TWA ppm</b>	<b>TLV-TWA ppm</b>	<b>REL-TWA ppm</b>
Benzene	<0.0057	<0.004	1.0	0.5	0.1
ethyl benzene	<0.042	<0.030	100	100	100
Toluene	<0.048	<0.034	200	50	100
Xylene	<0.042	<0.030	100	100	100
Total Petroleum Hydrocarbons	0.22	0.158	None	None	None

Sample ID: 222B                      Date: 2/21/2005  
 Location: Personal Sample Kiosk A  
 Sample Length: 344 minutes      Sample Volume: 51 Liters

<b>BETX and TPH</b>	<b>Lab Result ppm</b>	<b>8-Hour TWA ppm</b>	<b>PEL-TWA ppm</b>	<b>TLV-TWA ppm</b>	<b>REL-TWA ppm</b>
Benzene	<0.0061	<0.004	1.0	0.5	0.1
ethyl benzene	<0.045	<0.032	100	100	100
Toluene	<0.052	<0.037	200	50	100
Xylene	<0.045	<0.032	100	100	100
Total Petroleum Hydrocarbons	0.078	0.056	None	None	None

Sample ID: 222B2                      Date: 2/21/2005  
 Location: Area Sample Madison Warming Hut  
 Sample Length: 176 minutes        Sample Volume: 21.4 Liters

<b>BETX and TPH</b>	<b>Lab Result ppm</b>	<b>8-Hour TWA ppm</b>	<b>PEL-TWA ppm</b>	<b>TLV-TWA ppm</b>	<b>REL-TWA ppm</b>
Benzene	<0.015	<0.006	1.0	0.5	0.1
ethyl benzene	<0.11	<0.040	100	100	100
Toluene	<0.12	<0.044	200	50	100
Xylene	<0.11	<0.040	100	100	100
Total Petroleum Hydrocarbons	3.6	1.33	None	None	None

Sample ID: 2226                      Date: 2/21/2005  
 Location: Area Sample Kiosk A  
 Sample Length: 319.3 minutes      Sample Volume: 52.5 Liters

<b>BETX and TPH</b>	<b>Lab Result ppm</b>	<b>8-Hour TWA ppm</b>	<b>PEL-TWA ppm</b>	<b>TLV-TWA ppm</b>	<b>REL-TWA ppm</b>
Benzene	<0.006	<0.004	1.0	0.5	0.1
ethyl benzene	<0.044	<0.029	100	100	100
Toluene	<0.051	<0.034	200	50	100
Xylene	<0.044	<0.029	100	100	100
Total Petroleum Hydrocarbons	0.26	0.17	None	None	None

Table 1C  
Yellowstone Winter Use Air Monitoring 2005  
Elemental and Organic Carbon

Sample ID: 1153                      Date: 1/15/2005  
Location: Personal Sample Kiosk A  
Sample Length: 98 minutes                      Sample Volume: 300.9 Liters

<b>Analyte</b>	<b>Lab Result mg/m<sup>3</sup></b>	<b>8-Hour TWA mg/m<sup>3</sup></b>	<b>PEL- TWA mg/m<sup>3</sup></b>	<b>REL- TWA mg/m<sup>3</sup></b>	<b>TLV-TWA 1996 Proposed mg/m<sup>3</sup></b>	<b>TLV-TWA 2001 Proposed mg/m<sup>3</sup></b>
Organic Carbon	0.045	0.0092	None	None		
Elemental Carbon	<0.0043	<0.0008	None	None		0.02
Total Carbon	0.045	0.0092	None	None	0.15	

Sample ID: 1154                      Date: 1/15/2005  
Location: Personal Sample Kiosk B  
Sample Length: 163 minutes                      Sample Volume: 477.6 Liters

<b>Analyte</b>	<b>Lab Result mg/m<sup>3</sup></b>	<b>8-Hour TWA mg/m<sup>3</sup></b>	<b>PEL- TWA mg/m<sup>3</sup></b>	<b>REL- TWA mg/m<sup>3</sup></b>	<b>TLV-TWA 1996 Proposed mg/m<sup>3</sup></b>	<b>TLV-TWA 2001 Proposed mg/m<sup>3</sup></b>
Organic Carbon	0.043	0.015	None	None		
Elemental Carbon	<0.0027	<0.0009	None	None		0.02
Total Carbon	0.043	0.015	None	None	0.15	

Sample ID: 1163                      Date: 1/16/2005  
Location: Personal Sample Kiosk A  
Sample Length: 327 minutes                      Sample Volume: 1007.2 Liters

<b>Analyte</b>	<b>Lab Result mg/m<sup>3</sup></b>	<b>8-Hour TWA mg/m<sup>3</sup></b>	<b>PEL- TWA mg/m<sup>3</sup></b>	<b>REL- TWA mg/m<sup>3</sup></b>	<b>TLV-TWA 1996 Proposed mg/m<sup>3</sup></b>	<b>TLV-TWA 2001 Proposed mg/m<sup>3</sup></b>
Organic Carbon	0.037	0.025	None	None		
Elemental Carbon	<0.0013	<0.0008	None	None		0.02
Total Carbon	0.037	0.025	None	None	0.15	



Sample ID: 1164 Date: 1/16/2005  
 Location: Area Sample Madison Warming Hut  
 Sample Length: 140 minutes Sample Volume: 413 Liters

Analyte	Lab Result mg/m <sup>3</sup>	8-Hour TWA mg/m <sup>3</sup>	PEL- TWA mg/m <sup>3</sup>	REL- TWA mg/m <sup>3</sup>	TLV-TWA 1996 Proposed mg/m <sup>3</sup>	TLV-TWA 2001 Proposed mg/m <sup>3</sup>
Organic Carbon	0.041	0.012	None	None		
Elemental Carbon	<0.0031	<0.0009	None	None		0.02
Total Carbon	0.041	0.012	None	None	0.15	

Sample ID: 1165 Date: 1/16/2005  
 Location: Personal Sample Kiosk A  
 Sample Length: 286 minutes Sample Volume: 886.6 Liters

Analyte	Lab Result mg/m <sup>3</sup>	8-Hour TWA mg/m <sup>3</sup>	PEL- TWA mg/m <sup>3</sup>	REL- TWA mg/m <sup>3</sup>	TLV-TWA 1996 Proposed mg/m <sup>3</sup>	TLV-TWA 2001 Proposed mg/m <sup>3</sup>
Organic Carbon	0.035	0.021	None	None		
Elemental Carbon	<0.0015	<0.0009	None	None		0.02
Total Carbon	0.035	0.021	None	None	0.15	

Sample ID: 1174 Date: 1/17/2005  
 Location: Area Sample Kiosk A  
 Sample Length: 329 minutes Sample Volume: 954.1 Liters

Analyte	Lab Result mg/m <sup>3</sup>	8-Hour TWA mg/m <sup>3</sup>	PEL- TWA mg/m <sup>3</sup>	REL- TWA mg/m <sup>3</sup>	TLV-TWA 1996 Proposed mg/m <sup>3</sup>	TLV-TWA 2001 Proposed mg/m <sup>3</sup>
Organic Carbon	0.038	0.026	None	None		
Elemental Carbon	<0.0014	<0.0009	None	None		0.02
Total Carbon	0.038	0.026	None	None	0.15	

Sample ID: 1175 Date: 1/17/2005  
 Location: Personal Sample Kiosk A  
 Sample Length: 308 minutes Sample Volume: 954.8 Liters

Analyte	Lab Result mg/m <sup>3</sup>	8-Hour TWA mg/m <sup>3</sup>	PEL- TWA mg/m <sup>3</sup>	REL- TWA mg/m <sup>3</sup>	TLV-TWA 1996 Proposed mg/m <sup>3</sup>	TLV-TWA 2001 Proposed mg/m <sup>3</sup>
Organic Carbon	0.041	0.026	None	None		
Elemental Carbon	<0.0014	<0.0009	None	None		0.02
Total Carbon	0.041	0.026	None	None	0.15	

Sample ID: 272                      Date: 2/07/2005  
 Location: Personal Sample Mammoth Maintenance Shop  
 Sample Length: 187 minutes                      Sample Volume: 466.5 Liters

<b>Analyte</b>	<b>Lab Result mg/m<sup>3</sup></b>	<b>8-Hour TWA mg/m<sup>3</sup></b>	<b>PEL- TWA mg/m<sup>3</sup></b>	<b>REL- TWA mg/m<sup>3</sup></b>	<b>TLV-TWA 1996 Proposed mg/m<sup>3</sup></b>	<b>TLV-TWA 2001 Proposed mg/m<sup>3</sup></b>
Organic Carbon	0.073	0.028	None	None		
Elemental Carbon	0.0044	0.0017	None	None		0.02
Total Carbon	0.078	0.030	None	None	0.15	

Sample ID: 273                      Date: 2/07/2005  
 Location: Personal Sample Mammoth Maintenance Shop  
 Sample Length: 184 minutes                      Sample Volume: 457.24 Liters

<b>Analyte</b>	<b>Lab Result mg/m<sup>3</sup></b>	<b>8-Hour TWA mg/m<sup>3</sup></b>	<b>PEL- TWA mg/m<sup>3</sup></b>	<b>REL- TWA mg/m<sup>3</sup></b>	<b>TLV-TWA 1996 Proposed mg/m<sup>3</sup></b>	<b>TLV-TWA 2001 Proposed mg/m<sup>3</sup></b>
Organic Carbon	0.068	0.026	None	None		
Elemental Carbon	0.0046	0.0018	None	None		0.02
Total Carbon	0.072	0.028	None	None	0.15	

Sample ID: 2192                      Date: 2/19/2005  
 Location: Area Sample Kiosk A  
 Sample Length: 334 minutes                      Sample Volume: 833.1 Liters

<b>Analyte</b>	<b>Lab Result mg/m<sup>3</sup></b>	<b>8-Hour TWA mg/m<sup>3</sup></b>	<b>PEL- TWA mg/m<sup>3</sup></b>	<b>REL- TWA mg/m<sup>3</sup></b>	<b>TLV-TWA 1996 Proposed mg/m<sup>3</sup></b>	<b>TLV-TWA 2001 Proposed mg/m<sup>3</sup></b>
Organic Carbon	0.016	0.011	None	None		
Elemental Carbon	<0.0016	<0.001	None	None		0.02
Total Carbon	0.016	0.011	None	None	0.15	

Sample ID: 2194                      Date: 2/19/2005  
 Location: Personal Sample Kiosk A  
 Sample Length: 336 minutes                      Sample Volume: 830.1 Liters

<b>Analyte</b>	<b>Lab Result mg/m<sup>3</sup></b>	<b>8-Hour TWA mg/m<sup>3</sup></b>	<b>PEL- TWA mg/m<sup>3</sup></b>	<b>REL- TWA mg/m<sup>3</sup></b>	<b>TLV-TWA 1996 Proposed mg/m<sup>3</sup></b>	<b>TLV-TWA 2001 Proposed mg/m<sup>3</sup></b>
Organic Carbon	0.056	0.039	None	None		
Elemental Carbon	<0.0016	<0.0009	None	None		0.02
Total Carbon	0.056	0.001	None	None	0.15	

Sample ID: 2202                      Date: 2/20/2005  
 Location: Area Sample Kiosk A  
 Sample Length: 346 minutes                      Sample Volume: 866 Liters

Analyte	Lab Result mg/m <sup>3</sup>	8-Hour TWA mg/m <sup>3</sup>	PEL- TWA mg/m <sup>3</sup>	REL- TWA mg/m <sup>3</sup>	TLV-TWA 1996 Proposed mg/m <sup>3</sup>	TLV-TWA 2001 Proposed mg/m <sup>3</sup>
Organic Carbon	0.049	0.035	None	None		
Elemental Carbon	<0.0015	<0.0009	None	None		0.02
Total Carbon	0.049	0.001	None	None	0.15	

Sample ID: 2204                      Date: 2/20/2005  
 Location: Personal Sample Kiosk A  
 Sample Length: 349 minutes                      Sample Volume: 895.5 Liters

Analyte	Lab Result mg/m <sup>3</sup>	8-Hour TWA mg/m <sup>3</sup>	PEL- TWA mg/m <sup>3</sup>	REL- TWA mg/m <sup>3</sup>	TLV-TWA 1996 Proposed mg/m <sup>3</sup>	TLV-TWA 2001 Proposed mg/m <sup>3</sup>
Organic Carbon	0.017	0.012	None	None		
Elemental Carbon	<0.0015	<0.001	None	None		0.02
Total Carbon	0.017	0.012	None	None	0.15	

Sample ID: 2222                      Date: 2/21/2005  
 Location: Area Sample Madison Warming Hut  
 Sample Length: 180 minutes                      Sample Volume: 455.4 Liters

Analyte	Lab Result mg/m <sup>3</sup>	8-Hour TWA mg/m <sup>3</sup>	PEL- TWA mg/m <sup>3</sup>	REL- TWA mg/m <sup>3</sup>	TLV-TWA 1996 Proposed mg/m <sup>3</sup>	TLV-TWA 2001 Proposed mg/m <sup>3</sup>
Organic Carbon	0.047	0.018	None	None		
Elemental Carbon	<0.0028	<0.001	None	None		0.02
Total Carbon	0.047	0.018	None	None	0.15	

Sample ID: 2224                      Date: 2/21/2005  
 Location: Personal Sample Kiosk A  
 Sample Length: 346 minutes                      Sample Volume: 863.96 Liters

Analyte	Lab Result mg/m <sup>3</sup>	8-Hour TWA mg/m <sup>3</sup>	PEL- TWA mg/m <sup>3</sup>	REL- TWA mg/m <sup>3</sup>	TLV-TWA 1996 Proposed mg/m <sup>3</sup>	TLV-TWA 2001 Proposed mg/m <sup>3</sup>
Organic Carbon	0.046	0.033	None	None		
Elemental Carbon	<0.0016	<0.001	None	None		0.02
Total Carbon	0.048	0.035	None	None	0.15	

Sample ID: 2225

Date: 2/21/2005

Location: Personal Sample Kiosk A

Sample Length: 343 minutes

Sample Volume: 859.66 Liters

<b>Analyte</b>	<b>Lab Result mg/m<sup>3</sup></b>	<b>8-Hour TWA mg/m<sup>3</sup></b>	<b>PEL- TWA mg/m<sup>3</sup></b>	<b>REL- TWA mg/m<sup>3</sup></b>	<b>TLV-TWA 1996 Proposed mg/m<sup>3</sup></b>	<b>TLV-TWA 2001 Proposed mg/m<sup>3</sup></b>
Organic Carbon	0.047	0.034	None	None		
Elemental Carbon	<0.0015	<0.001	None	None		0.02
Total Carbon	0.047	0.034	None	None	0.15	

Table 1D  
Yellowstone Winter Use Air Monitoring 2005  
Oxides of Nitrogen

Sample ID: 1AN                      Date: 1/15/2005  
Location: Area Sample Kiosk A  
Sample Length: 321 minutes              Sample Volume: 9.49 Liters

<b>NO<sub>x</sub></b>	<b>Lab Result ppm</b>	<b>8-Hour TWA ppm</b>	<b>PEL ppm</b>	<b>TLV-TWA ppm</b>	<b>REL ppm</b>
Nitrogen Dioxide	<0.034	<0.023	5.0 Ceiling	3.0	1.0 STEL
Nitric Oxide			25 TWA	25	25 TWA

Sample ID: 1BN                      Date: 1/15/2005  
Location: Area Sample Kiosk A  
Sample Length: 321 minutes              Sample Volume: 9.49 Liters

<b>NO<sub>x</sub></b>	<b>Lab Result ppm</b>	<b>8-Hour TWA ppm</b>	<b>PEL ppm</b>	<b>TLV-TWA ppm</b>	<b>REL ppm</b>
Nitrogen Dioxide			5.0 Ceiling	3.0	1.0 STEL
Nitric Oxide	<0.034	<0.023	25 TWA	25	25 TWA

Sample ID: 2AN                      Date: 1/16/2005  
Location: Area Sample Kiosk A  
Sample Length: 337 minutes              Sample Volume: 10.38 Liters

<b>NO<sub>x</sub></b>	<b>Lab Result ppm</b>	<b>8-Hour TWA ppm</b>	<b>PEL ppm</b>	<b>TLV-TWA ppm</b>	<b>REL ppm</b>
Nitrogen Dioxide	<0.031	<0.022	5.0 Ceiling	3.0	1.0 STEL
Nitric Oxide			25 TWA	25	25 TWA

Sample ID: 2AW                      Date: 1/16/2005  
Location: Area Madison Warming Hut  
Sample Length: 142 minutes              Sample Volume: 62.03 Liters

<b>NO<sub>x</sub></b>	<b>Lab Result ppm</b>	<b>8-Hour TWA ppm</b>	<b>PEL ppm</b>	<b>TLV-TWA ppm</b>	<b>REL ppm</b>
Nitrogen Dioxide	<0.0051	<0.002	5.0 Ceiling	3.0	1.0 STEL
Nitric Oxide			25 TWA	25	25 TWA

Sample ID: 2BW                      Date: 1/16/2005  
Location: Area Madison Warming Hut  
Sample Length: 142 minutes              Sample Volume: 62.03 Liters

<b>NO<sub>x</sub></b>	<b>Lab Result ppm</b>	<b>8-Hour TWA ppm</b>	<b>PEL ppm</b>	<b>TLV-TWA ppm</b>	<b>REL ppm</b>
Nitrogen Dioxide			5.0 Ceiling	3.0	1.0 STEL
Nitric Oxide	<0.0053	<0.002	25 TWA	25	25 TWA

Sample ID: 3AN                      Date: 1/17/2005  
Location: Area Sample Kiosk A  
Sample Length: 328 minutes              Sample Volume: 10.27 Liters

<b>NO<sub>x</sub></b>	<b>Lab Result ppm</b>	<b>8-Hour TWA ppm</b>	<b>PEL ppm</b>	<b>TLV-TWA ppm</b>	<b>REL ppm</b>
Nitrogen Dioxide	<0.031	<0.021	5.0 Ceiling	3.0	1.0 STEL
Nitric Oxide			25 TWA	25	25 TWA

Sample ID: 3BN Date: 1/17/2005  
 Location: Area Sample Kiosk A  
 Sample Length: 328 minutes Sample Volume: 10.27 Liters

<b>NO<sub>x</sub></b>	<b>Lab Result ppm</b>	<b>8-Hour TWA ppm</b>	<b>PEL ppm</b>	<b>TLV-TWA ppm</b>	<b>REL ppm</b>
Nitrogen Dioxide			5.0 Ceiling	3.0	1.0 STEL
Nitric Oxide	<0.032	<0.022	25 TWA	25	25 TWA

Sample ID: MN27 Date: 2/07/2005  
 Location: Area Sample Mammoth Maintenance Shop  
 Sample Length: 195 minutes Sample Volume: 3.49 Liters

<b>NO<sub>x</sub></b>	<b>Lab Result ppm</b>	<b>8-Hour TWA ppm</b>	<b>PEL ppm</b>	<b>TLV-TWA ppm</b>	<b>REL ppm</b>
Nitrogen Dioxide	<0.091	<0.037	5.0 Ceiling	3.0	1.0 STEL
Nitric Oxide			25 TWA	25	25 TWA

Sample ID: MNX27 Date: 2/07/2005  
 Location: Area Sample Mammoth Maintenance Shop  
 Sample Length: 195 minutes Sample Volume: 3.49 Liters

<b>NO<sub>x</sub></b>	<b>Lab Result ppm</b>	<b>8-Hour TWA ppm</b>	<b>PEL ppm</b>	<b>TLV-TWA ppm</b>	<b>REL ppm</b>
Nitrogen Dioxide			5.0 Ceiling	3.0	1.0 STEL
Nitric Oxide	<0.093	<0.038	25 TWA	25	25 TWA

Sample ID: 219N2 Date: 2/19/2005  
 Location: Area Sample Kiosk A  
 Sample Length: 334 minutes Sample Volume: 13.6 Liters

<b>NO<sub>x</sub></b>	<b>Lab Result ppm</b>	<b>8-Hour TWA ppm</b>	<b>PEL ppm</b>	<b>TLV-TWA ppm</b>	<b>REL ppm</b>
Nitrogen Dioxide	<0.023	<0.016	5.0 Ceiling	3.0	1.0 STEL
Nitric Oxide			25 TWA	25	25 TWA

Sample ID: 219NX Date: 2/19/2005  
 Location: Area Sample Kiosk A  
 Sample Length: 334 minutes Sample Volume: 13.6 Liters

<b>NO<sub>x</sub></b>	<b>Lab Result ppm</b>	<b>8-Hour TWA ppm</b>	<b>PEL ppm</b>	<b>TLV-TWA ppm</b>	<b>REL ppm</b>
Nitrogen Dioxide			5.0 Ceiling	3.0	1.0 STEL
Nitric Oxide	<0.024	<0.017	25 TWA	25	25 TWA

Sample ID: 220N2 Date: 2/20/2005  
 Location: Area Sample Kiosk A  
 Sample Length: 342 minutes Sample Volume: 14 Liters

<b>NO<sub>x</sub></b>	<b>Lab Result ppm</b>	<b>8-Hour TWA ppm</b>	<b>PEL ppm</b>	<b>TLV-TWA ppm</b>	<b>REL ppm</b>
Nitrogen Dioxide	0.97	0.69	5.0 Ceiling	3.0	1.0 STEL
Nitric Oxide			25 TWA	25	25 TWA

Sample ID: 220NX Date: 2/20/2005  
 Location: Area Sample Kiosk A  
 Sample Length: 342 minutes Sample Volume: 14 Liters

<b>NO<sub>x</sub></b>	<b>Lab Result ppm</b>	<b>8-Hour TWA ppm</b>	<b>PEL ppm</b>	<b>TLV-TWA ppm</b>	<b>REL ppm</b>
Nitrogen Dioxide			5.0 Ceiling	3.0	1.0 STEL
Nitric Oxide	<0.023	<0.016	25 TWA	25	25 TWA

Sample ID: 222N2 Date: 2/21/2005  
 Location: Area Sample Kiosk A  
 Sample Length: 338 minutes Sample Volume: 14.2 Liters

<b>NO<sub>x</sub></b>	<b>Lab Result ppm</b>	<b>8-Hour TWA ppm</b>	<b>PEL ppm</b>	<b>TLV-TWA ppm</b>	<b>REL ppm</b>
Nitrogen Dioxide	0.036	0.025	5.0 Ceiling	3.0	1.0 STEL
Nitric Oxide			25 TWA	25	25 TWA

Sample ID: 222NX Date: 2/21/2005  
 Location: Area Sample Kiosk A  
 Sample Length: 338 minutes Sample Volume: 14.2 Liters

<b>NO<sub>x</sub></b>	<b>Lab Result ppm</b>	<b>8-Hour TWA ppm</b>	<b>PEL ppm</b>	<b>TLV-TWA ppm</b>	<b>REL ppm</b>
Nitrogen Dioxide			5.0 Ceiling	3.0	1.0 STEL
Nitric Oxide	<0.023	<0.016	25 TWA	25	25 TWA

Table 1E  
Yellowstone Winter Use Air Monitoring 2005  
Respirable Particulate

Sample ID: 1156      Date: 1/15/2005  
Location: Area Sample Kiosk A  
Sample Length: 311 minutes      Sample Volume: 662.4 Liters

Analyte	Lab Result mg/m <sup>3</sup>	8-Hour TWA mg/m <sup>3</sup>	PEL-TWA mg/m <sup>3</sup>	TLV-TWA mg/m <sup>3</sup>	REL-TWA mg/m <sup>3</sup>
Respirable Particulate	<0.03	<0.019	1.0	0.5	0.1

Sample ID: 1157      Date: 1/15/2005  
Location: Area Sample Kiosk B  
Sample Length: 192 minutes      Sample Volume: 399.4 Liters

Analyte	Lab Result mg/m <sup>3</sup>	8-Hour TWA mg/m <sup>3</sup>	PEL-TWA mg/m <sup>3</sup>	TLV-TWA mg/m <sup>3</sup>	REL-TWA mg/m <sup>3</sup>
Respirable Particulate	<0.05	<0.020	1.0	0.5	0.1

Sample ID: 1166      Date: 1/16/2005  
Location: Personal Sample Kiosk A  
Sample Length: 290 minutes      Sample Volume: 635.1 Liters

Analyte	Lab Result mg/m <sup>3</sup>	8-Hour TWA mg/m <sup>3</sup>	PEL-TWA mg/m <sup>3</sup>	TLV-TWA mg/m <sup>3</sup>	REL-TWA mg/m <sup>3</sup>
Respirable Particulate	<0.03	<0.018	1.0	0.5	0.1

Sample ID: 1167      Date: 1/16/2005  
Location: Area Sample Kiosk A  
Sample Length: 142 minutes      Sample Volume: 303.4 Liters

Analyte	Lab Result mg/m <sup>3</sup>	8-Hour TWA mg/m <sup>3</sup>	PEL-TWA mg/m <sup>3</sup>	TLV-TWA mg/m <sup>3</sup>	REL-TWA mg/m <sup>3</sup>
Respirable Particulate	<0.07	<0.021	1.0	0.5	0.1

Sample ID: 1176      Date: 1/17/2005  
Location: Personal Sample Kiosk A  
Sample Length: 326 minutes      Sample Volume: 712.2 Liters

Analyte	Lab Result mg/m <sup>3</sup>	8-Hour TWA mg/m <sup>3</sup>	PEL-TWA mg/m <sup>3</sup>	TLV-TWA mg/m <sup>3</sup>	REL-TWA mg/m <sup>3</sup>
Respirable Particulate	<0.03	<0.020	1.0	0.5	0.1

Sample ID: 1177      Date: 1/17/2005  
Location: Area Sample Kiosk A  
Sample Length: 325 minutes      Sample Volume: 682.5 Liters

Analyte	Lab Result mg/m <sup>3</sup>	8-Hour TWA mg/m <sup>3</sup>	PEL-TWA mg/m <sup>3</sup>	TLV-TWA mg/m <sup>3</sup>	REL-TWA mg/m <sup>3</sup>
Respirable Particulate	<0.03	<0.020	1.0	0.5	0.1



Sample ID: MG1P8 Date: 2/07/2005  
 Location: Personal Sample Mammoth Maintenance Shop  
 Sample Length: 194 minutes Sample Volume: 486.9 Liters

Analyte	Lab Result mg/m <sup>3</sup>	8-Hour TWA mg/m <sup>3</sup>	PEL-TWA mg/m <sup>3</sup>	TLV-TWA mg/m <sup>3</sup>	REL-TWA mg/m <sup>3</sup>
Respirable Particulate	<0.04	<0.016	1.0	0.5	0.1

Sample ID: MG2P4 Date: 2/07/2005  
 Location: Area Sample Mammoth Maintenance Shop  
 Sample Length: 188 minutes Sample Volume: 473.8 Liters

Analyte	Lab Result mg/m <sup>3</sup>	8-Hour TWA mg/m <sup>3</sup>	PEL-TWA mg/m <sup>3</sup>	TLV-TWA mg/m <sup>3</sup>	REL-TWA mg/m <sup>3</sup>
Respirable Particulate	<0.04	<0.016	1.0	0.5	0.1

Sample ID: 2191 Date: 2/19/2005  
 Location: Area Sample Kiosk A  
 Sample Length: 335 minutes Sample Volume: 832.6 Liters

Analyte	Lab Result mg/m <sup>3</sup>	8-Hour TWA mg/m <sup>3</sup>	PEL-TWA mg/m <sup>3</sup>	TLV-TWA mg/m <sup>3</sup>	REL-TWA mg/m <sup>3</sup>
Respirable Particulate	<0.02	<0.014	1.0	0.5	0.1

Sample ID: 2197 Date: 2/19/2005  
 Location: Personal Sample Kiosk A  
 Sample Length: 313 minutes Sample Volume: 757.9 Liters

Analyte	Lab Result mg/m <sup>3</sup>	8-Hour TWA mg/m <sup>3</sup>	PEL-TWA mg/m <sup>3</sup>	TLV-TWA mg/m <sup>3</sup>	REL-TWA mg/m <sup>3</sup>
Respirable Particulate	<0.03	<0.019	1.0	0.5	0.1

Sample ID: 2201 Date: 2/20/2005  
 Location: Area Sample Kiosk A  
 Sample Length: 344 minutes Sample Volume: 885.1 Liters

Analyte	Lab Result mg/m <sup>3</sup>	8-Hour TWA mg/m <sup>3</sup>	PEL-TWA mg/m <sup>3</sup>	TLV-TWA mg/m <sup>3</sup>	REL-TWA mg/m <sup>3</sup>
Respirable Particulate	<0.02	<0.014	1.0	0.5	0.1

Sample ID: 2207 Date: 2/20/2005  
 Location: Personal Sample Kiosk A  
 Sample Length: 336 minutes Sample Volume: 845 Liters

Analyte	Lab Result mg/m <sup>3</sup>	8-Hour TWA mg/m <sup>3</sup>	PEL-TWA mg/m <sup>3</sup>	TLV-TWA mg/m <sup>3</sup>	REL-TWA mg/m <sup>3</sup>
Respirable Particulate	<0.02	<0.014	1.0	0.5	0.1

Sample ID: 2227

Date: 2/21/2005

Location: Personal Sample Kiosk A

Sample Length: 339 minutes

Sample Volume: 856 Liters

<b>Analyte</b>	<b>Lab Result mg/m<sup>3</sup></b>	<b>8-Hour TWA mg/m<sup>3</sup></b>	<b>PEL-TWA mg/m<sup>3</sup></b>	<b>TLV-TWA mg/m<sup>3</sup></b>	<b>REL-TWA mg/m<sup>3</sup></b>
Respirable Particulate	<0.02	<0.014	1.0	0.5	0.1

## **Appendix D**



**ANALYTICAL REPORT**

Form ARF-AL  
Page 1 of 2  
Part 1 of 1  
01250516213454RX

Date JAN 25 2005  
Laboratory Group Name 05I-0167-01  
Account No. .07003

Montana Tech  
Attention: Terry Spear  
1300 West Park Street  
Butte, MT 59701

FAX (406) 496-4650  
Telephone (406) 496-4445  
E-mail tspear@mttech.edu

**Sampling Collection and Shipment**

Sampling Site \_\_\_\_\_ Date of Collection \_\_\_\_\_  
Date Samples Received at Laboratory January 20, 2005

**Analysis**

Method of Analysis NMAM 6014  
Date(s) of Analysis January 25, 2005

**Analytical Results**

Field Sample Number	Laboratory Number	Sample Type	Nitrogen Dioxide ug/sample	Nitrogen Dioxide MDD	Air Volume L						
1 AN	05I01346	TUBE	ND	<0.034	9.4919						
2 AW	05I01347	TUBE	ND	<0.0051	62.025						
2 AN	05I01348	TUBE	ND	<0.031	10.379						
3 AN	05I01349	TUBE	ND	<0.031	10.266						
118 NO2	05I01350	TUBE	ND	<0.43	0.750						
Reporting Limit			0.6								

| See comment on last page.  
ND Parameter not detected above LOD.  
NR Parameter not requested.  
NA Parameter not applicable.

\*\* See comment on last page.  
( ) Parameter between LOD and LOQ.

*Sarah C. Campbell*  
Analyst: Sarah C. Campbell

*Lisa H. Reid*  
Reviewer: Lisa H. Reid

960 West LeVoy Drive / Salt Lake City, Utah 84123-2547  
Phone (801) 266-7700 Web Page: www.datachem.com  
FAX (801) 268-9992 E-mail: lab@datachem.com



ANALYTICAL REPORT

Form ARF-C  
Page 2 of 2  
01250516213454RX

Date JAN 26 2005  
Laboratory Group Name 05I-0167-01

General Set Comments

ppm formula:  $(24.45 * \text{Result}) / (\text{Volume} * \text{MW})$

General Lab Comments

The results provided in this report relate only to the items tested.  
Samples were received in acceptable condition unless otherwise noted in the General Set Comments above.  
Samples have not been field blank corrected unless otherwise noted in the General Set Comments above.  
This test report shall not be reproduced, except in full, without written approval of DataChem Laboratories, Inc.  
This page is the concluding page of the report.

960 West LeVoy Drive / Salt Lake City, Utah 84123-2547  
Phone (801) 266-7700 Web Page: [www.datachem.com](http://www.datachem.com)  
FAX (801) 268-9992 E-mail: [lab@datachem.com](mailto:lab@datachem.com)



**DATA  
CHEM**  
LABORATORIES, INC.

## ANALYTICAL REQUEST FORM

1.  REGULAR Status OSI 010701  
 RUSH Status Requested - ADDITIONAL CHARGE  
 RESULTS REQUIRED BY \_\_\_\_\_ DATE \_\_\_\_\_  
 CONTACT DATACHEM LABS PRIOR TO SENDING SAMPLES

2. Date 1/10/05 Purchase Order No. \_\_\_\_\_ 4. Quote No. \_\_\_\_\_  
 3. Company Name Montana Tech DCL Project Manager \_\_\_\_\_  
 Address 1300 West Park St  
Butte MT 59701 5. Sample Collection  
 Person to Contact Terry Spear Sampling Site \_\_\_\_\_  
 Telephone (706) 496-4445 Industrial Process \_\_\_\_\_  
 Fax Telephone (706) 496-4650 Date of Collection \_\_\_\_\_  
 E-mail Address TSpear@mttech.edu Time Collected \_\_\_\_\_  
 Billing Address (if different from above) Date of Shipment \_\_\_\_\_  
 Chain of Custody No \_\_\_\_\_

### 6. REQUEST FOR ANALYSES

Laboratory Use Only	Client Sample Number	Matrix*	Sample Volume	ANALYSES REQUESTED - Use method number if known	Units**
<u>OSI 01344</u>	<u>1 AM</u>	<u>Mol. sieve</u>	<u>9491.9 mL</u>	<u>NO2 Method 6014</u>	
	<u>1 BN</u>	<u>Mol. Sieve</u>	<u>9491.9 mL</u>	<u>NO Method 6014</u>	
	<u>1 B</u>	<u>charcoal</u>	<u>32554 mL</u>	<u>Method 1501</u>	
	<u>1 X</u>	<u>XAD-2</u>	<u>16375.9 mL</u>	<u>Method 2539 Issue 2</u>	
<u>( 47</u>	<u>2 AW</u>	<u>Mol. sieve</u>	<u>62025 mL</u>	<u>NO2 Method 6014</u>	
	<u>2 BW</u>	<u>Mol. sieve</u>	<u>62025 mL</u>	<u>NO Method 6014</u>	
<u>↓ 48</u>	<u>2 AM</u>	<u>Mol. Sieve</u>	<u>10379 mL</u>	<u>NO2 Method 6014 (no flow rate)</u>	<u>8 - Bulk air collection</u>
	<u>2 BWH</u>	<u>charcoal</u>	<u>36108 mL</u>	<u>Method 1501</u>	
	<u>2 BG</u>	<u>charcoal</u>	<u>69325 mL</u>	<u>Method 1501</u>	
	<u>2 G</u>	<u>XAD-2</u>	<u>21687 mL</u>	<u>Method 2539 Issue 2</u>	
	<u>2 XW</u>	<u>XAD-2</u>	<u>8712 mL</u>	<u>Method 2539 Issue 2</u>	

\* Specify: Solid sorbent tube, e.g. Charcoal; Filter type; Impinger solution; Bulk sample; Blood; Urine; Tissue; Soil; Water; Other  
 \*\* 1 ug/sample 2 mg/m<sup>3</sup> 3 ppm 4 % 5 \_\_\_\_\_ (other) Please indicate one or more units in the column entitled Units\*\*

Comments \_\_\_\_\_

Possible Contamination and/or Chemical Hazards \_\_\_\_\_

### 7. Chain of Custody (Optional)

Relinquished by _____	Date/Time _____
Received by <u>Rand Pott</u>	Date/Time <u>1/20</u>
Relinquished by <u>Rand Pott</u>	Date/Time <u>1/20</u>
Received by _____	Date/Time _____
Relinquished by _____	Date/Time _____
Received by _____	Date/Time _____

960 West LeVoy Drive / Salt Lake City, UT 84123 800-356-9135 or 801-266-7700 / FAX: 801-268-9992  
 DATACHEM LABORATORIES, INC. www.datachem.com



**DATA  
CHEM**  
LABORATORIES, INC.

## ANALYTICAL REQUEST FORM

1.  REGULAR Status DEI 0107 01  
 RUSH Status Requested - ADDITIONAL CHARGE  
 RESULTS REQUIRED BY \_\_\_\_\_ DATE \_\_\_\_\_  
 CONTACT DATACHEM LABS PRIOR TO SENDING SAMPLES

2. Date 1/18/05 Purchase Order No. \_\_\_\_\_ 4. Quote No. \_\_\_\_\_  
 3. Company Name Maxima Tech DCL Project Manager \_\_\_\_\_  
 Address 1300 West Davis St  
Butte MT 59701 5. Sample Collection  
 Person to Contact Terry Spear Sampling Site \_\_\_\_\_  
 Telephone (406) 496-4445 Industrial Process \_\_\_\_\_  
 Fax Telephone (406) 496-4650 Date of Collection \_\_\_\_\_  
 E-mail Address T.Spear@maxtech.edu Time Collected \_\_\_\_\_  
 Billing Address (if different from above) Date of Shipment \_\_\_\_\_  
 Chain of Custody No. \_\_\_\_\_

### 6. REQUEST FOR ANALYSES

Laboratory Use Only	Client Sample Number	Matrix*	Sample Volume	ANALYSES REQUESTED - Use method number if known	Units**
<u>DEI DL349</u>	<u>3 AM</u>	<u>Mol Sieve</u>	<u>102.66 mL</u>	<u>NO2 Method 6014</u>	
	<u>3 BN</u>	<u>Mol Sieve</u>	<u>102.66 mL</u>	<u>NO Method 6014</u>	
	<u>3 BG</u>	<u>Charcoal</u>	<u>6389.6 mL</u>	<u>Method 1501 OETK+TH</u>	
	<u>3 XG</u>	<u>XAD-2</u>	<u>19914 mL</u>	<u>Method 2539 aldehydes</u>	
	<u>1174</u>	<u>Quartz</u>	<u>954.1 L</u>	<u>EC/OC Method 5040</u>	
	<u>1153</u>	<u>Quartz</u>	<u>300.9 L</u>	<u>EC/OC Method 5040</u>	
	<u>1154</u>	<u>Quartz</u>	<u>888.6 L</u>	<u>EC/OC Method 5040</u>	
	<u>1163</u>	<u>Quartz</u>	<u>1007.2 L</u>	<u>EC/OC Method 5040</u>	
	<u>1164</u>	<u>Quartz</u>	<u>413.0 L</u>	<u>EC/OC Method 5040</u>	
	<u>1165</u>	<u>Quartz</u>	<u>886.6 L</u>	<u>EC/OC Method 5040</u>	
	<u>1175</u>	<u>Quartz</u>	<u>954.8 L</u>	<u>EC/OC Method 5040</u>	

\* Specify: Solid sorbent tube, e.g. Charcoal; Filter type; Impinger solution; Bulk sample; Blood; Urine; Tissue; Soil; Water; Other  
 \*\* 1 ug/sample 2 mg/m<sup>3</sup> 3 ppm 4 % 5 \_\_\_\_\_ (other) Please indicate one or more units in the column entitled Units\*\*

Comments \_\_\_\_\_

Possible Contamination and/or Chemical Hazards \_\_\_\_\_

### 7. Chain of Custody (Optional)

Relinquished by _____	Date/Time _____
Received by <u>Russ Patten</u>	Date/Time <u>1/20</u>
Relinquished by <u>Russ Patten</u>	Date/Time <u>1/20</u>
Received by _____	Date/Time _____
Relinquished by _____	Date/Time _____
Received by _____	Date/Time _____

960 West LeVoy Drive / Salt Lake City, UT 84123  
 DATACHEM LABORATORIES, INC.

800-356-9135 or 801-266-7700 / FAX: 801-268-9992  
 www.datachem.com



**DATA  
CHEM**  
LABORATORIES, INC.

### ANALYTICAL REQUEST FORM

1.  REGULAR Status *OSI-D107-01*  
 RUSH Status Requested - ADDITIONAL CHARGE  
 RESULTS REQUIRED BY \_\_\_\_\_ DATE \_\_\_\_\_  
 CONTACT DATACHEM LABS PRIOR TO SENDING SAMPLES

2. Date *1/12/05* Purchase Order No. \_\_\_\_\_ 4. Quote No. \_\_\_\_\_  
 3. Company Name *MonTech* DCL Project Manager \_\_\_\_\_  
 Address *1300 West Park St*  
*Ann Arbor MI 48101* 5. Sample Collection  
 Person to Contact *Terry Spear* Sampling Site \_\_\_\_\_  
 Telephone (4u) *496-4445* Industrial Process \_\_\_\_\_  
 Fax Telephone (4u) *496-4650* Date of Collection \_\_\_\_\_  
 E-mail Address *T.Spear@mtch.edu* Time Collected \_\_\_\_\_  
 Billing Address (if different from above) Date of Shipment \_\_\_\_\_  
 Chain of Custody No. \_\_\_\_\_

6. REQUEST FOR ANALYSES

Laboratory Use Only	Client Sample Number	Matrix*	Sample Volume	ANALYSES REQUESTED - Use method number if known	Units**
	<i>118 BC</i>	<i>Charcoal</i>	<i>1600.0 ML</i>	<i>Method 1501</i>	
	<i>118 X</i>	<i>XAD-2</i>	<i>800.0 ML</i>	<i>Method 2539</i>	
<i>OSI-D1350</i>	<i>118 NO2</i>	<i>Mol. size</i>	<i>750.0 ML</i>	<i>NO2 Method 6014</i>	
	<i>118 NO</i>	<i>Mol. size</i>	<i>850.0 ML</i>	<i>NO Method 6014</i>	
	<i>#1 Mini Com</i>			<i>TO-15 + TPH.</i>	

\* Specify: Solid sorbent tube, e.g. Charcoal; Filter type; Impinger solution; Bulk sample; Blood; Urine; Tissue; Soil; Water; Other  
 \*\* 1 ug/sample 2 mg/m<sup>3</sup> 3 ppm 4 % 5 \_\_\_\_\_ (other) Please indicate one or more units in the column entitled Units\*\*

Comments \_\_\_\_\_

Possible Contamination and/or Chemical Hazards \_\_\_\_\_

7. Chain of Custody (Optional)

Relinquished by _____	Date/Time _____
Received by <i>R. P. [Signature]</i>	Date/Time <i>1/20</i>
Relinquished by <i>R. P. [Signature]</i>	Date/Time <i>1/20</i>
Received by _____	Date/Time _____
Relinquished by _____	Date/Time _____
Received by _____	Date/Time _____

960 West LeVoy Drive / Salt Lake City, UT 84123  
 DATACHEM LABORATORIES, INC.

800-356-9135 or 801-266-7700 / FAX: 801-268-9992  
 www.datachem.com





**ANALYTICAL REPORT**

Form ARF-AL  
Page 1 of 2  
Part 1 of 1  
01250516222067RX

Date JAN 26 2005  
Laboratory Group Name OST-0167-02  
Account No. 07003

Montana Tech  
Attention: Terry Spear  
1300 West Park Street  
Butte, MT 59701

FAX (406) 496-4650  
Telephone (406) 496-4445  
E-mail tspear@mttech.edu

**Sampling Collection and Shipment**

Sampling Site \_\_\_\_\_ Date of Collection \_\_\_\_\_  
Date Samples Received at Laboratory January 20, 2005

**Analysis**

Method of Analysis NMAM 6014  
Date(s) of Analysis January 25, 2005

**Analytical Results**

Field Sample Number	Laboratory Number	Sample Type	Nitric Oxide ug/sample	Nitric Oxide PPM	Air Volume Lit						
1 BN	05I01351	TUBE	ND	<0.034	9.4919						
2 BW	05I01352	TUBE	ND	<0.0053	62.025						
3 BN	05I01353	TUBE	ND	<0.032	10.266						
118 NO	05I01354	TUBE	ND	<0.38	0.850						
Reporting Limit			0.4								

† See comment on last page.  
ND Parameter not detected above LOD.  
NR Parameter not requested.  
NA Parameter not applicable.

\*\* See comment on last page.  
( ) Parameter between LOD and LOQ  
*Sarah C. Campbell*  
Analyst: Sarah C. Campbell  
*Lisa M. Reid*  
Reviewer: Lisa M. Reid

960 West LeVoy Drive / Salt Lake City, Utah 84123-2547  
Phone (801) 266-7700 Web Page: [www.datachem.com](http://www.datachem.com)  
FAX (801) 268-9992 E-mail: [lab@datachem.com](mailto:lab@datachem.com)



ANALYTICAL REPORT

Form ARF-C  
Page 2 of 2  
01250516222067RX

Date JAN 26 2005  
Laboratory Group Name 05I-0167-02

General Set Comments

ppm formula:  $(24.45 * \text{Result}) / (\text{Volume} * \text{MW})$

General Lab Comments

The results provided in this report relate only to the items tested.  
Samples were received in acceptable condition unless otherwise noted in the General Set Comments above.  
Samples have not been field blank corrected unless otherwise noted in the General Set Comments above.  
This test report shall not be reproduced, except in full, without written approval of DataChem Laboratories, Inc.  
This page is the concluding page of the report.

960 West LeVoy Drive / Salt Lake City, Utah 84123-2547  
Phone (801) 266-7700 Web Page: [www.datachem.com](http://www.datachem.com)  
FAX (801) 268-9992 E-mail: [lab@datachem.com](mailto:lab@datachem.com)



**DATA  
CHEM**  
LABORATORIES, INC.

### ANALYTICAL REQUEST FORM

1.  REGULAR Status DSL-01070  
 RUSH Status Requested - ADDITIONAL CHARGE  
 RESULTS REQUIRED BY \_\_\_\_\_ DATE \_\_\_\_\_  
 CONTACT DATACHEM LABS PRIOR TO SENDING SAMPLES

2. Date 1/18/05 Purchase Order No. \_\_\_\_\_ 4. Quote No. \_\_\_\_\_  
 3. Company Name Montana Tech DCL Project Manager \_\_\_\_\_  
 Address 1300 West Park St  
Butte MT 59701 5. Sample Collection  
 Person to Contact Tevvy Spear Sampling Site \_\_\_\_\_  
 Telephone (406) 496-4445 Industrial Process \_\_\_\_\_  
 Fax Telephone (406) 496-4650 Date of Collection \_\_\_\_\_  
 E-mail Address tspear@mttech.edu Time Collected \_\_\_\_\_  
 Billing Address (if different from above) Date of Shipment \_\_\_\_\_  
 Chain of Custody No \_\_\_\_\_

6. REQUEST FOR ANALYSES

Laboratory Use Only	Client Sample Number	Matrix*	Sample Volume	ANALYSES REQUESTED - Use method number if known	Units**
	1 AN	Mol. sieve	949.9 mL	NO <sub>2</sub> Method 6014	
<u>DSL01351</u>	1 BN	Mol. sieve	949.9 mL	NO Method 6014	
	1 B	charcoal	32554 mL	Method 1501	
	1 X	XAD-2	15375.9 mL	Method 2539 Issue 2	
	2 AW	Mol. sieve	62025 mL	NO <sub>2</sub> Method 6014	
<u>52</u>	2 BW	Mol. sieve	62025 mL	NO Method 6014	
	2 AN	Mol. sieve	10379 mL	NO <sub>2</sub> Method 6014 (no filter)	<u>no filter</u>
	2 BVH	charcoal	36108 mL	Method 1501	
	2 BG	charcoal	69325 mL	Method 1501	
	2 G	XAD-2	21687 mL	Method 2539 Issue 2	
	2 XW	XAD-2	8712 mL	Method 2539 Issue 2	

\* Specify: Solid sorbent tube, e.g. Charcoal; Filter type; Impinger solution; Bulk sample; Blood; Urine; Tissue; Soil; Water; Other  
 \*\* 1. ug/sample 2 mg/m<sup>3</sup> 3. ppm 4. % 5. \_\_\_\_\_ (other) Please indicate one or more units in the column entitled Units\*\*

Comments \_\_\_\_\_

Possible Contamination and/or Chemical Hazards \_\_\_\_\_

7. Chain of Custody (Optional)

Relinquished by _____	Date/Time _____
Received by <u>R. Pott</u>	Date/Time <u>1/20</u>
Relinquished by <u>R. Pott</u>	Date/Time <u>1/20</u>
Received by _____	Date/Time _____
Relinquished by _____	Date/Time _____
Received by _____	Date/Time _____

960 West LeVoy Drive / Salt Lake City, UT 84123  
 DATACHEM LABORATORIES, INC.

800-356-9135 or 801-266-7700 / FAX: 801-268-9992  
 www.datachem.com



**DATA  
CHEM**  
LABORATORIES, INC.

### ANALYTICAL REQUEST FORM

1.  REGULAR Status DEI-DN0702  
 RUSH Status Requested - ADDITIONAL CHARGE  
 RESULTS REQUIRED BY \_\_\_\_\_ DATE \_\_\_\_\_  
 CONTACT DATACHEM LABS PRIOR TO SENDING SAMPLES

2. Date 1/18/05 Purchase Order No. \_\_\_\_\_ 4. Quote No. \_\_\_\_\_  
 3. Company Name Montana Tech DCL Project Manager \_\_\_\_\_  
 Address 1300 West DuRoss St  
Butte MT 59701 5. Sample Collection  
 Person to Contact Terry Spear Sampling Site \_\_\_\_\_  
 Telephone (t/w) 496-4445 Industrial Process \_\_\_\_\_  
 Fax Telephone (f/w) 496-4650 Date of Collection \_\_\_\_\_  
 E-mail Address T.Spear@mttech.edu Time Collected \_\_\_\_\_  
 Billing Address (if different from above) Chain of Custody No \_\_\_\_\_

6. REQUEST FOR ANALYSES

Laboratory Use Only	Client Sample Number	Matrix*	Sample Volume	ANALYSES REQUESTED - Use method number if known	Units**
	3 AN	Mil Silica	102.66 mL	NO 2 Method 6014	
<u>DEI01353</u>	3 BN	Mil Silica	102.66 mL	NO Method 6014	
	3 BG	Charcoal	6387.6 mL	Method 1501 DETX+TPH	
	3 XG	XAD-2	19914 mL	Method 2539 aldehydes	
	1174	Quartz	954.1 L	EC/OC Method 5040	
	1153	Quartz	300.9 L	EC/OC Method 5040	
	1154	Quartz	477.6 L	EC/OC Method 5040	
	1163	Quartz	1007.2 L	EC/OC Method 5040	
	1164	Quartz	413.0 L	EC/OC Method 5040	
	1165	Quartz	886.6 L	EC/OC Method 5040	
	1175	Quartz	954.8 L	EC/OC Method 5040	

\* Specify: Solid sorbent tube, e.g. Charcoal; Filter type; Impinger solution; Bulk sample; Blood; Urine; Tissue; Soil; Water; Other  
 \*\* 1 ug/sample 2 mg/m<sup>3</sup> 3 ppm 4 % 5 \_\_\_\_\_ (other) Please indicate one or more units in the column entitled Units\*\*

Comments \_\_\_\_\_

Possible Contamination and/or Chemical Hazards \_\_\_\_\_

7. Chain of Custody (Optional)

Relinquished by _____	Date/Time _____
Received by <u>Russ Patten</u>	Date/Time <u>1/20</u>
Relinquished by <u>Russ Patten</u>	Date/Time <u>1/20</u>
Received by _____	Date/Time _____
Relinquished by _____	Date/Time _____
Received by _____	Date/Time _____

960 West LeVoy Drive / Salt Lake City, UT 84123  
 DATACHEM LABORATORIES, INC.

800-356-9135 or 801-266-7700 / FAX: 801-268-9992  
 www.datachem.com



**DATA  
CHEM**  
LABORATORIES, INC.

## ANALYTICAL REQUEST FORM

1.  REGULAR Status OSE-DMA 02  
 RUSH Status Requested - ADDITIONAL CHARGE  
 RESULTS REQUIRED BY \_\_\_\_\_ DATE \_\_\_\_\_  
 CONTACT DATACHEM LABS PRIOR TO SENDING SAMPLES

2. Date 11/17/05 Purchase Order No. \_\_\_\_\_ 4. Quote No. \_\_\_\_\_  
 3. Company Name Monfau Tech DCL Project Manager \_\_\_\_\_  
 Address 1300 West Park St  
6-Hz HI 59201 5. Sample Collection  
 Person to Contact Terry Spear Sampling Site \_\_\_\_\_  
 Telephone (906) 496-4443 Industrial Process \_\_\_\_\_  
 Fax Telephone (906) 496-4650 Date of Collection \_\_\_\_\_  
 E-mail Address T.Spear@mtch.edu Time Collected \_\_\_\_\_  
 Billing Address (if different from above) Chain of Custody No. \_\_\_\_\_

### 6. REQUEST FOR ANALYSES

Laboratory Use Only	Client Sample Number	Matrix*	Sample Volume	ANALYSES REQUESTED - Use method number if known	Units**
	1188C	Charcoal	1600.0 ML	Method 1501	
	118X	XAD-2	800.0 ML	Method 2519	
	118 NO2	Mol. size	750.0 ML	NO2 Method 6014	
<u>OSE-DMA 02</u>	118 NO	Mol. size	850.0 ML	NO Method 6014	
	#1 Mini Can			TO-15 + TPH.	

\* Specify: Solid sorbent tube, e.g. Charcoal; Filter type; Impinger solution; Bulk sample; Blood; Urine; Tissue; Soil; Water; Other  
 \*\* 1 ug/sample 2 mg/m<sup>3</sup> 3 ppm 4 % 5 \_\_\_\_\_ (other) Please indicate one or more units in the column entitled Units\*\*

Comments \_\_\_\_\_  
 Possible Contamination and/or Chemical Hazards \_\_\_\_\_

### 7. Chain of Custody (Optional)

Relinquished by _____	Date/Time _____
Received by <u>Ronald Potts</u>	Date/Time <u>1/20</u>
Relinquished by <u>Ronald Potts</u>	Date/Time <u>1/20</u>
Received by _____	Date/Time _____
Relinquished by _____	Date/Time _____
Received by _____	Date/Time _____

960 West LeVoy Drive / Salt Lake City, UT 84123  
 DATACHEM LABORATORIES, INC.

800-356-9135 or 801-266-7700 / FAX: 801-268-9992  
 www.datachem.com



ANALYTICAL REPORT

Form ARF-AL  
Page 1 of 2  
Part 1 of 1  
01250510291132RX

Date JAN 26 2005

Laboratory Group Name 05I-0167-04  
Account No. 07003

Montana Tech  
Attention: Terry Spear  
1300 West Park Street  
Butte, MT 59701

FAX (406) 496-4650  
Telephone (406) 496-4445  
E-mail tspear@mttech.edu

Sampling Collection and Shipment

Sampling Site \_\_\_\_\_ Date of Collection \_\_\_\_\_  
Date Samples Received at Laboratory January 20, 2005

Analysis

Method of Analysis NMAM 5040  
Date(s) of Analysis January 24, 2005

Analytical Results

Field Sample Number	Laboratory Number	Sample Type	Organic Carbon µg/sample	Elemental Carbon µg/sample	Total Carbon µg/sample	Organic Carbon mg/m <sup>3</sup>	Elemental Carbon mg/m <sup>3</sup>	Total Carbon mg/m <sup>3</sup>	Air Volume L
1174	05I01360	FILTER	36.	ND	36.	0.038	<0.0014	0.038	954.1
1153	05I01361	FILTER	14.	ND	14.	0.045	<0.0043	0.045	300.9
1150	05I01362	FILTER	20.	ND	20.	0.043	<0.0027	0.043	477.6
1163	05I01363	FILTER	37.	ND	37.	0.037	<0.0013	0.037	1007.2
1160	05I01364	FILTER	17.	ND	17.	0.041	<0.0031	0.041	413.0
1165	05I01365	FILTER	31.	ND	31.	0.035	<0.0015	0.035	886.6
1175	05I01366	FILTER	39.	ND	39.	0.041	<0.0014	0.041	954.8
118 BQ	05I01367	FILTER	ND	ND	ND	<0.0074	<0.0019	<0.0074	700.0
Reporting Limit			5.2	1.3					

† See comment on last page.  
ND Parameter not detected above LOD.  
NR Parameter not requested.  
NA Parameter not applicable.

\*\* See comment on last page.  
( ) Parameter between LOD and LOQ.

*Mei Qi Huang*  
Analyst: Mei Qi Huang  
*Penny A. Foote*  
Reviewer: Penny A. Foote

960 West LeVoy Drive / Salt Lake City, Utah 84123-2547  
Phone (801) 266-7700 Web Page: www.datachem.com  
FAX (801) 268-9992 E-mail: lab@datachem.com



ANALYTICAL REPORT

Form ARF-C  
Page 2 of 2  
01250510291132RX

Date JAN 26 2005  
Laboratory Group Name 05I-0167-04

**General Set Comments**

Method Reference: NIOSH Manual of Analytical Methods (NMAM), fourth ed., 3/15/03

Sample analysis was performed on a representative 1x1.5 cm<sup>2</sup> area of the sample filter. The reported µg/sample values correspond to the entire exposed area of the sample. The µg/sample values assume an even distribution of organic and elemental carbon on the exposed area of the sample filter. The value for the exposed area is either specified by the client or calculated by subtracting 2 mm (the width of the cassette rim) from the edge of the filter.

The reported results have not been blank corrected.

mg/m<sup>3</sup> formula: Result / Volume

**General Lab Comments**

The results provided in this report relate only to the items tested. Samples were received in acceptable condition unless otherwise noted in the General Set Comments above. Samples have not been field blank corrected unless otherwise noted in the General Set Comments above. This test report shall not be reproduced, except in full, without written approval of DataChem Laboratories, Inc. This page is the concluding page of the report.

960 West LeVoy Drive / Salt Lake City, Utah 84123-2547  
Phone (801) 266-7700 Web Page: www.datachem.com  
FAX (801) 268-9992 E-mail: lab@datachem.com



**DATA  
CHEM**  
LABORATORIES, INC.

## ANALYTICAL REQUEST FORM

1.  REGULAR Status TEST ONLY  
 RUSH Status Requested - ADDITIONAL CHARGE  
 RESULTS REQUIRED BY \_\_\_\_\_ DATE \_\_\_\_\_  
 CONTACT DATACHEM LABS PRIOR TO SENDING SAMPLES

2. Date 1/18/05 Purchase Order No. \_\_\_\_\_ 4. Quote No. \_\_\_\_\_  
 3. Company Name Max Fane Tech DCL Project Manager \_\_\_\_\_  
 Address 1300 West Park St  
Butte MT 59701  
 Person to Contact Terry Spear Sampling Site \_\_\_\_\_  
 Telephone (406) 496-4445 Industrial Process \_\_\_\_\_  
 Fax Telephone (406) 496-4650 Date of Collection \_\_\_\_\_  
 E-mail Address T.Spear@maxfane.com Time Collected \_\_\_\_\_  
 Billing Address (if different from above) Date of Shipment \_\_\_\_\_  
 Chain of Custody No \_\_\_\_\_

### 6. REQUEST FOR ANALYSES

Laboratory Use Only	Client Sample Number	Matrix*	Sample Volume	ANALYSES REQUESTED - Use method number if known	Units**
	3 AM	Mel Sieve	102.66 mL	NO <sub>2</sub> Method 6014	
	3 BM	Mel Sieve	102.66 mL	NO Method 6014	
	3 BG	Charcoal	63896 mL	Method 1501 OETK+TPH	
	3 XG	XAD-2	19914 mL	Method 2539 aldehydes	
DESD 3200	1174	Quartz	954.1 L	EC/OC Method 5090	
U1	1153	Quartz	300.9 L	EC/OC Method 5090	
U2	1154	Quartz	388.6 L	EC/OC Method 5090	
U3	1163	Quartz	1607.2 L	EC/OC Method 5090	
U4	1164	Quartz	413.0 L	EC/OC Method 5090	
U5	1165	Quartz	886.6 L	EC/OC Method 5090	
U6	1175	Quartz	954.8 L	EC/OC Method 5090	

\* Specify: Solid sorbent tube, e.g. Charcoal; Filter type; Impinger solution; Bulk sample; Blood; Urine; Tissue; Soil; Water; Other  
 \*\* 1 ug/sample 2 mg/m<sup>3</sup> 3 ppm 4 % 5 \_\_\_\_\_ (other) Please indicate one or more units in the column entitled Units\*\*

Comments \_\_\_\_\_

Possible Contamination and/or Chemical Hazards \_\_\_\_\_

### 7. Chain of Custody (Optional)

Relinquished by _____	Date/Time _____
Received by <u>Ronald Patten</u>	Date/Time <u>1/20</u>
Relinquished by <u>Ronald Patten</u>	Date/Time <u>1/20</u>
Received by <u>Terry Spear</u>	Date/Time <u>01/24/2005</u>
Relinquished by _____	Date/Time _____
Received by _____	Date/Time _____

960 West LeVoy Drive / Salt Lake City, UT 84123  
 DATACHEM LABORATORIES, INC.

800-356-9135 or 801-266-7700 / FAX: 801-268-9992  
 www.datachem.com





**DATA  
CHEM**  
LABORATORIES, INC.

### ANALYTICAL REQUEST FORM

1.  REGULAR Status *DSE 01/27/05*  
 RUSH Status Requested - ADDITIONAL CHARGE  
 RESULTS REQUIRED BY \_\_\_\_\_ DATE \_\_\_\_\_  
 CONTACT DATACHEM LABS PRIOR TO SENDING SAMPLES

2. Date *11/18/05* Purchase Order No. \_\_\_\_\_ 4. Quote No. \_\_\_\_\_  
 3. Company Name *West Montana Tech* DCL Project Manager \_\_\_\_\_  
 Address *1300 West Paul's St.  
Butte MT 59701* 5. Sample Collection  
 Person to Contact *Terry Spear* Sampling Site \_\_\_\_\_  
 Telephone (406) *496-1445* Industrial Process \_\_\_\_\_  
 Fax Telephone (406) *496-4650* Date of Collection \_\_\_\_\_  
 E-mail Address *T.Spear@wmtc.edu* Time Collected \_\_\_\_\_  
 Billing Address (if different from above) Date of Shipment \_\_\_\_\_  
 Chain of Custody No. \_\_\_\_\_

6. REQUEST FOR ANALYSES

Laboratory Use Only	Client Sample Number	Matrix	Sample Volume	ANALYSES REQUESTED - Use method number if known	Units**
	1156	Filter	662.4 L	gravimetric	
	1157	Filter	399.4 L	gravimetric	
	1166	Filter	635.1 L	gravimetric	
	1167	Filter	302.4 L	gravimetric	
	1176	Filter	712.2 L	grav. metric	
	1177	Filter	682.5 L	grav. metric	
	116 G	Miscellaneous		IPM Method TO 15 + TPH	
	116 SM	Miscellaneous		EPA Method TO 15 + TPH	
	117 G	Miscellaneous		EPA Method TO 15 + TPH	
<i>DSE 01/27/05</i>	118 BQ	Quota	700.0 L	FE10C Method 5000	
	118 BG	Filter	400.0 L	gravimetric	

\* Specify: Solid sorbent tube, e.g. Charcoal; Filter type; Impinger solution; Bulk sample; Blood; Urine; Tissue; Soil; Water; Other  
 \*\* 1 ug/sample 2 mg/m<sup>3</sup> 3 ppm 4 % 5 \_\_\_\_\_ (other) Please indicate one or more units in the column entitled Units\*\*

Comments \_\_\_\_\_

Possible Contamination and/or Chemical Hazards \_\_\_\_\_

7. Chain of Custody (Optional)

Relinquished by _____	Date/Time _____
Received by <i>R. L. Pate</i>	Date/Time <i>1/20</i>
Relinquished by <i>R. L. Pate</i>	Date/Time <i>1/20</i>
Received by <i>M. L. St. H.</i>	Date/Time <i>01/24/2005</i>
Relinquished by _____	Date/Time _____
Received by _____	Date/Time _____

960 West LeVoy Drive / Salt Lake City, UT 84123 800-356-9135 or 801-266-7700 / FAX: 801-268-9992  
 DATACHEM LABORATORIES, INC. www.datachem.com



ANALYTICAL REPORT

Form ARF-AL  
Page 1 of 4  
Part 1 of 3  
01270505083537RX

Date JAN 27 2005  
Laboratory Group Name 05I-0167-05  
Account No. 07003

Montana Tech  
Attention: Terry Spear  
1300 West Park Street  
Butte, MT 59701

FAX (406) 496-4650  
Telephone (406) 496-4445  
E-mail tspear@mttech.edu

Sampling Collection and Shipment

Sampling Site \_\_\_\_\_ Date of Collection \_\_\_\_\_  
Date Samples Received at Laboratory January 20, 2005

Analysis

Method of Analysis NMAM 2539, NMAM 2541  
Date(s) of Analysis January 26, 2005

Analytical Results

Field Sample Number	Laboratory Number	Sample Type	Acetaldehyde µg/sample GC/FID	Acrolein µg/sample GC/FID	Butyraldehyde µg/sample GC/FID	Formaldehyde µg/sample GC/FID	Heptanal µg/sample GC/FID	Hexanal µg/sample GC/FID	Iso-Valeraldehyde µg/sample GC/FID	Propionaldehyde µg/sample GC/FID
1 K	05I01368	XAD-2	ND	ND	ND	ND	ND	ND	ND	ND
2 G	05I01369	XAD-2	ND	ND	ND	ND	ND	ND	ND	ND
2 XW	05I01370	XAD-2	ND	ND	ND	ND	ND	ND	ND	ND
3 XG	05I01371	XAD-2	**	**	**	**	**	**	**	**
110 X	05I01372	XAD-2	ND	ND	ND	ND	ND	ND	ND	ND
Reporting Limit			0.3	0.3	0.3	0.3	0.3	0.3	0.3	0.3

† See comment on last page.  
ND Parameter not detected above LOD.  
NR Parameter not requested.  
NA Parameter not applicable.

\*\* See comment on last page.  
( ) Parameter between LOD and LOQ.

Analyst: Fred M. Rajali  
*Fred M. Rajali*  
Reviewer: \_\_\_\_\_

960 West LeVoy Drive / Salt Lake City, Utah 84123-2547  
Phone (801) 266-7700 Web Page: www.datachem.com  
FAX (801) 268-9992 E-mail: lab@datachem.com



ANALYTICAL REPORT

Form ARF-AL  
Page 2 of 4  
Part 2 of 3  
01270505083537RX

Date JAN 27 2005  
Laboratory Group Name 05I-0167-05  
Account No. 07003

Montana Tech  
Attention: Terry Spear  
1300 West Park Street  
Butte, MT 59701

FAX (406) 496-4650  
Telephone (406) 496-4445  
E-mail tspear@mttech.edu

Sampling Collection and Shipment

Sampling Site \_\_\_\_\_ Date of Collection \_\_\_\_\_  
Date Samples Received at Laboratory January 20, 2005

Analysis

Method of Analysis NMAM 2539, NMAM 2541  
Date(s) of Analysis January 26, 2005

Analytical Results

Field Sample Number	Laboratory Number	Sample Type	Valeraldehyde µg/sample GC/FID	Acetaldehyde µg/sample GC/FID	Acrolein µg/sample GC/FID	Butyraldehyde µg/sample GC/FID	Formaldehyde µg/sample GC/FID	Heptanal µg/sample GC/FID	Hexanal µg/sample GC/FID	Iso-Valeraldehyde µg/sample GC/FID
1 X	05I01368	XAD-2	ND	<0.011	<0.0085	<0.0066	<0.016	<0.0042	<0.0048	<0.0055
2 G	05I01369	XAD-2	ND	<0.0077	<0.0060	<0.0047	<0.011	<0.0030	<0.0034	<0.0039
2 XW	05I01370	XAD-2	ND	<0.019	<0.015	<0.012	<0.028	<0.0074	<0.0084	<0.0098
3 XG	05I01371	XAD-2	**	**	**	**	**	**	**	**
110 X	05I01372	XAD-2	ND	<0.21	<0.16	<0.13	<0.31	<0.080	<0.092	<0.11
Reporting Limit			0.3							

\* See comment on last page.      \*\* See comment on last page.  
 ND Parameter not detected above LOD.      ( ) Parameter between LOD and LOQ.  
 NR Parameter not requested.  
 NA Parameter not applicable.

960 West LeVoy Drive / Salt Lake City, Utah 84123-2547  
 Phone (801) 266-7700      Web Page: www.datachem.com  
 FAX (801) 268-9992      E-mail: lab@datachem.com



ANALYTICAL REPORT

Form ARF-AL  
 Page 3 of 4  
 Part 3 of 3  
 01270505083537RX

Date JAN 27 2005  
 Laboratory Group Name 05I-0167-05  
 Account No. 07003

Montana Tech  
 Attention: Terry Spear  
 1300 West Park Street  
 Butte, MT 59701

FAX (406) 496-4650  
 Telephone (406) 496-4445  
 E-mail tspear@mttech.edu

Sampling Collection and Shipment

Sampling Site \_\_\_\_\_ Date of Collection \_\_\_\_\_  
 Date Samples Received at Laboratory January 20, 2005

Analysis

Method of Analysis NMAM 2539, NMAM 2541  
 Date(s) of Analysis January 26, 2005

Analytical Results

Field Sample Number	Laboratory Number	Sample Type	Propionaldehyde ppm SC/FID	Valeraldehyde ppm SC/FID	Air Volume Liters					
1 X	05I01368	XAD-2	<0.0062	<0.0055	15.3759					
2 G	05I01369	XAD-2	<0.0058	<0.0039	21.687					
2 XM	05I01370	XAD-2	<0.014	<0.0098	8.712					
3 XG	05I01371	XAD-2	**	**	19.914					
118 X	05I01372	XAD-2	<0.16	<0.11	0.8					
Reporting Limit										

† See comment on last page.  
 ND Parameter not detected above LOD.  
 NR Parameter not requested.  
 NA Parameter not applicable.  
 \*\* See comment on last page.  
 ( ) Parameter between LOD and LOQ.

960 West LeVoy Drive / Salt Lake City, Utah 84123-2547  
 Phone (801) 266-7700 Web Page: www.datachem.com  
 FAX (801) 268-9992 E-mail: lab@datachem.com



ANALYTICAL REPORT

Form ARE-C  
Page 4 of 4  
01270505083537RX

Date JAN 27 2005  
Laboratory Group Name 05I-0167-05

**General Set Comments**

ppm formula:  $(24.45 * \text{Result}) / (\text{Volume} * \text{MW})$   
The B section of sample 05I01369 was missing when recieved.  
Sample 05I01371 was not on XAD-2 (treated) tube and was not analyzed.

**General Lab Comments**

The results provided in this report relate only to the items tested.  
Samples were received in acceptable condition unless otherwise noted in the General Set Comments above.  
Samples have not been field blank corrected unless otherwise noted in the General Set Comments above.  
This test report shall not be reproduced, except in full, without written approval of DataChem Laboratories, Inc.  
This page is the concluding page of the report.

960 West LeVoy Drive / Salt Lake City, Utah 84123-2547  
Phone (801) 266-7700      Web Page: [www.datachem.com](http://www.datachem.com)  
FAX (801) 268-9992      E-mail: [lab@datachem.com](mailto:lab@datachem.com)



**DATA  
CHEM**  
LABORATORIES, INC.

### ANALYTICAL REQUEST FORM

1.  REGULAR Status DEF-DIA-05  
 RUSH Status Requested - ADDITIONAL CHARGE  
 RESULTS REQUIRED BY \_\_\_\_\_ DATE \_\_\_\_\_  
 CONTACT DATACHEM LABS PRIOR TO SENDING SAMPLES

2. Date 1/18/05 Purchase Order No. \_\_\_\_\_ 4. Quote No. \_\_\_\_\_  
 3. Company Name Montana Tech DCL Project Manager \_\_\_\_\_  
 Address 1300 West Park St  
Butte MT 59701 5. Sample Collection  
 Person to Contact Terry Spear Sampling Site \_\_\_\_\_  
 Telephone (Y66) 496-4445 Industrial Process \_\_\_\_\_  
 Fax Telephone (404) 496-4650 Date of Collection \_\_\_\_\_  
 E-mail Address TSpear@mttech.edu Time Collected \_\_\_\_\_  
 Billing Address (if different from above) Date of Shipment \_\_\_\_\_  
 Chain of Custody No. \_\_\_\_\_

#### 6. REQUEST FOR ANALYSES

Laboratory Use Only	Client Sample Number	Matrix*	Sample Volume	ANALYSES REQUESTED - Use method number if known	Units**
	1AN	Mol. sieve	949.9 mL	NO <sub>2</sub> Method 6014	
	1BN	Mol. Sieve	949.9 mL	NO Method 6014	
	1B	charcoal	3254 mL	Method 1501	
<u>DEF-DIA-05</u>	1X	XAD-2	15375.9 mL	Method 2539 Issue 2	
	2AW	Mol. sieve	62025 mL	NO <sub>2</sub> Method 6014	
	2BW	Mol. sieve	62025 mL	NO Method 6014	
	2AN	Mol. Sieve	10379 mL	NO <sub>2</sub> Method 6014 (no filter tube)	) <u>with air collection</u>
	2BWH	charcoal	36108 mL	Method 1501	
	2BG	charcoal	69325 mL	Method 1501	
	2G	XAD-2	21687 mL	Method 2539 Issue 2	
<u>M TO</u>	2XW	XAD-2	8718 mL	Method 2539 Issue 2	

\* Specify: Solid sorbent tube, e.g. Charcoal; Filter type; Impinger solution; Bulk sample; Blood; Urine; Tissue; Soil; Water; Other  
 \*\* 1. ug/sample 2 mg/m<sup>3</sup> 3 ppm 4 % 5 \_\_\_\_\_ (other) Please indicate one or more units in the column entitled Units\*\*

Comments \_\_\_\_\_

Possible Contamination and/or Chemical Hazards \_\_\_\_\_

#### 7. Chain of Custody (Optional)

Relinquished by _____	Date/Time _____
Received by <u>Rand Pott</u>	Date/Time <u>1/20</u>
Relinquished by <u>Rand Pott</u>	Date/Time <u>1/20</u>
Received by _____	Date/Time _____
Relinquished by _____	Date/Time _____
Received by _____	Date/Time _____

960 West LeVoy Drive / Salt Lake City, UT 84123  
 DATACHEM LABORATORIES, INC.

800-356-9135 or 801-266-7700 / FAX: 801-266-9992  
 www.datachem.com



**DATA  
CHEM**  
LABORATORIES, INC.

## ANALYTICAL REQUEST FORM

1.  REGULAR Status DISE DILETOS  
 RUSH Status Requested - ADDITIONAL CHARGE  
 RESULTS REQUIRED BY \_\_\_\_\_ DATE \_\_\_\_\_  
 CONTACT DATACHEM LABS PRIOR TO SENDING SAMPLES

2. Date 1/18/05 Purchase Order No. \_\_\_\_\_ 4. Quote No. \_\_\_\_\_  
 3. Company Name Maxima Tech DCL Project Manager \_\_\_\_\_  
 Address 1300 West Davis St  
Durham NJ 07901 5. Sample Collection  
 Person to Contact Terry Spear Sampling Site \_\_\_\_\_  
 Telephone (404) 496-4445 Industrial Process \_\_\_\_\_  
 Fax Telephone (404) 496-4650 Date of Collection \_\_\_\_\_  
 E-mail Address T.Spear@maxtech.edu Time Collected \_\_\_\_\_  
 Billing Address (if different from above) Chain of Custody No \_\_\_\_\_

### 6. REQUEST FOR ANALYSES

Laboratory Use Only	Client Sample Number	Matrix*	Sample Volume	ANALYSES REQUESTED - Use method number if known	Units**
	3 AM	Mel. Sieve	102.66 mL	NO <sub>2</sub> Method 6014	
	3 BM	Mel. Sieve	102.66 mL	NO Method 6014	
	3 BG	Charcoal	6387.6 mL	Method 1501 OETX+TPH	
<u>DISE DILETOS</u>	3 XG	XAD-2	1991.4 mL	Method 2539 aldehydes	
	1174	Quartz	954.1 L	IC/OC Method 5040	
	1153	Quartz	300.9 L	IC/OC Method 5040	
	1154	Quartz	388.6 L	IC/OC Method 5040	
	1163	Quartz	1007.2 L	IC/OC Method 5040	
	1164	Quartz	413.0 L	IC/OC Method 5040	
	1165	Quartz	886.6 L	IC/OC Method 5040	
	1175	Quartz	954.8 L	IC/OC Method 5040	

\* Specify: Solid sorbent tube, e.g. Charcoal; Filter type; Impinger solution; Bulk sample; Blood; Urine; Tissue; Soil; Water; Other  
 \*\* 1. ug/sample 2. mg/m<sup>3</sup> 3. ppm 4. % 5. \_\_\_\_\_ (other) Please indicate one or more units in the column entitled Units\*\*

Comments \_\_\_\_\_

Possible Contamination and/or Chemical Hazards \_\_\_\_\_

### 7. Chain of Custody (Optional)

Relinquished by _____	Date/Time _____
Received by <u>Russ Peth</u>	Date/Time <u>1/20</u>
Relinquished by <u>Russ Peth</u>	Date/Time <u>1/20</u>
Received by _____	Date/Time _____
Relinquished by _____	Date/Time _____
Received by _____	Date/Time _____

960 West LeVoy Drive / Salt Lake City, UT 84123  
 DATACHEM LABORATORIES, INC.

800-356-9135 or 801-266-7700 / FAX: 801-268-9992  
 www.datachem.com



**DATA  
CHEM**  
LABORATORIES, INC.

### ANALYTICAL REQUEST FORM

1.  REGULAR Status DSI-012705  
 RUSH Status Requested - ADDITIONAL CHARGE  
 RESULTS REQUIRED BY \_\_\_\_\_ DATE \_\_\_\_\_  
 CONTACT DATACHEM LABS PRIOR TO SENDING SAMPLES

2. Date 11/18/05 Purchase Order No. \_\_\_\_\_ 4. Quote No. \_\_\_\_\_  
 3. Company Name Manufacture Tech DCL Project Manager \_\_\_\_\_  
 Address 1300 West Park St  
K-Itz MI 59201 5. Sample Collection  
 Person to Contact Terry Spear Sampling Site \_\_\_\_\_  
 Telephone (904) 496-4443 Industrial Process \_\_\_\_\_  
 Fax Telephone (904) 496-4650 Date of Collection \_\_\_\_\_  
 E-mail Address T.Spear@mttech.edu Time Collected \_\_\_\_\_  
 Billing Address (if different from above) Date of Shipment \_\_\_\_\_  
 Chain of Custody No. \_\_\_\_\_

**6. REQUEST FOR ANALYSES**

Laboratory Use Only	Client Sample Number	Matrix*	Sample Volume	ANALYSES REQUESTED - Use method number if known	Units**
	118 BC	Charcoal	1000.0 ML	Method 1501	
118B1392	118 X	XAD-2	300.0 ML	Method 2539	
	118 NO2	Mul. size	750.0 ML	NO2 Method 6014	
	118 NO	Mul. size	850.0 ML	NO Method 6014	
	#1 Mini Can			TO-15 + TPH	

\* Specify: Solid sorbent tube, e.g Charcoal; Filter type; Impinger solution; Bulk sample; Blood; Urine; Tissue; Soil; Water; Other  
 \*\* 1. ug/sample 2. mg/m<sup>3</sup> 3. ppm 4. % 5. \_\_\_\_\_ (other) Please indicate one or more units in the column entitled Units\*\*

Comments \_\_\_\_\_

Possible Contamination and/or Chemical Hazards \_\_\_\_\_

**7. Chain of Custody (Optional)**

Relinquished by _____	Date/Time _____
Received by <u>Ronald Potts</u>	Date/Time <u>1/20</u>
Relinquished by <u>Ronald Potts</u>	Date/Time <u>1/20</u>
Received by _____	Date/Time _____
Relinquished by _____	Date/Time _____
Received by _____	Date/Time _____





ANALYTICAL REPORT

Form ARF-AL  
 Page 1 of 2  
 Part 1 of 1  
 01270509192994RX

Date JAN 27 2005  
 Laboratory Group Name OSI-0167-06  
 Account No. 07003

Montana Tech  
 Attention: Terry Spear  
 1300 West Park Street  
 Butte, MT 59701

FAX (406) 496-4650  
 Telephone (406) 496-4445  
 E-mail tspear@mttech.edu

Sampling Collection and Shipment

Sampling Site \_\_\_\_\_ Date of Collection \_\_\_\_\_  
 Date Samples Received at Laboratory January 20, 2005

Analysis

Method of Analysis NMAM 0500  
 Date(s) of Analysis January 27, 2005

Analytical Results

Field Sample Number	Laboratory Number	Sample Type	Total Particulates mg/sample	Total Particulates µg/m <sup>3</sup>	Air Volume liters						
1156	OSI01373	FILTER	ND	<0.03	562.4						
1157	OSI01374	FILTER	ND	<0.05	399.4						
1166	OSI01375	FILTER	ND	<0.03	635.1						
1167	OSI01376	FILTER	ND	<0.07	303.4						
1176	OSI01377	FILTER	ND	<0.03	712.2						
1177	OSI01378	FILTER	ND	<0.03	682.5						
118 BG	OSI01379	FILTER	ND	<0.05	400.0						
Reporting Limit			0.02								

† See comment on last page.  
 ND Parameter not detected above LOD.  
 NR Parameter not requested.  
 NA Parameter not applicable.

\*\* See comment on last page.  
 ( ) Parameter between LOD and LOQ.

*P.P. Steen*  
 Analyst: Peter P. Steen  
*Paul M. Negerdichian*  
 Reviewer: Paul M. Negerdichian

960 West LeVoy Drive / Salt Lake City, Utah 84123-2547  
 Phone (801) 266-7700 Web Page: www.datachem.com  
 FAX (801) 268-9992 E-mail: lab@datachem.com



ANALYTICAL REPORT

Form ARF-C  
Page 2 of 2  
01270509192994RX

Date JAN 27 2005  
Laboratory Group Name Q5I-0167-06

**General Set Comments**

Results are not blank corrected.

**General Lab Comments**

The results provided in this report relate only to the items tested.  
Samples were received in acceptable condition unless otherwise noted in the General Set Comments above.  
Samples have not been field blank corrected unless otherwise noted in the General Set Comments above.  
This test report shall not be reproduced, except in full, without written approval of DataChem Laboratories, Inc.  
This page is the concluding page of the report.

960 West LeVoy Drive / Salt Lake City, Utah 84123-2547  
Phone (801) 266-7700      Web Page: [www.datachem.com](http://www.datachem.com)  
FAX (801) 268-9992      E-mail: [lab@datachem.com](mailto:lab@datachem.com)



**DATA  
CHEM**  
LABORATORIES, INC.

### ANALYTICAL REQUEST FORM

1.  REGULAR Status DSE OILFIELD  
 RUSH Status Requested - ADDITIONAL CHARGE  
 RESULTS REQUIRED BY \_\_\_\_\_ DATE \_\_\_\_\_  
 CONTACT DATACHEM LABS PRIOR TO SENDING SAMPLES

2. Date 11/18/05 Purchase Order No. \_\_\_\_\_ 4. Quote No. \_\_\_\_\_  
 3. Company Name Red Montana Tech DCL Project Manager \_\_\_\_\_  
 Address 1300 West Paul St  
Bozeman MT 59701  
 Person to Contact Terry Spear  
 Telephone (406) 496-4445  
 Fax Telephone (406) 496-4050  
 E-mail Address T.Spear@redmt.com  
 Billing Address (if different from above) \_\_\_\_\_

6. REQUEST FOR ANALYSES

Laboratory Use Only	Client Sample Number	Matrix*	Sample Volume	ANALYSES REQUESTED - Use method number if known	Units**
<u>DSE 113 FB</u>	<u>1156</u>	<u>Filter</u>	<u>662.4 L</u>	<u>gravimetric</u>	
<u>74</u>	<u>1157</u>	<u>F. Filter</u>	<u>399.4 L</u>	<u>gravimetric</u>	
<u>75</u>	<u>1166</u>	<u>Filter</u>	<u>635.1 L</u>	<u>gravimetric</u>	
<u>76</u>	<u>1167</u>	<u>Filter</u>	<u>303.4 L</u>	<u>gravimetric</u>	
<u>77</u>	<u>1176</u>	<u>Filter</u>	<u>712.3 L</u>	<u>gravimetric</u>	
<u>78</u>	<u>1177</u>	<u>Filter</u>	<u>682.5 L</u>	<u>gravimetric</u>	
	<u>116 G</u>	<u>Miscellaneous</u>		<u>IPM method TO 15 + TPH</u>	
	<u>116 SM</u>	<u>Miscellaneous</u>		<u>IPM method TO 15 + TPH</u>	
	<u>117 G</u>	<u>Miscellaneous</u>		<u>IPM method TO 15 + TPH</u>	
	<u>118 BQ</u>	<u>Quartz</u>	<u>700.0 L</u>	<u>FE/OC Method 50.00</u>	
<u>79</u>	<u>118 BG</u>	<u>Filter</u>	<u>400.0 L</u>	<u>gravimetric</u>	

\* Specify: Solid sorbent tube, e.g. Charcoal; Filter type; Impinger solution; Bulk sample; Blood; Urine; Tissue; Soil; Water; Other  
 \*\* 1 ug/sample 2 mg/m<sup>3</sup> 3 ppm 4 % 5 \_\_\_\_\_ (other) Please indicate one or more units in the column entitled Units\*\*

Comments \_\_\_\_\_

Possible Contamination and/or Chemical Hazards \_\_\_\_\_

7. Chain of Custody (Optional)

Relinquished by _____	Date/Time _____
Received by <u>R. A. Potts</u>	Date/Time <u>1/20</u>
Relinquished by <u>R. A. Potts</u>	Date/Time <u>1/20</u>
Received by _____	Date/Time _____
Relinquished by _____	Date/Time _____
Received by _____	Date/Time _____

960 West LeVoy Drive / Salt Lake City, UT 84123  
 DATACHEM LABORATORIES, INC.

800-356-9135 or 801-266-7700 / FAX: 801-268-9992  
 www.datachem.com



ANALYTICAL REPORT

Form ARF-AL
Page 1 of 2
Part 1 of 1
02160513183306RX

Date FEB 17 2005
Laboratory Group Name 05I-0480-01
Account No. 07003

Montana Tech
Attention: Terry Spear
1300 West Park Street
Butte, MT 59701

FAX (406) 496-4650
Telephone (406) 496-4445
E-mail tspear@mttech.edu

Sampling Collection and Shipment

Sampling Site Date of Collection
Date Samples Received at Laboratory February 11, 2005

Analysis

Method of Analysis NMAM 5040
Date(s) of Analysis February 15, 2005

Analytical Results

Table with 11 columns: Field Sample Number, Laboratory Number, Sample Type, Organic Carbon ug/sample, Elemental Carbon ug/sample, Total Carbon ug/sample, Organic Carbon ug/m3, Elemental Carbon ug/m3, Total Carbon ug/m3, Air Volume, and an empty column. Rows include samples 273, 272, B27Q and a Reporting Limit row.

! See comment on last page.
ND Parameter not detected above LOD.
NR Parameter not requested.
NA Parameter not applicable.
\*\* See comment on last page.
( ) Parameter between LOD and LOQ.

Analyst: Mei Qi Huang
Reviewer: Penny A. Foote

960 West LeVoy Drive / Salt Lake City, Utah 84123-2547
Phone (801) 266-7700
FAX (801) 268-9992
Web Page: www.datachem.com
E-mail: lab@datachem.com



ANALYTICAL REPORT

Form ARF-C  
Page 2 of 2  
02160513183306RX

FEB 17 2005

Date \_\_\_\_\_  
Laboratory Group Name 05I-0480-01

**General Set Comments**

Method Reference: NIOSH Manual of Analytical Methods (NMAM), fourth ed., 3/15/03

Sample analysis was performed on a representative 1x1.5 cm<sup>2</sup> area of the sample filter. The reported µg/sample values correspond to the entire exposed area of the sample. The µg/sample values assume an even distribution of organic and elemental carbon on the exposed area of the sample filter. The value for the exposed area is either specified by the client or calculated by subtracting 2 mm (the width of the cassette rim) from the edge of the filter.

The reported results have not been blank corrected.

mg/m<sup>3</sup> formula: Result / Volume

**General Lab Comments**

The results provided in this report relate only to the items tested. Samples were received in acceptable condition unless otherwise noted in the General Set Comments above. Samples have not been field blank corrected unless otherwise noted in the General Set Comments above. This test report shall not be reproduced, except in full, without written approval of DataChem Laboratories, Inc. This page is the concluding page of the report.

960 West LeVoy Drive / Salt Lake City, Utah 84123-2547  
Phone (801) 266-7700 Web Page: www.datachem.com  
FAX (801) 268-9992 E-mail: lab@datachem.com



**DATA  
CHEM**  
LABORATORIES, INC.

**ANALYTICAL REQUEST FORM**

1.  REGULAR Status *REG. STATUS*  
 RUSH Status Requested - ADDITIONAL CHARGE  
 RESULTS REQUIRED BY \_\_\_\_\_ DATE \_\_\_\_\_  
 CONTACT DATACHEM LABS PRIOR TO SENDING SAMPLES

2. Date 2/9/05 Purchase Order No. \_\_\_\_\_ 4. Quote No. \_\_\_\_\_  
 3. Company Name Montana Tech DCL Project Manager \_\_\_\_\_  
 Address 1300 West Park St  
Butte MT 59701 5. Sample Collection  
 Person to Contact Terry Spear Sampling Site \_\_\_\_\_  
 Telephone (406) 496-4445 Industrial Process \_\_\_\_\_  
 Fax Telephone (406) 496-4650 Date of Collection \_\_\_\_\_  
 E-mail Address TSpear@Mtech.edu Time Collected \_\_\_\_\_  
 Billing Address (if different from above) Date of Shipment \_\_\_\_\_  
 Chain of Custody No. \_\_\_\_\_

**6. REQUEST FOR ANALYSES**

Laboratory Use Only	Client Sample Number	Matrix	Sample Volume	ANALYSES REQUESTED - Use method number if known	Units**
<i>REG. 14973</i>	<i>273</i>	<i>Quartz Filter</i>	<i>457.29 L</i>	<i>EC/OC (NMAA 5000)</i>	
<i>LH</i>	<i>272</i>	<i>Quartz Filter</i>	<i>446.5 L</i>	<i>(NMAA 5000)</i>	
	<i>MG 274</i>	<i>ZF Filter</i>	<i>473.8 L</i>	<i>gravimetric (NMAA 5000)</i>	
	<i>MG 188</i>	<i>ZF Filter</i>	<i>486.9 L</i>	<i>gravimetric (NMAA 5000)</i>	
			<i>3490.5 cc</i>		
	<i>MV 27</i>	<i>Oil sample</i>	<i>3590.5 cc</i>	<i>NO2 (NMAA 6014)</i>	
	<i>MMX 27</i>		<i>3490.5 cc</i>	<i>NO (NMAA 6014)</i>	
	<i>M 27</i>	<i>Charcoal</i>	<i>35,953 cc</i>	<i>BET and Total HC (PMAA 101)</i>	
	<i>M 27</i>	<i>XAD</i>	<i>8225.6 cc</i>	<i>Methydisocyan (NMAA 2529)</i>	
	<i>MC 27</i>	<i>Miscan</i>		<i>VOC screen EPA 7015 (NMAA 2529)</i>	

\* Specify: Solid sorbent tube, e.g. Charcoal; Filter type; Impinger solution; Bulk sample; Blood; Urine; Tissue; Soil; Water; Other  
 \*\* 1 ug/sample 2 mg/m<sup>3</sup> 3 ppm 4 % 5 \_\_\_\_\_ (other) Please indicate one or more units in the column entitled Units\*\*

Comments \_\_\_\_\_

Possible Contamination and/or Chemical Hazards \_\_\_\_\_

**7. Chain of Custody (Optional)**

Relinquished by _____	Date/Time _____
Received by <u>R. [Signature]</u>	Date/Time <u>2/11</u>
Relinquished by _____	Date/Time _____
Received by _____	Date/Time _____
Relinquished by _____	Date/Time _____
Received by _____	Date/Time _____

960 West LeVoy Drive / Salt Lake City, UT 84123  
 DATACHEM LABORATORIES, INC.

800-356-9135 or 801-266-7700 / FAX: 801-268-9992  
 www.datachem.com



**DATA  
CHEM**  
LABORATORIES, INC.

### ANALYTICAL REQUEST FORM

1.  REGULAR Status 05/19/05  
 RUSH Status Requested - ADDITIONAL CHARGE  
 RESULTS REQUIRED BY \_\_\_\_\_ DATE \_\_\_\_\_  
 CONTACT DATACHEM LABS PRIOR TO SENDING SAMPLES

2. Date 2/9/05 Purchase Order No. \_\_\_\_\_ 4. Quote No. \_\_\_\_\_  
 3. Company Name Montana Tech DCL Project Manager \_\_\_\_\_  
 Address 1300 West Park St  
Butte MT 59701 5. Sample Collection  
 Person to Contact Terry Spear Sampling Site \_\_\_\_\_  
 Telephone (406) 496-4445 Industrial Process \_\_\_\_\_  
 Fax Telephone 406 496-4650 Date of Collection \_\_\_\_\_  
 E-mail Address T.Spear@mttech.edu Time Collected \_\_\_\_\_  
 Billing Address (if different from above) Date of Shipment \_\_\_\_\_  
 Chain of Custody No \_\_\_\_\_

**6. REQUEST FOR ANALYSES**

Laboratory Use Only	Client Sample Number	Matrix*	Sample Volume	ANALYSES REQUESTED - Use method number if known	Units**
<u>05F04995</u>	<u>B 27 Q</u>	<u>Quartzite</u>	<u>500 L</u>	<u>IC/OC (PARAM 8090)</u>	
	<u>B 27 C</u>	<u>ZFF/In</u>	<u>450 L</u>	<u>quartzite (NMAM 1501)</u>	
	<u>B 27</u>	<u>Charcoal</u>	<u>30,000 cc</u>	<u>BETX (NMAM 1501)</u>	
	<u>NO 227</u>	<u>Molsiew</u>	<u>3500 cc</u>	<u>NO2 (NMAM 6014)</u>	
	<u>YAD 27</u>	<u>XAD</u>	<u>6000 cc</u>	<u>Aldehyde/Carb (NMAM 2530)</u>	

\* Specify: Solid sorbent tube, e.g. Charcoal; Filter type; Impinger solution; Bulk sample; Blood; Urine; Tissue; Soil; Water; Other  
 \*\* 1 ug/sample 2 mg/m<sup>3</sup> 3 ppm 4 % 5 \_\_\_\_\_ (other) Please indicate one or more units in the column entitled Units\*\*

Comments \_\_\_\_\_

Possible Contamination and/or Chemical Hazards \_\_\_\_\_

**7. Chain of Custody (Optional)**

Relinquished by _____	Date/Time _____
Received by <u>R. Spitt</u>	Date/Time <u>2/9</u>
Relinquished by _____	Date/Time _____
Received by _____	Date/Time _____
Relinquished by _____	Date/Time _____
Received by _____	Date/Time _____

960 West LeVoy Drive / Salt Lake City, UT 84123  
 DATACHEM LABORATORIES, INC.

800-356-9135 or 801-266-7700 / FAX: 801-268-9992  
 www.datachem.com



ANALYTICAL REPORT

Form ARF-AL
Page 1 of 3
Part 1 of 2
02210519093802RX

Date FEB 22 2005
Laboratory Group Name 05I-0480-04
Account No. 07003

Montana Tech
Attention: Terry Spear
1300 West Park Street
Butte, MT 59701

FAX (406) 496-4650
Telephone (406) 496-4445
E-mail tspear@mttech.edu

Sampling Collection and Shipment

Sampling Site \_\_\_\_\_ Date of Collection \_\_\_\_\_
Date Samples Received at Laboratory February 11, 2005

Analysis

Method of Analysis NMAM 1501
Date(s) of Analysis February 18, 2005

Analytical Results

Table with 11 columns: Field Sample Number, Laboratory Number, Sample Type, Benzene mg/sample, Toluene mg/sample, Ethyl Benzene mg/sample, Xylene mg/sample, Total Petroleum Hydrocarbons mg/sample, Benzene ppm, Toluene ppm, Ethyl Benzene ppm. Rows include H27, B27, and Reporting Limit.

† See comment on last page.
ND Parameter not detected above LOD.
NR Parameter not requested.
NA Parameter not applicable.
\*\* See comment on last page.
( ) Parameter between LOD and LOQ.

Analyst: Young Hee Yoon
Reviewer: Vicki Hae-Lin Tsai

960 West LeVoy Drive / Salt Lake City, Utah 84123-2547
Phone (801) 266-7700
FAX (801) 268-9992
Web Page: www.datachem.com
E-mail: lab@datachem.com







ANALYTICAL REPORT

Form ARF-C  
Page 3 of 3  
02210519093802RX

Date FEB 22 2005  
Laboratory Group Name 05I-0480-04

General Set Comments

ppm formula:  $(24.45 * (\text{Result} * 1000)) / (\text{Volume} * \text{MW})$   
"Total Petroleum Hydrocarbons" is the sum of all peaks in the chromatogram  
minus the solvent and requested analyte peaks and quantitated against n-hexane.

General Lab Comments

The results provided in this report relate only to the items tested.  
Samples were received in acceptable condition unless otherwise noted in the General  
Set Comments above.  
Samples have not been field blank corrected unless otherwise noted in the General  
Set Comments above.  
This test report shall not be reproduced, except in full, without written approval  
of DataChem Laboratories, Inc.  
This page is the concluding page of the report.

960 West LeVoy Drive / Salt Lake City, Utah 84123-2547  
Phone (801) 266-7700 Web Page: [www.datachem.com](http://www.datachem.com)  
FAX (801) 268-9992 E-mail: [lab@datachem.com](mailto:lab@datachem.com)



**DATA  
CHEM**  
LABORATORIES, INC.

### ANALYTICAL REQUEST FORM

1.  REGULAR Status PSE-048504  
 RUSH Status Requested - ADDITIONAL CHARGE  
 RESULTS REQUIRED BY \_\_\_\_\_ DATE \_\_\_\_\_  
 CONTACT DATACHEM LABS PRIOR TO SENDING SAMPLES

2. Date 2/9/05 Purchase Order No. \_\_\_\_\_ 4. Quote No. \_\_\_\_\_  
 3. Company Name Montana Tech DCL Project Manager \_\_\_\_\_  
 Address 1300 West Park St  
Butte MT 59701 5. Sample Collection  
 Person to Contact Terry Spear Sampling Site \_\_\_\_\_  
 Telephone (406) 496-4445 Industrial Process \_\_\_\_\_  
 Fax Telephone (406) 491-4650 Date of Collection \_\_\_\_\_  
 E-mail Address TSpear@Mtech.edu Time Collected \_\_\_\_\_  
 Billing Address (if different from above) Date of Shipment \_\_\_\_\_  
 Chain of Custody No \_\_\_\_\_

**6. REQUEST FOR ANALYSES**

Laboratory Use Only	Client Sample Number	Matrix*	Sample Volume	ANALYSES REQUESTED - Use method number if known	Units**
	273	Quartz Filt.	457.24 L	EC/OC (NMAA 5000)	
	272	Quartz Filt.	466.5 L	(NMAA 5000)	
	MG 2P4	2" Filt.	473.8 L	gravimetric (NMAA 5000)	
	MG 1PB	2" Filt.	486.9 L	gravimetric (NMAA 5000)	
	MV 27	Dilution	3490.5 cc	NO <sub>2</sub> (NMAA 6014)	
	MX 27		3490.5 cc	NO (NMAA 6014)	
	M 27	Charcoal	35,953 cc	BET and total HC (NMAA 2519)	
	M 27	XAD	8228.6 cc	Aldehyde screen (NMAA 2519)	
	MC 27	Minican		VOC screen EPA 7015 (K615)	

\* Specify: Solid sorbent tube, e.g. Charcoal; Filter type; Impinger solution; Bulk sample; Blood; Urine; Tissue; Soil; Water; Other  
 \*\* 1. ug/sample 2. mg/m<sup>3</sup> 3. ppm 4. % 5. \_\_\_\_\_ (other) Please indicate one or more units in the column entitled Units\*\*

Comments \_\_\_\_\_

Possible Contamination and/or Chemical Hazards \_\_\_\_\_

**7. Chain of Custody (Optional)**

Relinquished by _____	Date/Time _____
Received by <u>R. [Signature]</u>	Date/Time <u>2/11</u>
Relinquished by _____	Date/Time _____
Received by _____	Date/Time _____
Relinquished by _____	Date/Time _____
Received by _____	Date/Time _____

960 West LeVoy Drive / Salt Lake City, UT 84123  
 DATACHEM LABORATORIES, INC.

800-356-9135 or 801-266-7700 / FAX: 801-268-9992  
 www.datachem.com



**DATA  
CHEM**  
LABORATORIES, INC.

### ANALYTICAL REQUEST FORM

1.  REGULAR Status (SEE ORDER)  
 RUSH Status Requested - ADDITIONAL CHARGE  
 RESULTS REQUIRED BY \_\_\_\_\_ DATE \_\_\_\_\_  
 CONTACT DATACHEM LABS PRIOR TO SENDING SAMPLES

2. Date 2/9/05 Purchase Order No. \_\_\_\_\_ 4. Quote No. \_\_\_\_\_  
 3. Company Name Montana Tech DCL Project Manager \_\_\_\_\_  
 Address 1300 West Park St  
Butte MT 59701 5. Sample Collection \_\_\_\_\_  
 Person to Contact Terry Spear Sampling Site \_\_\_\_\_  
 Telephone (406) 496-4445 Industrial Process \_\_\_\_\_  
 Fax Telephone (406) 496-4650 Date of Collection \_\_\_\_\_  
 E-mail Address TSpear@mttech.edu Time Collected \_\_\_\_\_  
 Billing Address (if different from above) Chain of Custody No. \_\_\_\_\_

**6. REQUEST FOR ANALYSES**

Laboratory Use Only	Client Sample Number	Matrix*	Sample Volume	ANALYSES REQUESTED - Use method number if known	Units**
	B 27 Q	Quartzite	500 L	IC / OC (MMAR 8090)	
	B 27 G	ZFF/In	450 L	Quartzite (MMAR 1501)	
1510498	B 27	Charcoal	30,000 cc	BETX (MMAR 1501)	
	N0227	Molsieve	3500 cc	NO2 (MMAR 1614)	
	BHAD27	XAD	6000 cc	Aldehydes (MMAR 2570)	

\* Specify: Solid sorbent tube, e.g. Charcoal; Filter type; Impinger solution; Bulk sample; Blood; Urine; Tissue; Soil; Water; Other  
 \*\* 1. ug/sample 2. mg/m<sup>3</sup> 3. ppm 4. % 5. \_\_\_\_\_ (other) Please indicate one or more units in the column entitled Units\*\*

Comments \_\_\_\_\_

Possible Contamination and/or Chemical Hazards \_\_\_\_\_

**7. Chain of Custody (Optional)**

Relinquished by _____	Date/Time _____
Received by <u>R. Spitt</u>	Date/Time <u>2/9</u>
Relinquished by _____	Date/Time _____
Received by _____	Date/Time _____
Relinquished by _____	Date/Time _____
Received by _____	Date/Time _____

960 West LeVoy Drive / Salt Lake City, UT 84123  
 DATACHEM LABORATORIES, INC.

800-356-9135 or 801-266-7700 / FAX: 801-268-9992  
 www.datachem.com







ANALYTICAL REPORT

Form ARF-AL  
 Page 3 of 4  
 Part 3 of 3  
 02200523492859RX

Date FEB 21 2005  
 Laboratory Group Name 05I-0480-06  
 Account No. 07003

Montana Tech  
 Attention: Terry Spear  
 1300 West Park Street  
 Butte, MT 59701

FAX (406) 496-4650  
 Telephone (406) 496-4445  
 E-mail tspear@mttech.edu

Sampling Collection and Shipment

Sampling Site \_\_\_\_\_ Date of Collection \_\_\_\_\_  
 Date Samples Received at Laboratory February 11, 2005

Analysis

Method of Analysis NMAM 2539  
 Date(s) of Analysis February 15, 2005

Analytical Results

Field Sample Number	Laboratory Number	Sample Type	Propionaldehyde BC/FID	Valeraldehyde BC/FID	Air Volume liters					
MX27	05I04985	TUBE	<0.015	<0.010	8.2256					
BXAD27	05I04986	TUBE	<0.021	<0.014	6.0					
Reporting Limit										

! See comment on last page.      \*\* See comment on last page.  
 ND Parameter not detected above LOD.      ( ) Parameter between LOD and LOQ.  
 NR Parameter not requested.  
 NA Parameter not applicable.

960 West LeVoy Drive / Salt Lake City, Utah 84123-2547  
 Phone (801) 266-7700      Web Page: www.datachem.com  
 FAX (801) 268-9992      E-mail: lab@datachem.com



ANALYTICAL REPORT

Form ARF-C  
Page 4 of 4  
02200523492859RX

Date FEB 21 2005  
Laboratory Group Name 05I-0480-06

**General Set Comments**

ppm formula:  $(24.45 * \text{Result}) / (\text{Volume} * \text{MW})$

**General Lab Comments**

The results provided in this report relate only to the items tested.  
Samples were received in acceptable condition unless otherwise noted in the General Set Comments above.  
Samples have not been field blank corrected unless otherwise noted in the General Set Comments above.  
This test report shall not be reproduced, except in full, without written approval of DataChem Laboratories, Inc.  
This page is the concluding page of the report.

960 West LeVoy Drive / Salt Lake City, Utah 84123-2547  
Phone (801) 266-7700 Web Page: [www.datachem.com](http://www.datachem.com)  
FAX (801) 268-9992 E-mail: [lab@datachem.com](mailto:lab@datachem.com)





**DATA  
CHEM**  
LABORATORIES, INC.

## ANALYTICAL REQUEST FORM

1.  REGULAR Status  
 RUSH Status Requested - ADDITIONAL CHARGE  
 RESULTS REQUIRED BY \_\_\_\_\_ DATE \_\_\_\_\_  
 CONTACT DATACHEM LABS PRIOR TO SENDING SAMPLES

2. Date 2/9/05 Purchase Order No. \_\_\_\_\_ 4. Quote No. \_\_\_\_\_  
 3. Company Name Montana Tech DCL Project Manager \_\_\_\_\_  
 Address 1300 West Park St  
Butte MT 59701 5. Sample Collection  
 Person to Contact Terry Spear Sampling Site \_\_\_\_\_  
 Telephone (406) 496-4445 Industrial Process \_\_\_\_\_  
 Fax Telephone (406) 496-4650 Date of Collection \_\_\_\_\_  
 E-mail Address TSpear@mttech.edu Time Collected \_\_\_\_\_  
 Billing Address (if different from above) Date of Shipment \_\_\_\_\_  
 Chain of Custody No. \_\_\_\_\_

### 6. REQUEST FOR ANALYSES

Laboratory Use Only	Client Sample Number	Matrix*	Sample Volume	ANALYSES REQUESTED - Use method number if known	Units**
	273	Quartz Filtr	457.24 L	EC/OC (NMAA 5060)	
	272	Quartz Filtr	466.5 L	(NMAA 5060)	
	MG 2P4	ZF Filter	473.8 L	gravimetric (NMAA 5060)	
	MG 1PB	ZF Filter	486.9 L	gravimetric (NMAA 5060)	
			3490.5 cc		
	MX 27	Polysorb	<del>3590.5</del> cc	NO <sub>2</sub> (NMAA 6014)	
	MX 27		3490.5 cc	NO (NMAA 6014)	
	M 27	charcoal	35,953 cc	BET & total HC (NMAA 1001)	
USE 04985	MX 27	XAD	8225.6 cc	Aldehyde screen (NMAA 2539)	
	MC 27	Minican		VOC screen EPA 7015 (NMAA 2539)	

\* Specify: Solid sorbent tube, e.g. Charcoal; Filter type; Impinger solution; Bulk sample; Blood; Urine; Tissue; Soil; Water; Other  
 \*\* 1. ug/sample 2. mg/m<sup>3</sup> 3 ppm 4 % 5 \_\_\_\_\_ (other) Please indicate one or more units in the column entitled Units\*\*

Comments \_\_\_\_\_

Possible Contamination and/or Chemical Hazards \_\_\_\_\_

### 7. Chain of Custody (Optional)

Relinquished by _____	Date/Time _____
Received by <u>R. [Signature]</u>	Date/Time <u>2/11</u>
Relinquished by _____	Date/Time _____
Received by _____	Date/Time _____
Relinquished by _____	Date/Time _____
Received by _____	Date/Time _____

960 West LeVoy Drive / Salt Lake City, UT 84123  
 DATACHEM LABORATORIES, INC.

800-356-9135 or 801-266-7700 / FAX: 801-268-9992  
 www.datachem.com



**DATA  
CHEM**  
LABORATORIES, INC.

## ANALYTICAL REQUEST FORM

1.  REGULAR Status  
 RUSH Status Requested - ADDITIONAL CHARGE  
 RESULTS REQUIRED BY \_\_\_\_\_ DATE \_\_\_\_\_  
 CONTACT DATACHEM LABS PRIOR TO SENDING SAMPLES

2. Date 2/9/05 Purchase Order No. \_\_\_\_\_ 4. Quote No. \_\_\_\_\_  
 3. Company Name Montana Tech DCL Project Manager \_\_\_\_\_  
 Address 1300 West Park St  
Butte MT 59701 5. Sample Collection  
 Person to Contact Terry Spear Sampling Site \_\_\_\_\_  
 Telephone (406) 496-4445 Industrial Process \_\_\_\_\_  
 Fax Telephone (406) 496-4650 Date of Collection \_\_\_\_\_  
 E-mail Address T.Spear@mttech.edu Time Collected \_\_\_\_\_  
 Billing Address (if different from above) Date of Shipment \_\_\_\_\_  
 Chain of Custody No. \_\_\_\_\_

### 6. REQUEST FOR ANALYSES

Laboratory Use Only	Client Sample Number	Matrix*	Sample Volume	ANALYSES REQUESTED - Use method number if known	Units**
	B 27 Q	WATER	500 L	IC/OC (NMAH 8090)	
	B 27 G	ZFF/In	450 L	quintilox (NMAH 1501)	
	B 27	Charcoal	30,000 cc	RETX (NMAH 1501)	
	N0227	Mol Sieve	3500 cc	NO <sub>2</sub> (NMAH 6514)	
NMAH 1501	BXAD 27	XAD	6000 cc	Aldehyde screen (NMAH 2530)	

\* Specify: Solid sorbent tube, e.g. Charcoal; Filter type; Impinger solution; Bulk sample; Blood; Urine; Tissue; Soil; Water; Other  
 \*\* 1 ug/sample 2 mg/m<sup>3</sup> 3 ppm 4 % 5 \_\_\_\_\_ (other) Please indicate one or more units in the column entitled Units\*\*

Comments \_\_\_\_\_

Possible Contamination and/or Chemical Hazards \_\_\_\_\_

### 7. Chain of Custody (Optional)

Relinquished by _____	Date/Time _____
Received by <u>R. Updegraff</u>	Date/Time <u>2/9</u>
Relinquished by _____	Date/Time _____
Received by _____	Date/Time _____
Relinquished by _____	Date/Time _____
Received by _____	Date/Time _____

960 West LeVoy Drive / Salt Lake City, UT 84123  
 DATACHEM LABORATORIES, INC.

800-356-9135 or 801-266-7700 / FAX: 801-266-9992  
 www.datachem.com



ANALYTICAL REPORT

Form ARF-AL  
 Page 1 of 2  
 Part 1 of 1  
 03030514021016RX

Date MAR 04 2005  
 Laboratory Group Name 05I-0676-02  
 Account No. 07003

Montana Tech  
 Attention: Terry Spear  
 1300 West Park Street  
 Butte, MT 59701

FAX (406) 496-4650  
 Telephone (406) 496-4445  
 E-mail tspear@mttech.edu

Sampling Collection and Shipment

Sampling Site \_\_\_\_\_ Date of Collection \_\_\_\_\_

Date Samples Received at Laboratory February 25, 2005

Analysis

Method of Analysis NMAM 5040

Date(s) of Analysis March 01, 2005

Analytical Results

Field Sample Number	Laboratory Number	Sample Type	Organic Carbon µg/sample	Elemental Carbon µg/sample	Total Carbon µg/sample	Organic Carbon mg/m <sup>3</sup>	Elemental Carbon mg/m <sup>3</sup>	Total Carbon mg/m <sup>3</sup>	Air Volume L
2194	05I06964	FILTER	47.	ND	47.	0.056	<0.0016	0.056	830.1
2192	05I06965	FILTER	13.	ND	13.	0.016	<0.0016	0.016	833.3
2204	05I06966	FILTER	15.	ND	15.	0.017	<0.0015	0.017	895.5
2202	05I06967	FILTER	42.	ND	42.	0.049	<0.0015	0.049	866.04
2224	05I06968	FILTER	40.	1.4	41.	0.046	0.0016	0.048	863.96
2222	05I06969	FILTER	21.	ND	21.	0.047	<0.0028	0.047	455.4
2225	05I06970	FILTER	41.	ND	41.	0.047	<0.0015	0.047	859.66
2345	05I06971	FILTER	6.2	ND	6.2	0.0081	<0.0017	0.0081	760.0
Reporting Limit			5.2	1.3					

† See comment on last page.  
 ND Parameter not detected above LOD.  
 NR Parameter not requested.  
 NA Parameter not applicable.

\*\* See comment on last page.  
 ( ) Parameter between LOD and LOQ.

Analyst: Wei Qi Huang

Reviewer: Penny A. Foote

960 West LeVoy Drive / Salt Lake City, Utah 84123-2547  
 Phone (801) 266-7700 Web Page: www.datachem.com  
 FAX (801) 268-9992 E-mail: lab@datachem.com



ANALYTICAL REPORT

Form ARF-C  
Page 2 of 2  
03030514021016RX

MAR 0 4 2005

Date \_\_\_\_\_  
Laboratory Group Name 05I-0676-02

**General Set Comments**

Method Reference: NIOSH Manual of Analytical Methods (NMAM), fourth ed., 3/15/03  
Sample analysis was performed on a representative 1x1.5 cm<sup>2</sup> area of the sample filter. The reported µg/sample values correspond to the entire exposed area of the sample. The µg/sample values assume an even distribution of organic and elemental carbon on the exposed area of the sample filter. The value for the exposed area is either specified by the client or calculated by subtracting 2 mm (the width of the cassette rim) from the edge of the filter.  
The reported results have not been blank corrected.

mg/m<sup>3</sup> formula: Result / Volume

**General Lab Comments**

The results provided in this report relate only to the items tested.  
Samples were received in acceptable condition unless otherwise noted in the General Set Comments above.  
Samples have not been field blank corrected unless otherwise noted in the General Set Comments above.  
This test report shall not be reproduced, except in full, without written approval of DataChem Laboratories, Inc.  
This page is the concluding page of the report.

960 West LeVoy Drive / Salt Lake City, Utah 84123-2547  
Phone (801) 266-7700 Web Page: www.datachem.com  
FAX (801) 268-9992 E-mail: lab@datachem.com

246



**DATA  
CHEM**  
LABORATORIES, INC.

**ANALYTICAL REQUEST FORM**

1.  REGULAR Status *JST-06700*  
 RUSH Status Requested - ADDITIONAL CHARGE  
 RESULTS REQUIRED BY \_\_\_\_\_  
 DATE \_\_\_\_\_  
 CONTACT DATACHEM LABS PRIOR TO SENDING SAMPLES

2. Date *2-22-05* Purchase Order No. \_\_\_\_\_ 4. Quote No. \_\_\_\_\_  
 3. Company Name *Mountain Tech* DCL Project Manager \_\_\_\_\_  
 Address *1360 West Park St* 5. Sample Collection \_\_\_\_\_  
*Butte MT 59701* Sampling Site \_\_\_\_\_  
 Person to Contact *Terry Spear* Industrial Process \_\_\_\_\_  
 Telephone (406) *496 4445* Date of Collection \_\_\_\_\_  
 Fax Telephone (406) *496 4680* Time Collected \_\_\_\_\_  
 E-mail Address *T Spear @ mttech.edy* Date of Shipment \_\_\_\_\_  
 Billing Address (if different from above) Chain of Custody No. \_\_\_\_\_

**6. REQUEST FOR ANALYSES**

Laboratory Use Only	Client Sample Number	Matrix*	Sample Volume	ANALYSES REQUESTED - Use method number if known	Units**
	220 N2	molecular sieve	14.0 L	NO <sub>2</sub> NM HM 6014	
	220 NX	molecular sieve	14.0 L	NO NM HM 6014	
	219 N2	molecular sieve	13.6 L	NO <sub>2</sub> NM HM 6014	
	219 NX	molecular sieve	13.6 L	NO NM HM 6014	
	219 NB	molecular sieve	14.0 L	NO <sub>2</sub> NM HM 6014	
	219 NXB	molecular sieve	14.0 L	NO NM HM 6014	
<i>JST-06700</i>	2194	Quartz Filter	830.1 L	EC/OC NM HM 6040	
<i>WS</i>	2192	" "	833.3 L	" " " " "	
<i>WLF</i>	2204	" "	895.5 L	" " " " "	
<i>WLF</i>	2202	" "	866.04 L	" " " " "	

\* Specify: Solid sorbent tube, e.g. Charcoal; Filter type; Impinger solution; Bulk sample; Blood; Urine; Tissue; Soil; Water; Other  
 \*\* 1 ug/sample 2 mg/m<sup>3</sup> 3 ppm 4.% 5. \_\_\_\_\_ (other) Please indicate one or more units in the column entitled Units\*\*

Comments \_\_\_\_\_

Possible Contamination and/or Chemical Hazards \_\_\_\_\_

**7. Chain of Custody (Optional)**

Relinquished by _____	Date/Time _____
Received by <i>R. P. Pitt</i>	Date/Time <i>2/25</i>
Relinquished by <i>R. P. Pitt</i>	Date/Time <i>2/25</i>
Received by <i>Mark H J</i>	Date/Time <i>2/28/05</i>
Relinquished by _____	Date/Time _____
Received by _____	Date/Time _____



# DATA CHEM

LABORATORIES, INC.

## ANALYTICAL REQUEST FORM

1.  REGULAR Status 057-007602  
 RUSH Status Requested - ADDITIONAL CHARGE  
 RESULTS REQUIRED BY \_\_\_\_\_ DATE \_\_\_\_\_  
 CONTACT DATACHEM LABS PRIOR TO SENDING SAMPLES

2. Date 2-22-05 Purchase Order No. \_\_\_\_\_ 4. Quote No. \_\_\_\_\_  
 3. Company Name Montana Tech DCL Project Manager \_\_\_\_\_  
 Address 1300 West Park St.  
Butte MT 59701 5. Sample Collection  
 Person to Contact Terry Spear Sampling Site \_\_\_\_\_  
 Telephone (406) 496 4445 Industrial Process \_\_\_\_\_  
 Fax Telephone (406) 496 4650 Date of Collection \_\_\_\_\_  
 E-mail Address tspear@mttech.edu Time Collected \_\_\_\_\_  
 Billing Address (if different from above) Date of Shipment \_\_\_\_\_  
 Chain of Custody No. \_\_\_\_\_

### 6. REQUEST FOR ANALYSES

Laboratory Use Only	Client Sample Number	Matrix*	Sample Volume	ANALYSES REQUESTED - Use method number if known	Units**
	2224	Quartz filter	863.96 L	HL/COC NMMAM 5040	
	2222	" "	466.4 L (455.4 L)	Verification w/ Client	
	2226	" "	859.66 L	" "	
	2345	" "	760.0 L	" "	
	2227	ZP filter	856.98 L	gravimetric	
	2207	" "	845.04 L	"	
	2201	" "	885.1 L	"	
	2191	" "	832.6 L	"	
	2197	" "	757.9 L	"	
	8432	" "	820.0 L	"	

\* Specify: Solid sorbent tube, e.g. Charcoal; Filter type; Impinger solution; Bulk sample; Blood; Urine; Tissue; Soil; Water; Other  
 \*\* 1 ug/sample 2. mg/m<sup>3</sup> 3 ppm 4. % 5 \_\_\_\_ (other) Please indicate one or more units in the column entitled Units\*\*

Comments \_\_\_\_\_

Possible Contamination and/or Chemical Hazards \_\_\_\_\_

### 7. Chain of Custody (Optional)

Relinquished by _____	Date/Time _____
Received by <u>Russ Potts</u>	Date/Time <u>2/25</u>
Relinquished by <u>Russ Potts</u>	Date/Time <u>2/25</u>
Received by <u>Mark H. J.</u>	Date/Time <u>02/28/05</u>
Relinquished by _____	Date/Time _____
Received by _____	Date/Time _____

960 West LeVoy Drive / Salt Lake City, UT 84123  
 DATACHEM LABORATORIES, INC.

800-356-9135 or 801-266-7700 / FAX: 801-268-9992  
 www.datachem.com



ANALYTICAL REPORT

Form ARF-AL  
Page 1 of 3  
Part 1 of 2  
03070514484688RX

Date MAR 07 2005

Laboratory Group Name 051-0676-03  
Account No. 07003

Montana Tech  
Attention: Terry Spear  
1300 West Park Street  
Butte, MT 59701

FAX (406) 496-4650  
Telephone (406) 496-4445  
E-mail tspear@mttech.edu

Sampling Collection and Shipment

Sampling Site \_\_\_\_\_ Date of Collection \_\_\_\_\_  
Date Samples Received at Laboratory February 25, 2005

Analysis

Method of Analysis NMAM 1501  
Date(s) of Analysis March 03, 2005 - March 04, 2005

Analytical Results

Field Sample Number	Laboratory Number	Sample Type	Benzene mg/sample	Ethyl Benzene mg/sample	Toluene mg/sample	Xylene mg/sample	Total Petroleum Hydrocarbons mg/sample	Benzene ppm	Ethyl Benzene ppm	Toluene ppm
2226	05106972	TUBE	ND	ND	ND	ND	0.049	<0.0060	<0.044	<0.051
222B	05106973	TUBE	ND	ND	ND	ND	0.014	<0.0061	<0.045	<0.052
222B2	05106974	TUBE	ND	ND	ND	ND	0.27	<0.015	<0.11	<0.12
B2B	05106975	TUBE	ND	ND	ND	ND	ND	<0.0063	<0.046	<0.053
219B	05106976	TUBE	ND	ND	ND	ND	0.045	<0.0052	<0.038	<0.044
220B	05106977	TUBE	ND	ND	ND	ND	0.043	<0.0057	<0.042	<0.048
Reporting Limit			0.001	0.01	0.01	0.01	0.01			

† See comment on last page.  
ND Parameter not detected above LOD.  
NR Parameter not requested.  
NA Parameter not applicable.

\*\* See comment on last page.  
( ) Parameter between LOD and LOQ.

Analyst: Robert B. Copenhafer  
Reviewer: Young-Hae Yoon *SS* Steven J. Sagas

960 West LeVoy Drive / Salt Lake City, Utah 84123-2547  
Phone (801) 266-7700 Web Page: [www.datachem.com](http://www.datachem.com)  
FAX (801) 268-9992 E-mail: [lab@datachem.com](mailto:lab@datachem.com)



ANALYTICAL REPORT

Form ARF-AL  
 Page 2 of 3  
 Part 2 of 2  
 03070514484688RX

MAR 07 2005

Date \_\_\_\_\_  
 Laboratory Group Name OSI-0676-03  
 Account No. 07003

Montana Tech  
 Attention: Terry Spear  
 1300 West Park Street  
 Butte, MT 59701

FAX (406) 496-4650  
 Telephone (406) 496-4445  
 E-mail tspear@mttech.edu

Sampling Collection and Shipment

Sampling Site \_\_\_\_\_ Date of Collection \_\_\_\_\_  
 Date Samples Received at Laboratory February 25, 2005

Analysis

Method of Analysis NMAM 1501  
 Date(s) of Analysis March 03, 2005 - March 04, 2005

Analytical Results

Field Sample Number	Laboratory Number	Sample Type	Xylene ppm	Total Petroleum Hydrocarbons ppm	Air Volume L					
2226	05I06972	TUBE	<0.044	0.26	52.5					
222B	05I06973	TUBE	<0.045	0.078	51.0					
222B2	05I06974	TUBE	<0.11	3.6	21.4					
B2B	05I06975	TUBE	<0.046	<0.057	50.0					
219B	05I06976	TUBE	<0.038	0.21	60.2					
220B	05I06977	TUBE	<0.042	0.22	55.1					
Reporting Limit										

† See comment on last page.      \*\* See comment on last page.  
 ND Parameter not detected above LOD.      ( ) Parameter between LOD and LOQ.  
 NR Parameter not requested.  
 NA Parameter not applicable.

960 West LeVoy Drive / Salt Lake City, Utah 84123-2547  
 Phone (801) 266-7700      Web Page: www.datachem.com  
 FAX (801) 268-9992      E-mail: lab@datachem.com





ANALYTICAL REPORT

Form ARF-C  
Page 3 of 3  
03070514484688RX

MAR 07 2005

Date \_\_\_\_\_

Laboratory Group Name 051-0676-03

**General Set Comments**

ppm formula:  $(24.45 * (\text{Result} * 1000)) / (\text{Volume} * \text{MW})$

Total petroleum hydrocarbons results were calculated by summing all chromatographic peak areas, excluding the solvent and analyte peaks, and quantitating the results against a hexane calibration curve.

**General Lab Comments**

The results provided in this report relate only to the items tested.  
Samples were received in acceptable condition unless otherwise noted in the General Set Comments above.  
Samples have not been field blank corrected unless otherwise noted in the General Set Comments above.  
This test report shall not be reproduced, except in full, without written approval of DataChem Laboratories, Inc.  
This page is the concluding page of the report.

960 West LeVoy Drive / Salt Lake City, Utah 84123-2547  
Phone (801) 266-7700 Web Page: [www.datachem.com](http://www.datachem.com)  
FAX (801) 268-9992 E-mail: [lab@datachem.com](mailto:lab@datachem.com)



**DATA  
CHEM**  
LABORATORIES, INC.

### ANALYTICAL REQUEST FORM

1.  REGULAR Status *OST 0090-03*  
 RUSH Status Requested - ADDITIONAL CHARGE  
 RESULTS REQUIRED BY \_\_\_\_\_  
 DATE \_\_\_\_\_  
 CONTACT DATACHEM LABS PRIOR TO SENDING SAMPLES

2. Date 2-22-05 Purchase Order No. \_\_\_\_\_ 4. Quote No. \_\_\_\_\_  
 3. Company Name Montana Tech DCL Project Manager \_\_\_\_\_  
 Address 1300 West Park St.  
Butte MT 59701 5. Sample Collection  
 Person to Contact Tevy Spear Sampling Site \_\_\_\_\_  
 Telephone (706) 496-4445 Industrial Process \_\_\_\_\_  
 Fax Telephone (706) 496-4650 Date of Collection \_\_\_\_\_  
 E-mail Address T.Spear@mttech.edu Time Collected \_\_\_\_\_  
 Billing Address (if different from above) Chain of Custody No. \_\_\_\_\_

6. REQUEST FOR ANALYSES

Laboratory Use Only	Client Sample Number	Matrix*	Sample Volume	ANALYSES REQUESTED - Use method number if known	Units**
	222 N 2	Molecular sieve	14.2 L	NO <sub>2</sub> N MAM 6014	
	222 N X	Molecular sieve	14.2 L	NO N MAM 6014	
OST-0090-03	222 C	charcoal	52.5 L	BETX and total hydrocarbons N MAM 1501	
73	222 B	charcoal	51.0 L	BETX and total hydrocarbons N MAM 1501	
74	222 B 2	charcoal	21.4 L	BETX and total hydrocarbons N MAM 1501	
75	B 2 B	charcoal	50.0 L	BETX and total hydrocarbons N MAM 1501	
76	219 B	charcoal	60.2 L	BETX and total hydrocarbons N MAM 1501	
77	220 B	charcoal	55.1 L	BETX and total hydrocarbons N MAM 1501	
	220 X	XAD	16.1 L	Aldehyde screen N MAM 2539	
	219 X	XAD	15.3 L	Aldehyde screen N MAM 2539	
	2X B	XAD	15.0 L	Aldehyde screen N MAM 2539	

\* Specify: Solid sorbent tube, e.g. Charcoal; Filter type; Impinger solution; Bulk sample; Blood; Urine; Tissue; Soil; Water; Other  
 \*\* 1. ug/sample 2. mg/m<sup>3</sup> 3. ppm 4. % 5. \_\_\_\_\_ (other) Please indicate one or more units in the column entitled Units\*\*

Comments \_\_\_\_\_  
 Possible Contamination and/or Chemical Hazards \_\_\_\_\_

7. Chain of Custody (Optional)

Relinquished by _____	Date/Time _____
Received by <u>Ronald Potts</u>	Date/Time <u>2/25</u>
Relinquished by <u>Ronald Potts</u>	Date/Time <u>2/25</u>
Received by _____	Date/Time _____
Relinquished by _____	Date/Time _____
Received by _____	Date/Time _____

960 West LeVoy Drive / Salt Lake City, UT 84123  
 DATACHEM LABORATORIES, INC.

800-356-9135 or 801-266-7700 / FAX: 801-268-9992  
 www.datachem.com



ANALYTICAL REPORT

Form ARF-AL  
 Page 1 of 4  
 Part 1 of 3  
 03030503270634RX

Date MAR 04 2005  
 Laboratory Group Name 05I-0676-04  
 Account No. 07003

Montana Tech  
 Attention: Terry Spear  
 1300 West Park Street  
 Butte, MT 59701

FAX (406) 496-4650  
 Telephone (406) 496-4445  
 E-mail tspear@mttech.edu

Sampling Collection and Shipment

Sampling Site \_\_\_\_\_ Date of Collection \_\_\_\_\_  
 Date Samples Received at Laboratory February 25, 2005

Analysis

Method of Analysis NMAM 2539  
 Date(s) of Analysis March 02, 2005

Analytical Results

Field Sample Number	Laboratory Number	Sample Type	Acetaldehyde µg/sample GC/FID	Acrolein µg/sample GC/FID	Butyraldehyde µg/sample GC/FID	Formaldehyde µg/sample GC/FID	Heptanal µg/sample GC/FID	Hexanal µg/sample GC/FID	Iso-Valeraldehyde µg/sample GC/FID	Propionaldehyde µg/sample GC/FID
220X	05I06978	TUBE	ND	ND	ND	ND	ND	ND	ND	ND
219X	05I06979	TUBE	ND	ND	ND	ND	ND	ND	ND	ND
2XB	05I06980	TUBE	ND	ND	ND	ND	ND	ND	ND	ND
Reporting Limit			0.3	0.3	0.3	0.3	0.3	0.3	0.3	0.3

! See comment on last page.  
 ND Parameter not detected above LOD.  
 NR Parameter not requested.  
 NA Parameter not applicable.  
 \*\* See comment on last page.  
 ( ) Parameter between LOD and LOQ.

F. Rejali  
 Analyst: Fred M. Rejali  
David Hue Li Jan  
 Reviewer:

960 West LeVoy Drive / Salt Lake City, Utah 84123-2547  
 Phone (801) 266-7700 Web Page: www.datachem.com  
 FAX (801) 268-9992 E-mail: lab@datachem.com



ANALYTICAL REPORT

Form ARF-AL  
 Page 2 of 4  
 Part 2 of 3  
 03030503270634RX

Date MAR 04 2005  
 Laboratory Group Name 05I-0676-04  
 Account No. 07003

Montana Tech  
 Attention: Terry Spear  
 1300 West Park Street  
 Butte, MT 59701

FAX (406) 496-4650  
 Telephone (406) 496-4445  
 E-mail tspear@mttech.edu

Sampling Collection and Shipment

Sampling Site \_\_\_\_\_ Date of Collection \_\_\_\_\_  
 Date Samples Received at Laboratory February 25, 2005

Analysis

Method of Analysis NMAM 2539  
 Date(s) of Analysis March 02, 2005

Analytical Results

Field Sample Number	Laboratory Number	Sample Type	Valeraldehyde µg/sample GC/FID	Acetaldehyde µg GC/FID	Acrolein µg GC/FID	Butyraldehyde µg GC/FID	Formaldehyde µg GC/FID	Heptanal µg GC/FID	Hexanal µg GC/FID	Iso-Valeraldehyde µg GC/FID
220X	05I06978	TUBE	ND	<0.010	<0.0081	<0.0063	<0.015	<0.0040	<0.0045	<0.0053
219X	05I06979	TUBE	ND	<0.011	<0.0086	<0.0066	<0.016	<0.0042	<0.0048	<0.0056
2XB	05I06980	TUBE	ND	<0.011	<0.0087	<0.0068	<0.016	<0.0043	<0.0049	<0.0057
Reporting Limit			0.3							

† See comment on last page.  
 ND Parameter not detected above LOD.  
 NR Parameter not requested.  
 NA Parameter not applicable.  
 \*\* See comment on last page.  
 ( ) Parameter between LOD and LOQ.

960 West LeVoy Drive / Salt Lake City, Utah 84123-2547  
 Phone (801) 266-7700 Web Page: www.datachem.com  
 FAX (801) 268-9992 E-mail: lab@datachem.com



ANALYTICAL REPORT

Form ARF-AL  
 Page 3 of 4  
 Part 3 of 3  
 03030503270634RX

Date MAR 04 2005  
 Laboratory Group Name 05I-0676-04  
 Account No. 07003

Montana Tech  
 Attention: Terry Spear  
 1300 West Park Street  
 Butte, MT 59701

FAX (406) 496-4650  
 Telephone (406) 496-4445  
 E-mail tspear@mttech.edu

Sampling Collection and Shipment

Sampling Site \_\_\_\_\_ Date of Collection \_\_\_\_\_  
 Date Samples Received at Laboratory February 25, 2005

Analysis

Method of Analysis NMAM 2539  
 Date(s) of Analysis March 02, 2005

Analytical Results

Field Sample Number	Laboratory Number	Sample Type	Propionaldehyde GC/FID	Valeraldehyde GC/FID	Air Volume Liters GC/FID						
220X	05I06978	TUBE	<0.0078	<0.0053	16.1						
219X	05I06979	TUBE	<0.0083	<0.0056	15.3						
2XB	05I06980	TUBE	<0.0084	<0.0057	15.0						
Reporting Limit											

† See comment on last page.      \*\* See comment on last page.  
 ND Parameter not detected above LOD.      ( ) Parameter between LOD and LOQ.  
 NR Parameter not requested.  
 NA Parameter not applicable.

960 West LeVoy Drive / Salt Lake City, Utah 84123-2547  
 Phone (801) 266-7700      Web Page: www.datachem.com  
 FAX (801) 268-9992      E-mail: lab@datachem.com



ANALYTICAL REPORT

Form ARF-C  
Page 4 of 4  
03030503270634RX

MAR 04 2005

Date \_\_\_\_\_

Laboratory Group Name 051-0676-04 \_\_\_\_\_

**General Set Comments**

ppm formula:  $(24.45 * \text{Result}) / (\text{Volume} * \text{MW})$

**General Lab Comments**

The results provided in this report relate only to the items tested.  
Samples were received in acceptable condition unless otherwise noted in the General Set Comments above.  
Samples have not been field blank corrected unless otherwise noted in the General Set Comments above.  
This test report shall not be reproduced, except in full, without written approval of DataChem Laboratories, Inc.  
This page is the concluding page of the report.

960 West LeVoy Drive / Salt Lake City, Utah 84123-2547  
Phone (801) 266-7700 Web Page: [www.datachem.com](http://www.datachem.com)  
FAX (801) 268-9992 E-mail: [lab@datachem.com](mailto:lab@datachem.com)



**DATA  
CHEM**  
LABORATORIES, INC.

## ANALYTICAL REQUEST FORM

1.  REGULAR Status *OST - 2/22/05*

RUSH Status Requested - ADDITIONAL CHARGE

RESULTS REQUIRED BY \_\_\_\_\_

DATE

CONTACT DATACHEM LABS PRIOR TO SENDING SAMPLES

2. Date 2-22-05 Purchase Order No. \_\_\_\_\_ 4. Quote No. \_\_\_\_\_  
 3. Company Name Montana Tech DCL Project Manager \_\_\_\_\_  
 Address 1300 West Park St. 5. Sample Collection \_\_\_\_\_  
Butte MT 59701 Sampling Site \_\_\_\_\_  
 Person to Contact Terry Spear Industrial Process \_\_\_\_\_  
 Telephone (406) 496-4465 Date of Collection \_\_\_\_\_  
 Fax Telephone (406) 496-4650 Time Collected \_\_\_\_\_  
 E-mail Address T.Spear@mttech.edu Date of Shipment \_\_\_\_\_  
 Billing Address (if different from above) Chain of Custody No. \_\_\_\_\_

### 6. REQUEST FOR ANALYSES

Laboratory Use Only	Client Sample Number	Matrix*	Sample Volume	ANALYSES REQUESTED - Use method number if known	Units**
	222N2	Molecular sieve	14.2 L	NO <sub>2</sub> NMAM 6014	
	222NX	Molecular sieve	14.2 L	NO NMAM 6014	
	222C	Charcoal	52.5 L	BETX and Total hydrocarbons NMAM 1501	
	222B	Charcoal	51.0 L	BETX and Total hydrocarbons NMAM 1501	
	222B2	Charcoal	21.4 L	BETX and Total hydrocarbons NMAM 1501	
	B2B	Charcoal	60.0 L	BETX and Total hydrocarbons NMAM 1501	
	219B	Charcoal	60.2 L	BETX and Total hydrocarbons NMAM 1501	
	220B	Charcoal	55.1 L	BETX and Total hydrocarbons NMAM 1501	
OSTEX097X	220X	XAD	16.1 L	Aldehyde screen NMAM 2539	
	219X	XAD	15.3 L	Aldehyde screen NMAM 2539	
	2XB	XAD	16.0 L	Aldehyde screen NMAM 2539	

\* Specify: Solid sorbent tube, e.g. Charcoal; Filter type; Impinger solution; Bulk sample; Blood; Urine; Tissue; Soil; Water; Other  
 \*\* 1. ug/sample 2. mg/m<sup>3</sup> 3. ppm 4. % 5. \_\_\_\_\_ (other) Please indicate one or more units in the column entitled Units\*\*

Comments \_\_\_\_\_

Possible Contamination and/or Chemical Hazards \_\_\_\_\_

### 7. Chain of Custody (Optional)

Relinquished by _____	Date/Time _____
Received by <u>Ronald Pottner</u>	Date/Time <u>2/25</u>
Relinquished by <u>Ronald Pottner</u>	Date/Time <u>2/25</u>
Received by _____	Date/Time _____
Relinquished by _____	Date/Time _____
Received by _____	Date/Time _____

960 West LeVoy Drive / Salt Lake City, UT 84123  
 DATACHEM LABORATORIES, INC.

800-356-9135 or 801-266-7700 / FAX: 801-268-9992  
 www.datachem.com



ANALYTICAL REPORT

Form ARF-AL  
 Page 1 of 2  
 Part 1 of 1  
 03040509575371RX

Date MAR 04 2005  
 Laboratory Group Name 05I-0676-05  
 Account No. 07003

Montana Tech  
 Attention: Terry Spear  
 1300 West Park Street  
 Butte, MT 59701

FAX (406) 496-4650  
 Telephone (406) 496-4445  
 E-mail tspear@mttech.edu

Sampling Collection and Shipment

Sampling Site \_\_\_\_\_ Date of Collection \_\_\_\_\_  
 Date Samples Received at Laboratory February 25, 2005

Analysis

Method of Analysis NMAM 0500  
 Date(s) of Analysis March 04, 2005

Analytical Results

Field Sample Number	Laboratory Number	Sample Type	Total Weight µg/sample	Total Weight µg/m <sup>3</sup>	Air Volume liters						
2227	05I06981	FILTER	ND	<0.02	855.98						
2207	05I06982	FILTER	ND	<0.02	845.04						
2201	05I06983	FILTER	ND	<0.02	885.1						
2191	05I06984	FILTER	ND	<0.02	832.6						
2197	05I06985	FILTER	ND	<0.03	757.9						
5432	05I06986	FILTER	ND	<0.02	820.0						
Reporting Limit			0.02								

See comment on last page.  
 ND Parameter not detected above LOD.  
 NR Parameter not requested.  
 NA Parameter not applicable.

\*\* See comment on last page.  
 ( ) Parameter between LOD and LOQ.

P.P. Steen  
 Analyst: Peter P. Steen  
Johnathan M. Yonk  
 Reviewer: Johnathan M. Yonk

960 West LeVoy Drive / Salt Lake City, Utah 84123-2547  
 Phone (801) 266-7700 Web Page: www.datachem.com  
 FAX (801) 268-9992 E-mail: lab@datachem.com





ANALYTICAL REPORT

Form ARF-C  
Page 2 of 2  
03040509575371RX

MAR 04 2005

Date \_\_\_\_\_  
Laboratory Group Name 051-0676-05

**General Set Comments**

Results are not blank corrected.

**General Lab Comments**

The results provided in this report relate only to the items tested.  
Samples were received in acceptable condition unless otherwise noted in the General Set Comments above.  
Samples have not been field blank corrected unless otherwise noted in the General Set Comments above.  
This test report shall not be reproduced, except in full, without written approval of DataChem Laboratories, Inc.  
This page is the concluding page of the report.

960 West LeVoy Drive / Salt Lake City, Utah 84123-2547  
Phone (801) 266-7700 Web Page: [www.datachem.com](http://www.datachem.com)  
FAX (801) 268-9992 E-mail: [lab@datachem.com](mailto:lab@datachem.com)



**DATA  
CHEM**  
LABORATORIES, INC.

### ANALYTICAL REQUEST FORM

1.  REGULAR Status *OST-2010-05*  
 RUSH Status Requested - ADDITIONAL CHARGE  
 RESULTS REQUIRED BY \_\_\_\_\_ DATE \_\_\_\_\_  
 CONTACT DATACHEM LABS PRIOR TO SENDING SAMPLES

2. Date *2-22-05* Purchase Order No. \_\_\_\_\_ 4. Quote No. \_\_\_\_\_  
 3. Company Name *Montana Tech* DCL Project Manager \_\_\_\_\_  
 Address *1300 West Park St.* 5. Sample Collection \_\_\_\_\_  
*Butte MT 59701* Sampling Site \_\_\_\_\_  
 Person to Contact *Terry Spear* Industrial Process \_\_\_\_\_  
 Telephone (406) *496 4445* Date of Collection \_\_\_\_\_  
 Fax Telephone (406) *496 4650* Time Collected \_\_\_\_\_  
 E-mail Address *tspear@mttech.edu* Date of Shipment \_\_\_\_\_  
 Billing Address (if different from above) Chain of Custody No \_\_\_\_\_

6. REQUEST FOR ANALYSES

Laboratory Use Only	Client Sample Number	Matrix*	Sample Volume	ANALYSES REQUESTED - Use method number if known	Units**
	2224	Quartz filter	863.96 L	HL/OC N/A/A/5040	
	2222	" "	456.4 L	" " " "	
	2226	" "	859.56 L	" " " "	
	2345	" "	760.0 L	" " " "	
	2227	2P filter	856.98 L	gravimetric	
	2207	" "	845.04 L	"	
	2201	" "	885.1 L	"	
	2191	" "	832.6 L	"	
	2197	" "	757.9 L	"	
	5432	" "	820.0 L	"	

\* Specify: Solid sorbent tube, e.g. Charcoal; Filter type; Impinger solution; Bulk sample; Blood; Urine; Tissue; Soil; Water; Other  
 \*\* 1 ug/sample 2 mg/m<sup>3</sup> 3 ppm 4 % 5 \_\_\_\_\_ (other) Please indicate one or more units in the column entitled Units\*\*

Comments \_\_\_\_\_

Possible Contamination and/or Chemical Hazards \_\_\_\_\_

7. Chain of Custody (Optional)

Relinquished by _____	Date/Time _____
Received by <i>Ronald Pott</i>	Date/Time <i>2/25</i>
Relinquished by <i>Ronald Pott</i>	Date/Time <i>2/25</i>
Received by _____	Date/Time _____
Relinquished by _____	Date/Time _____
Received by _____	Date/Time _____

960 West LeVoy Drive / Salt Lake City, UT 84123  
 DATACHEM LABORATORIES, INC.

800-356-9135 or 801-266-7700 / FAX: 801-268-9992  
 www.datachem.com

## **Appendix E**



COVER PAGE

ANALYTICAL REPORT FOR JAN 27 2005  
Montana Tech

Phone (406) 496-4445 Fax (406) 496-4650  
E-mail: tspear@mttech.edu

Form COVER-V1.4  
01260516083581  
Page 1



DCL Report Group : 05I-0167-07

Date Printed : 26-JAN-05 16:08

Project Protocol #: P021C001  
Client Ref Number : Not Provided  
Release Number : Not Provided

Analysis Method(s): TO-15

Montana Tech  
Attention: Terry Spear  
1300 West Park Street  
Butte, MT 59701

<u>Client Sample Name</u>	<u>Laboratory Sample Name</u>	<u>Date Sampled</u>	<u>Date Received</u>
116 G	05I01380	Not Provided	20-JAN-05
116 SM	05I01381	Not Provided	20-JAN-05
117 G	05I01382	Not Provided	20-JAN-05
# 1 MINI CAN	05I01383	Not Provided	20-JAN-05
Method Blank	BL-227387-1	NA	NA
LCS	QC-227387-1	NA	NA
LCS Dup	QD-227387-1	NA	NA

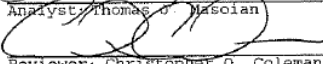
*Thomas J. Masoian* 1.26.05  
 Analyst: Thomas J. Masoian Date  
  
 Reviewer: Christopher Q. Coleman Date 1.27.05

960 West LeVoy Drive / Salt Lake City, Utah 84123-2547  
Phone (801) 266-7700 Web Page: www.datachem.com  
FAX (801) 268-9992 E-mail: lab@datachem.com



FORM H (TYPE I)  
SINGLE METHOD ANALYSES

Form RLIMS63H-V1.4  
01260516204292  
Page 2

SAMPLE GROUP COMMENTS



G050M01X

DCL Report Group : 05I-0167-07  
Date Printed : 26-JAN-05 16:20

Client Name : Montana Tech

Release Number : Not Provided

Sample Group Comments

Analyzed by GC/MS according to method T015

PQL - Practical Quantitation Limit - Lowest standard that is detectable  
MDL - Method Detection Limit - Statistically derived value using 40 CFR methods

The "E" qualifier indicates a reported value above the analytical linear range

General Information

The DCL QC Database maintains all numerical figures which are input from the pertinent data source. These data have not been rounded to significant figures nor have they been moisture corrected. Reports generated from the system, however, list data which have been rounded to the number of significant figures requested by the client or deemed appropriate for the method. This may create minor discrepancies between data which appear on the QC Summary Forms (Forms B-G) and those that would be calculated from rounded analytical results. Additionally, if a moisture correction is performed, differences will be observed between the QC data and the surrogate data reported on Form A (or other report forms) and corresponding data reported on QC Summary Forms. In these cases, the Form A will indicate the "Report Basis" as well as the moisture value used for making the correction.  
Report generation options: BX

Result Symbol Definitions

ND - Not Detected above the MDL (LLD or MDC for radiochemistry).  
\*\* - No result could be reported, see sample comments for details

Qualifier Symbol Definitions

U - Not Detected above the MDL (LLD or MDC for radiochemistry).  
B - For organic analyses the qualifier indicates that this analyte was found in the method blank.  
For inorganic analyses the qualifier signifies the value is between the MDL and PQL.  
J - For organic analyses the qualifier indicates that the value is between the MDL and the PQL.  
It is also used for indicating an estimated value for tentatively identified compounds in mass spectrometry where a 1:1 response is assumed.

QC Flag Symbol Definitions

\* - Parameter outside of specified QC limits

960 West LeVoy Drive / Salt Lake City, Utah 84123-2547  
Phone (801) 266-7700 Web Page: www.datachem.com  
FAX (801) 268-9992 E-mail: lab@datachem.com



FORM A (TYPE I)  
SINGLE METHOD ANALYSES

Form RLIMS63A-V1.4  
01260516204292  
Page 3

SAMPLE ANALYSIS DATA SHEET



Date Printed : 26-JAN-05 16:20  
Client Name : Montana Tech  
Client Ref Number : Not Provided  
Sampling Site : Not Provided  
Release Number : Not Provided  
Date Received : 20-JAN-05 00:00

Client Sample Name: 116 G  
DCL Sample Name : 05I01380  
DCL Report Group : 05I-0167-07  
Matrix : AIR  
Date Sampled : Not Provided  
Reporting Units : PPB V/V  
Report Basis :  As Received  Dried

DCL Preparation Group: Not Applicable  
Date Prepared : Not Applicable  
Preparation Method : Not Applicable  
Aliquot Weight/Volume: 200 mL  
Net Weight/Volume : Not Required

DCL Analysis Group: G050R00G  
Analysis Method : TO-15  
Instrument Type : GC/MS VO  
Instrument ID : 5972-O  
Column Type : DB-1  
 Primary  
 Confirmation

Analytical Results

Analyte	Date Analyzed	MDL	Result	Comment	Qual.	Dilution	PQL
Dichlorodifluoromethane	21-JAN-05 17:24	0.150	0.52			1	0.5
Chloromethane	21-JAN-05 17:24	0.187	ND			1	0.5
Freon 114	21-JAN-05 17:24	0.155	ND			1	0.5
Vinyl Chloride	21-JAN-05 17:24	0.180	ND			1	0.5
Bromomethane	21-JAN-05 17:24	0.176	ND			1	0.5
Chloroethane	21-JAN-05 17:24	0.249	ND			1	0.5
Freon 11	21-JAN-05 17:24	0.132	0.26		J	1	0.5
cis-1,2-Dichloroethene	21-JAN-05 17:24	0.0938	ND			1	0.5
Carbon Disulfide	21-JAN-05 17:24	0.130	0.35		J	1	0.5
Freon 113	21-JAN-05 17:24	0.124	ND			1	0.5
Acetone	21-JAN-05 17:24	0.179	6.2			1	0.5
Methylene Chloride	21-JAN-05 17:24	0.117	0.47		J	1	0.5
trans-1,2-Dichloroethene	21-JAN-05 17:24	0.100	ND			1	0.5
1,1-Dichloroethane	21-JAN-05 17:24	0.143	ND			1	0.5
Vinyl Acetate	21-JAN-05 17:24	0.0642	ND			1	0.5
1,1-Dichloroethene	21-JAN-05 17:24	0.105	ND			1	0.5
2-Butanone	21-JAN-05 17:24	0.237	3.5			1	0.5
Chloroform	21-JAN-05 17:24	0.127	ND			1	0.5
1,1,1-Trichloroethane	21-JAN-05 17:24	0.122	ND			1	0.5
Carbon Tetrachloride	21-JAN-05 17:24	0.161	ND			1	0.5
Benzene	21-JAN-05 17:24	0.0939	2.2			1	0.5
1,2-Dichloroethane	21-JAN-05 17:24	0.101	ND			1	0.5
Trichloroethene	21-JAN-05 17:24	0.109	ND			1	0.5
1,2-Dichloropropane	21-JAN-05 17:24	0.0669	ND			1	0.5
Bromodichloromethane	21-JAN-05 17:24	0.138	ND			1	0.5
cis-1,3-Dichloropropene	21-JAN-05 17:24	0.0979	ND			1	0.5
4-Methyl-2-Pentanone	21-JAN-05 17:24	0.0747	2.3			1	0.5
Toluene	21-JAN-05 17:24	0.120	69.		E	1	0.5
trans-1,3-Dichloropropene	21-JAN-05 17:24	0.0788	ND			1	0.5
1,1,2-Trichloroethane	21-JAN-05 17:24	0.174	ND			1	0.5
Tetrachloroethene	21-JAN-05 17:24	0.117	0.24		J	1	0.5
2-Hexanone	21-JAN-05 17:24	0.0887	ND			1	0.5
Dibromochloromethane	21-JAN-05 17:24	0.125	ND			1	0.5
1,2-Dibromethane	21-JAN-05 17:24	0.117	ND			1	0.5
Chlorobenzene	21-JAN-05 17:24	0.118	ND			1	0.5
Ethylbenzene	21-JAN-05 17:24	0.0872	45.		E	1	0.5
m,p-Xylene	21-JAN-05 17:24	0.215	220		E	1	1.0
o-Xylene	21-JAN-05 17:24	0.103	110		E	1	0.5
Styrene	21-JAN-05 17:24	0.0625	0.55			1	0.5
Bromoform	21-JAN-05 17:24	0.118	ND			1	0.5
1,1,2,2-Tetrachloroethane	21-JAN-05 17:24	0.140	ND			1	0.5

960 West LeVoy Drive / Salt Lake City, Utah 84123-2547  
Phone (801) 266-7700 Web Page: www.datachem.com  
FAX (801) 268-9992 E-mail: lab@datachem.com



FORM A (TYPE I)  
SINGLE METHOD ANALYSES

Form RLIMS63A-V1.4  
01260516204292  
Page 4

SAMPLE ANALYSIS DATA SHEET



Date Printed : 26-JAN-05 16:20  
Client Name : Montana Tech

DCL Sample Name : 05I01380  
DCL Report Group : 05I-0167-07

Analytical Results

Analyte	Date Analyzed	MDL	Result	Comment	Qual.	Dilution	FQL
Benzyl Chloride	21-JAN-05 17:24	0.0856	ND			1	0.5
4-Ethyl toluene	21-JAN-05 17:24	0.0888	34.		E	1	0.5
1,3,5-Trimethylbenzene	21-JAN-05 17:24	0.0592	51.		E	1	0.5
1,2,4-Trimethylbenzene	21-JAN-05 17:24	0.0756	220		E	1	0.5
1,3-Dichlorobenzene	21-JAN-05 17:24	0.133	ND			1	0.5
1,4-Dichlorobenzene	21-JAN-05 17:24	0.133	ND			1	0.5
1,2-Dichlorobenzene	21-JAN-05 17:24	0.107	ND			1	0.5
1,2,4-Trichlorobenzene	21-JAN-05 17:24	0.149	ND			1	0.5
Hexachlorobutadiene	21-JAN-05 17:24	0.232	ND			1	0.5
Methyl t-Butyl Ether	21-JAN-05 17:24	0.111	ND			1	0.5
Total Petroleum Hydrocarbon	21-JAN-05 17:24		630		J	1	

Tentatively Identified Compound Results

Analyte(Retention Time)	Date Analyzed	Result	Comment	Qual.	Dilution
Propene(4.47)	21-JAN-05 17:24	1.3		J	1
Ethanol(5.63)	21-JAN-05 17:24	49.		J	1
Isopropyl Alcohol(6.22)	21-JAN-05 17:24	98.		J	1
Hexane(8.50)	21-JAN-05 17:24	2.0		J	1
Ethyl Acetate(8.53)	21-JAN-05 17:24	4.2		J	1
Pentane, 2,3-dimethyl-(10.23)	21-JAN-05 17:24	7.3		J	1
Pentane, 2,2,4-trimethyl-(10.74)	21-JAN-05 17:24	17.		J	1
Heptane(10.94)	21-JAN-05 17:24	4.4		J	1
CYCLOHEXANE, METHYL-(11.57)	21-JAN-05 17:24	9.1		J	1
Hexane, 2,4-dimethyl-(11.79)	21-JAN-05 17:24	8.8		J	1
Pentane, 2,3,4-trimethyl-(12.21)	21-JAN-05 17:24	9.2		J	1
Heptane, 2-methyl-(12.51)	21-JAN-05 17:24	6.1		J	1
Hexane, 2,2,5-trimethyl-(12.95)	21-JAN-05 17:24	11.		J	1
Benzene, (1-methyl)ethyl-(15.76)	21-JAN-05 17:24	9.3		J	1
BENZENE, PROPYL-(16.34)	21-JAN-05 17:24	22.		J	1
Benzene, 1-ethyl-2-methyl-(16.83)	21-JAN-05 17:24	40.		J	1
Benzene, (2-methylpropyl)-(17.38)	21-JAN-05 17:24	6.3		J	1
Benzene, 1,2,3-trimethyl-(17.64)	21-JAN-05 17:24	48.		J	1
Indane(17.90)	21-JAN-05 17:24	16.		J	1
Benzene, 1-methyl-3-propyl-(18.09)	21-JAN-05 17:24	26.		J	1
Benzene, 1,2,3,4-tetramethyl-(18.19)	21-JAN-05 17:24	30.		J	1
Benzene, (1-methylpropyl)-(18.40)	21-JAN-05 17:24	8.7		J	1
Benzene, 4-ethyl-1,2-dimethyl-(18.55)	21-JAN-05 17:24	22.		J	1
Benzene, 2-ethyl-1,3-dimethyl-(18.69)	21-JAN-05 17:24	19.		J	1
Benzene, 1,2,4,5-tetramethyl-(19.26)	21-JAN-05 17:24	7.2		J	1
Benzene, 1-ethyl-3,5-dimethyl-(19.33)	21-JAN-05 17:24	8.9		J	1
Benzene, 2-ethenyl-1,4-dimethyl(19.87)	21-JAN-05 17:24	8.3		J	1
Naphthalene(20.44)	21-JAN-05 17:24	8.5		J	1

960 West LeVoy Drive / Salt Lake City, Utah 84123-2547  
Phone (801) 266-7700 Web Page: www.datachem.com  
FAX (801) 268-9992 E-mail: lab@datachem.com



FORM A (TYPE I)  
SINGLE METHOD ANALYSES

Form RLIMS63A-V1.4  
01260516204292  
Page 5

SAMPLE ANALYSIS DATA SHEET



Date Printed : 26-JAN-05 16:20  
Client Name : Montana Tech  
Client Ref Number : Not Provided  
Sampling Site : Not Provided  
Release Number : Not Provided  
Date Received : 20-JAN-05 00:00

Client Sample Name: 116 SM  
DCL Sample Name : 05I01381  
DCL Report Group : 05I-0167-07  
Matrix : AIR  
Date Sampled : Not Provided  
Reporting Units : PPB V/V  
Report Basis :  As Received  Dried

DCL Preparation Group: Not Applicable  
Date Prepared : Not Applicable  
Preparation Method : Not Applicable  
Aliquot Weight/Volume: 200 mL  
Net Weight/Volume : Not Required

DCL Analysis Group: G050R00G  
Analysis Method : TO-15  
Instrument Type : GC/MS VO  
Instrument ID : 5972-0  
Column Type : DB-1  
 Primary  
 Confirmation

Analytical Results

Analyte	Date Analyzed	MDL	Result	Comment	Qual.	Dilution	PQL
Dichlorodifluoromethane	21-JAN-05 18:05	0.150	3.2			1	0.5
Chloromethane	21-JAN-05 18:05	0.187	1.5			1	0.5
Freon 114	21-JAN-05 18:05	0.155	ND			1	0.5
Vinyl Chloride	21-JAN-05 18:05	0.180	ND			1	0.5
Bromomethane	21-JAN-05 18:05	0.176	ND			1	0.5
Chloroethane	21-JAN-05 18:05	0.249	ND			1	0.5
Freon 11	21-JAN-05 18:05	0.132	0.97			1	0.5
cis-1,2-Dichloroethene	21-JAN-05 18:05	0.0938	ND			1	0.5
Carbon Disulfide	21-JAN-05 18:05	0.130	ND			1	0.5
Freon 113	21-JAN-05 18:05	0.124	ND			1	0.5
Acetone	21-JAN-05 18:05	0.179	ND			1	0.5
Methylene Chloride	21-JAN-05 18:05	0.117	4.4			1	0.5
trans-1,2-Dichloroethene	21-JAN-05 18:05	0.100	ND			1	0.5
1,1-Dichloroethane	21-JAN-05 18:05	0.143	ND			1	0.5
Vinyl Acetate	21-JAN-05 18:05	0.0642	ND			1	0.5
1,1-Dichloroethene	21-JAN-05 18:05	0.105	ND			1	0.5
2-Butanone	21-JAN-05 18:05	0.237	17.			1	0.5
Chloroform	21-JAN-05 18:05	0.127	ND			1	0.5
1,1,1-Trichloroethane	21-JAN-05 18:05	0.122	ND			1	0.5
Carbon Tetrachloride	21-JAN-05 18:05	0.161	ND			1	0.5
Benzene	21-JAN-05 18:05	0.0939	2.4			1	0.5
1,2-Dichloroethane	21-JAN-05 18:05	0.101	ND			1	0.5
Trichloroethene	21-JAN-05 18:05	0.109	0.22		J	1	0.5
1,2-Dichloropropane	21-JAN-05 18:05	0.0669	ND			1	0.5
Bromodichloromethane	21-JAN-05 18:05	0.138	ND			1	0.5
cis-1,3-Dichloropropene	21-JAN-05 18:05	0.0979	ND			1	0.5
4-Methyl-2-Pentanone	21-JAN-05 18:05	0.0747	3.8			1	0.5
Toluene	21-JAN-05 18:05	0.120	6.2			1	0.5
trans-1,3-Dichloropropene	21-JAN-05 18:05	0.0788	ND			1	0.5
1,1,2-Trichloroethane	21-JAN-05 18:05	0.174	ND			1	0.5
Tetrachloroethene	21-JAN-05 18:05	0.117	0.73			1	0.5
2-Hexanone	21-JAN-05 18:05	0.0887	ND			1	0.5
Dibromochloromethane	21-JAN-05 18:05	0.125	ND			1	0.5
1,2-Dibromoethane	21-JAN-05 18:05	0.117	ND			1	0.5
Chlorobenzene	21-JAN-05 18:05	0.118	ND			1	0.5
Ethylbenzene	21-JAN-05 18:05	0.0872	1.1			1	0.5
m,p-Xylene	21-JAN-05 18:05	0.215	4.8			1	1.0
o-Xylene	21-JAN-05 18:05	0.103	1.7			1	0.5
Styrene	21-JAN-05 18:05	0.0625	1.4			1	0.5
Bromoform	21-JAN-05 18:05	0.118	ND			1	0.5
1,1,2,2-Tetrachloroethane	21-JAN-05 18:05	0.140	ND			1	0.5

960 West LeVoy Drive / Salt Lake City, Utah 84123-2547  
Phone (801) 266-7700 Web Page: www.datachem.com  
FAX (801) 268-9992 E-mail: lab@datachem.com





FORM A (TYPE I)  
SINGLE METHOD ANALYSES

Form RLIMS63A-V1.4  
01260516204292  
Page 6

SAMPLE ANALYSIS DATA SHEET



Date Printed : 26-JAN-05 16:20  
Client Name : Montana Tech

DCL Sample Name : 05I01381  
DCL Report Group : 05I-0167-07

Analytical Results

Analyte	Date Analyzed	MDL	Result	Comment	Qual.	Dilution	PQL
Benzyl Chloride	21-JAN-05 18:05	0.0856	ND			1	0.5
4-Ethyl toluene	21-JAN-05 18:05	0.0888	0.39		J	1	0.5
1,3,5-Trimethylbenzene	21-JAN-05 18:05	0.0592	0.41		J	1	0.5
1,2,4-Trimethylbenzene	21-JAN-05 18:05	0.0756	1.7			1	0.5
1,3-Dichlorobenzene	21-JAN-05 18:05	0.133	ND			1	0.5
1,4-Dichlorobenzene	21-JAN-05 18:05	0.133	ND			1	0.5
1,2-Dichlorobenzene	21-JAN-05 18:05	0.107	ND			1	0.5
1,2,4-Trichlorobenzene	21-JAN-05 18:05	0.149	ND			1	0.5
Hexachlorobutadiene	21-JAN-05 18:05	0.232	ND			1	0.5
Methyl t-Butyl Ether	21-JAN-05 18:05	0.111	ND			1	0.5
Total Petroleum Hydrocarbon	21-JAN-05 18:05		70.		J	1	

Tentatively Identified Compound Results

Analyte(Retention Time)	Date Analyzed	Result	Comment	Qual.	Dilution
Propene(4.45)	21-JAN-05 18:05	2.3		J	1
Isobutane(4.81)	21-JAN-05 18:05	7.7		J	1
1-Propene, 2-methyl-(4.97)	21-JAN-05 18:05	4.2		J	1
Butane(5.05)	21-JAN-05 18:05	15.		J	1
2-Butene(5.12)	21-JAN-05 18:05	5.0		J	1
Ethanol(5.85)	21-JAN-05 18:05	63.		J	1
C5 hydrocarbon(5.95)	21-JAN-05 18:05	44.		J	1
Pentane(6.36)	21-JAN-05 18:05	8.3		J	1
methane, dimethoxy-(6.59)	21-JAN-05 18:05	7.7		J	1
Silane, methoxytrimethyl-(7.61)	21-JAN-05 18:05	13.		J	1
Pentane, 2-methyl-(7.77)	21-JAN-05 18:05	14.		J	1
Silanol, trimethyl-(7.85)	21-JAN-05 18:05	8.2		J	1
Pentane, 3-methyl-(8.11)	21-JAN-05 18:05	2.8		J	1
Hexane(8.49)	21-JAN-05 18:05	4.9		J	1
Ethyl Acetate(8.53)	21-JAN-05 18:05	2.0		J	1
CYCLOPENTANE, METHYL-(9.20)	21-JAN-05 18:05	2.3		J	1
Heptane(10.93)	21-JAN-05 18:05	0.56		J	1
Limonene(17.83)	21-JAN-05 18:05	3.8		J	1

960 West LeVoy Drive / Salt Lake City, Utah 84123-2547  
Phone (801) 266-7700 Web Page: www.datachem.com  
FAX (801) 268-9992 E-mail: lab@datachem.com



FORM A (TYPE I)  
SINGLE METHOD ANALYSES

Form RLIMS63A-V1.4  
01260516204292  
Page 7

SAMPLE ANALYSIS DATA SHEET



Date Printed : 26-JAN-05 16:20  
Client Name : Montana Tech  
Client Ref Number : Not Provided  
Sampling Site : Not Provided  
Release Number : Not Provided  
Date Received : 20-JAN-05 00:00

Client Sample Name: 117 G  
DCL Sample Name : 05I01382  
DCL Report Group : 05I-0167-07  
Matrix : AIR  
Date Sampled : Not Provided  
Reporting Units : PPB V/V  
Report Basis :  As Received  Dried

DCL Preparation Group: Not Applicable  
Date Prepared : Not Applicable  
Preparation Method : Not Applicable  
Aliquot Weight/Volume: 200 mL  
Net Weight/Volume : Not Required

DCL Analysis Group: G050R00G  
Analysis Method : TO-15  
Instrument Type : GC/MS VO  
Instrument ID : 5972-0  
Column Type : DB-1  
 Primary  
 Confirmation

Analytical Results

Analyte	Date Analyzed	MDL	Result	Comment	Qual.	Dilution	PQL
Dichlorodifluoromethane	21-JAN-05 18:47	0.150	0.40		J	1	0.5
Chloromethane	21-JAN-05 18:47	0.187	1.2			1	0.5
Freon 114	21-JAN-05 18:47	0.155	ND			1	0.5
Vinyl Chloride	21-JAN-05 18:47	0.180	ND			1	0.5
Bromomethane	21-JAN-05 18:47	0.176	ND			1	0.5
Chloroethane	21-JAN-05 18:47	0.249	ND			1	0.5
Freon 11	21-JAN-05 18:47	0.132	0.22		J	1	0.5
cis-1,2-Dichloroethene	21-JAN-05 18:47	0.0938	ND			1	0.5
Carbon Disulfide	21-JAN-05 18:47	0.130	ND			1	0.5
Freon 113	21-JAN-05 18:47	0.124	ND			1	0.5
Acetone	21-JAN-05 18:47	0.179	33.		E	1	0.5
Methylene Chloride	21-JAN-05 18:47	0.117	0.38		J	1	0.5
trans-1,2-Dichloroethene	21-JAN-05 18:47	0.100	ND			1	0.5
1,1-Dichloroethane	21-JAN-05 18:47	0.143	ND			1	0.5
Vinyl Acetate	21-JAN-05 18:47	0.0642	ND			1	0.5
1,1-Dichloroethene	21-JAN-05 18:47	0.105	ND			1	0.5
2-Butanone	21-JAN-05 18:47	0.237	5.3			1	0.5
Chloroform	21-JAN-05 18:47	0.127	ND			1	0.5
1,1,1-Trichloroethane	21-JAN-05 18:47	0.122	ND			1	0.5
Carbon Tetrachloride	21-JAN-05 18:47	0.161	ND			1	0.5
Benzene	21-JAN-05 18:47	0.0939	0.38		J	1	0.5
1,2-Dichloroethane	21-JAN-05 18:47	0.101	ND			1	0.5
Trichloroethene	21-JAN-05 18:47	0.109	ND			1	0.5
1,2-Dichloropropane	21-JAN-05 18:47	0.0669	ND			1	0.5
Bromodichloromethane	21-JAN-05 18:47	0.138	ND			1	0.5
cis-1,3-Dichloropropene	21-JAN-05 18:47	0.0979	ND			1	0.5
4-Methyl-2-Pentanone	21-JAN-05 18:47	0.0747	4.4			1	0.5
Toluene	21-JAN-05 18:47	0.120	2.8			1	0.5
trans-1,3-Dichloropropene	21-JAN-05 18:47	0.0788	ND			1	0.5
1,1,2-Trichloroethane	21-JAN-05 18:47	0.174	ND			1	0.5
Tetrachloroethene	21-JAN-05 18:47	0.117	ND			1	0.5
2-Hexanone	21-JAN-05 18:47	0.0887	ND			1	0.5
Dibromochloromethane	21-JAN-05 18:47	0.125	ND			1	0.5
1,2-Dibromoethane	21-JAN-05 18:47	0.117	ND			1	0.5
Chlorobenzene	21-JAN-05 18:47	0.118	ND			1	0.5
Ethylbenzene	21-JAN-05 18:47	0.0872	0.35		J	1	0.5
m,p-Xylene	21-JAN-05 18:47	0.215	1.5			1	1.0
o-Xylene	21-JAN-05 18:47	0.103	0.63			1	0.5
Styrene	21-JAN-05 18:47	0.0625	0.43		J	1	0.5
Bromoform	21-JAN-05 18:47	0.118	ND			1	0.5
1,1,2,2-Tetrachloroethane	21-JAN-05 18:47	0.140	ND			1	0.5

960 West LeVoy Drive / Salt Lake City, Utah 84123-2547  
Phone (801) 266-7700 Web Page: www.datachem.com  
FAX (801) 268-9992 E-mail: lab@datachem.com



FORM A (TYPE I)  
SINGLE METHOD ANALYSES

Form RLIMS63A-V1.4  
01260516204292  
Page 8

SAMPLE ANALYSIS DATA SHEET



Date Printed : 26-JAN-05 16:20  
Client Name : Montana Tech

DCL Sample Name : 05I01382  
DCL Report Group : 05I-0167-07

Analytical Results

Analyte	Date Analyzed	MDL	Result	Comment	Qual.	Dilution	PQL
Benzyl Chloride	21-JAN-05 18:47	0.0856	ND			1	0.5
4-Ethyl toluene	21-JAN-05 18:47	0.0888	ND			1	0.5
1,3,5-Trimethylbenzene	21-JAN-05 18:47	0.0592	ND			1	0.5
1,2,4-Trimethylbenzene	21-JAN-05 18:47	0.0756	0.61			1	0.5
1,3-Dichlorobenzene	21-JAN-05 18:47	0.133	ND			1	0.5
1,4-Dichlorobenzene	21-JAN-05 18:47	0.133	ND			1	0.5
1,2-Dichlorobenzene	21-JAN-05 18:47	0.107	ND			1	0.5
1,2,4-Trichlorobenzene	21-JAN-05 18:47	0.149	ND			1	0.5
Hexachlorobutadiene	21-JAN-05 18:47	0.232	ND			1	0.5
Methyl t-Butyl Ether	21-JAN-05 18:47	0.111	ND			1	0.5
Total Petroleum Hydrocarbon	21-JAN-05 18:47		16.		J	1	

Tentatively Identified Compound Results

Analyte (Retention Time)	Date Analyzed	Result	Comment	Qual.	Dilution
Propene (4.47)	21-JAN-05 18:47	0.68		J	1
Isopropyl Alcohol (6.42)	21-JAN-05 18:47	31.		J	1
Silane, methoxytrimethyl- (7.61)	21-JAN-05 18:47	8.6		J	1
Silanol, trimethyl- (7.74)	21-JAN-05 18:47	9.4		J	1
Ethyl Acetate (8.54)	21-JAN-05 18:47	1.0		J	1

960 West LeVoy Drive / Salt Lake City, Utah 84123-2547  
Phone (801) 266-7700 Web Page: www.datachem.com  
FAX (801) 268-9992 E-mail: lab@datachem.com



FORM A (TYPE I)  
SINGLE METHOD ANALYSES

Form RLIMS63A-V1.4  
01260516204292  
Page 9

SAMPLE ANALYSIS DATA SHEET



Date Printed : 26-JAN-05 16:20  
Client Name : Montana Tech  
Client Ref Number : Not Provided  
Sampling Site : Not Provided  
Release Number : Not Provided  
Date Received : 20-JAN-05 00:00

Client Sample Name: # 1 MINI CAN  
DCL Sample Name : 05I01383  
DCL Report Group : 05I-0167-07  
Matrix : AIR  
Date Sampled : Not Provided  
Reporting Units : PPB V/V  
Report Basis :  As Received  Dried

DCL Preparation Group: Not Applicable  
Date Prepared : Not Applicable  
Preparation Method : Not Applicable  
Aliquot Weight/Volume: 200 mL  
Net Weight/Volume : Not Required

DCL Analysis Group: G050R00G  
Analysis Method : TO-15  
Instrument Type : GC/MS VO  
Instrument ID : 5972-0  
Column Type : DB-1  
 Primary  
 Confirmation

Analytical Results

Analyte	Date Analyzed	MDL	Result	Comment	Qual.	Dilution	PQL
Dichlorodifluoromethane	21-JAN-05 19:27	0.150	0.47		J	1	0.5
Chloromethane	21-JAN-05 19:27	0.187	2.8			1	0.5
Freon 114	21-JAN-05 19:27	0.155	ND			1	0.5
Vinyl Chloride	21-JAN-05 19:27	0.180	ND			1	0.5
Bromomethane	21-JAN-05 19:27	0.176	ND			1	0.5
Chloroethane	21-JAN-05 19:27	0.249	ND			1	0.5
Freon 11	21-JAN-05 19:27	0.132	ND			1	0.5
cis-1,2-Dichloroethene	21-JAN-05 19:27	0.0938	ND			1	0.5
Carbon Disulfide	21-JAN-05 19:27	0.130	ND			1	0.5
Freon 113	21-JAN-05 19:27	0.124	ND			1	0.5
Acetone	21-JAN-05 19:27	0.179	11.			1	0.5
Methylene Chloride	21-JAN-05 19:27	0.117	1.5			1	0.5
trans-1,2-Dichloroethene	21-JAN-05 19:27	0.100	ND			1	0.5
1,1-Dichloroethane	21-JAN-05 19:27	0.143	ND			1	0.5
Vinyl Acetate	21-JAN-05 19:27	0.0642	ND			1	0.5
1,1-Dichloroethene	21-JAN-05 19:27	0.105	ND			1	0.5
2-Butanone	21-JAN-05 19:27	0.237	17.			1	0.5
Chloroform	21-JAN-05 19:27	0.127	ND			1	0.5
1,1,1-Trichloroethane	21-JAN-05 19:27	0.122	ND			1	0.5
Carbon Tetrachloride	21-JAN-05 19:27	0.161	ND			1	0.5
Benzene	21-JAN-05 19:27	0.0939	0.86			1	0.5
1,2-Dichloroethane	21-JAN-05 19:27	0.101	ND			1	0.5
Trichloroethene	21-JAN-05 19:27	0.109	ND			1	0.5
1,2-Dichloropropane	21-JAN-05 19:27	0.0669	ND			1	0.5
Bromodichloromethane	21-JAN-05 19:27	0.138	ND			1	0.5
cis-1,3-Dichloropropene	21-JAN-05 19:27	0.0979	ND			1	0.5
4-Methyl-2-Pentanone	21-JAN-05 19:27	0.0747	1.4			1	0.5
Toluene	21-JAN-05 19:27	0.120	6.5			1	0.5
trans-1,3-Dichloropropene	21-JAN-05 19:27	0.0788	ND			1	0.5
1,1,2-Trichloroethane	21-JAN-05 19:27	0.174	ND			1	0.5
Tetrachloroethene	21-JAN-05 19:27	0.117	1.1			1	0.5
2-Hexanone	21-JAN-05 19:27	0.0887	ND			1	0.5
Dibromochloromethane	21-JAN-05 19:27	0.125	ND			1	0.5
1,2-Dibromoethane	21-JAN-05 19:27	0.117	ND			1	0.5
Chlorobenzene	21-JAN-05 19:27	0.118	ND			1	0.5
Ethylbenzene	21-JAN-05 19:27	0.0872	1.0			1	0.5
m,p-Xylene	21-JAN-05 19:27	0.215	4.1			1	1.0
o-Xylene	21-JAN-05 19:27	0.103	1.5			1	0.5
Styrene	21-JAN-05 19:27	0.0625	5.7			1	0.5
Bromoform	21-JAN-05 19:27	0.118	ND			1	0.5
1,1,2,2-Tetrachloroethane	21-JAN-05 19:27	0.140	ND			1	0.5

960 West LeVoy Drive / Salt Lake City, Utah 84123-2547  
Phone (801) 266-7700 Web Page: www.datachem.com  
FAX (801) 268-9992 E-mail: lab@datachem.com



FORM A (TYPE I)  
SINGLE METHOD ANALYSES

Form RLIMS63A-V1.4  
01270512103945  
Page 10

SAMPLE ANALYSIS DATA SHEET



Date Printed : 27-JAN-05 12:06  
Client Name : Montana Tech

DCL Sample Name : 05I01383  
DCL Report Group : 05I-0167-07

Analytical Results

Analyte	Date Analyzed	MDL	Result	Comment	Qual.	Dilution	PQL
Benzyl Chloride	21-JAN-05 19:27	0.0856	ND			1	0.5
4-Ethyl toluene	21-JAN-05 19:27	0.0888	0.25		J	1	0.5
1,3,5-Trimethylbenzene	21-JAN-05 19:27	0.0592	0.27		J	1	0.5
1,2,4-Trimethylbenzene	21-JAN-05 19:27	0.0756	0.89			1	0.5
1,3-Dichlorobenzene	21-JAN-05 19:27	0.133	ND			1	0.5
1,4-Dichlorobenzene	21-JAN-05 19:27	0.133	ND			1	0.5
1,2-Dichlorobenzene	21-JAN-05 19:27	0.107	ND			1	0.5
1,2,4-Trichlorobenzene	21-JAN-05 19:27	0.149	ND			1	0.5
Hexachlorbutadiene	21-JAN-05 19:27	0.232	ND			1	0.5
Methyl t-Butyl Ether	21-JAN-05 19:27	0.111	ND			1	0.5
Total Petroleum Hydrocarbon	21-JAN-05 19:27		34.		J	1	

Tentatively Identified Compound Results

Analyte(Retention Time)	Date Analyzed	Result	Comment	Qual.	Dilution
Isopropyl Alcohol(6.48)	21-JAN-05 19:27	130		J	1
Silane, methoxytrimethyl-(7.61)	21-JAN-05 19:27	85.		J	1
Silanol, trimethyl-(7.87)	21-JAN-05 19:27	11.		J	1
Ethyl Acetate(8.52)	21-JAN-05 19:27	2.9		J	1
Silane, triethoxypropyl-(12.61)	21-JAN-05 19:27	3.5		J	1

960 West LeVoy Drive / Salt Lake City, Utah 84123-2547  
Phone (801) 266-7700 Web Page: www.datachem.com  
FAX (801) 268-9992 E-mail: lab@datachem.com



FORM J (TYPE I)  
SINGLE METHOD ANALYSES  
QUALITY CONTROL DATA SHEET  
LABORATORY CONTROL SAMPLE (LCS)  
LABORATORY CONTROL DUPL (LCD)

Form RLIMS63J-V1.4  
01260516204292  
Page 11



Client Name : Montana Tech  
Release Number : Not Provided  
Matrix : AIR  
Reporting Units : ppb v/v

DCL Sample Name : QC-227387-1  
Date Printed : 26-JAN-05 16:20

DCL Analysis Group: G050R00G  
Analysis Method : TO15  
Instrument Type : GC/MS VO  
Instrument ID : 5972-0  
Column Type : DB-1  
 Primary  
 Confirmation

DCL Preparation Group: Not Applicable  
Date Prepared : Not Applicable  
Preparation Method : Not Applicable

QC Limit Type : Method

Analytical Results

Analyte	Date Analyzed	Target	Result	Percent Recovery	QC Limits	QC Flag
Methylene Chloride	21-JAN-05 14:01	10.0	10.3	103.	65.0/135.	
1,1-Dichloroethene	21-JAN-05 14:01	10.0	10.1	101.	65.0/135.	
Trichloroethene	21-JAN-05 14:01	10.0	10.6	106.	65.0/135.	
Toluene	21-JAN-05 14:01	10.0	10.1	101.	65.0/135.	
1,1,2,2-Tetrachloroethane	21-JAN-05 14:01	10.0	9.43	94.3	65.0/135.	



DCL Sample Name : QD-227387-1

Analytical Results

Analyte	Date Analyzed	Duplicate Result	Percent Recovery	Mean	Range	RPD	QC Limits	QC Flag
Methylene Chloride	21-JAN-05 14:42	9.69	96.9	9.98	0.581	5.8	0.00/25.0	
1,1-Dichloroethene	21-JAN-05 14:42	8.92	89.2	9.49	1.15	12.	0.00/25.0	
Trichloroethene	21-JAN-05 14:42	10.2	102.	10.4	0.397	3.8	0.00/25.0	
Toluene	21-JAN-05 14:42	10.2	102.	10.2	0.0450	0.44	0.00/25.0	
1,1,2,2-Tetrachloroethane	21-JAN-05 14:42	9.74	97.4	9.59	0.306	3.2	0.00/25.0	

960 West LeVoy Drive / Salt Lake City, Utah 84123-2547  
Phone (801) 266-7700 Web Page: www.datachem.com  
FAX (801) 268-9992 E-mail: lab@datachem.com



FORM C (TYPE I)  
SINGLE METHOD ANALYSES

Form RLIMS63C-VL.4

01260516204292

Page 12

QUALITY CONTROL DATA SHEET  
BLANK SAMPLE



S050R001

Client Name : Montana Tech  
Release Number : Not Provided

DCL Sample Name : BL-227387-1  
Date Printed : 26-JAN-05 16:20

Matrix : AIR  
Reporting Units : PPB V/V

DCL Analysis Group: G050R00G  
Analysis Method : TO-15  
Instrument Type : GC/MS VO  
Instrument ID : 5972-o  
Column Type : DB-1

DCL Preparation Group: Not Applicable  
Date Prepared : Not Applicable  
Preparation Method : Not Applicable

Primary  
 Confirmation

QC Limit Type : Method

Analytical Results

Analyte	Date Analyzed	Result	MDL	CRDL
Dichlorodifluoromethane	21-JAN-05 16:04	ND	0.562	1.0
Chloromethane	21-JAN-05 16:04	ND	0.370	1.0
Freon 114	21-JAN-05 16:04	ND	0.599	1.0
Vinyl Chloride	21-JAN-05 16:04	ND	0.375	1.0
Bromomethane	21-JAN-05 16:04	ND	0.316	1.0
Chloroethane	21-JAN-05 16:04	ND	0.400	1.0
Freon 11	21-JAN-05 16:04	ND	0.340	1.0
cis-1,2-Dichloroethene	21-JAN-05 16:04	ND	0.359	1.0
Carbon Disulfide	21-JAN-05 16:04	ND	0.330	1.0
Freon 113	21-JAN-05 16:04	ND	0.300	1.0
Acetone	21-JAN-05 16:04	ND	0.282	1.0
Methylene Chloride	21-JAN-05 16:04	ND	0.380	1.0
trans-1,2-Dichloroethene	21-JAN-05 16:04	ND	0.305	1.0
1,1-Dichloroethane	21-JAN-05 16:04	ND	0.336	1.0
Vinyl Acetate	21-JAN-05 16:04	ND	0.411	1.0
1,1-Dichloroethene	21-JAN-05 16:04	ND	0.362	1.0
2-Butanone	21-JAN-05 16:04	ND	0.439	1.0
Chloroform	21-JAN-05 16:04	ND	0.401	1.0
1,1,1-Trichloroethane	21-JAN-05 16:04	ND	0.337	1.0
Carbon Tetrachloride	21-JAN-05 16:04	ND	0.312	1.0
Benzene	21-JAN-05 16:04	ND	0.336	1.0
1,2-Dichloroethane	21-JAN-05 16:04	ND	0.362	1.0
Trichloroethene	21-JAN-05 16:04	ND	0.290	1.0
1,2-Dichloropropane	21-JAN-05 16:04	ND	0.362	1.0
Bromodichloromethane	21-JAN-05 16:04	ND	0.318	1.0
cis-1,3-Dichloropropene	21-JAN-05 16:04	ND	0.315	1.0
4-Methyl-2-Pentanone	21-JAN-05 16:04	ND	0.344	1.0
Toluene	21-JAN-05 16:04	ND	0.279	1.0
trans-1,3-Dichloropropene	21-JAN-05 16:04	ND	0.324	1.0
1,1,2-Trichloroethane	21-JAN-05 16:04	ND	0.296	1.0
Tetrachloroethene	21-JAN-05 16:04	ND	0.292	1.0
2-Hexanone	21-JAN-05 16:04	ND	0.347	1.0
Dibromochloromethane	21-JAN-05 16:04	ND	0.330	1.0
1,2-Dibromoethane	21-JAN-05 16:04	ND	0.313	1.0
Chlorobenzene	21-JAN-05 16:04	ND	0.293	1.0
Ethylbenzene	21-JAN-05 16:04	ND	0.311	1.0
m,p-Xylene	21-JAN-05 16:04	ND	0.708	1.0
o-Xylene	21-JAN-05 16:04	ND	0.361	1.0
Styrene	21-JAN-05 16:04	ND	0.296	1.0
Bromoform	21-JAN-05 16:04	ND	0.343	1.0
1,1,2,2-Tetrachloroethane	21-JAN-05 16:04	ND	0.329	1.0
Benzyl Chloride	21-JAN-05 16:04	ND	0.329	1.0
4-Ethyl toluene	21-JAN-05 16:04	ND	0.365	1.0
1,3,5-Trimethylbenzene	21-JAN-05 16:04	ND	0.343	1.0
1,2,4-Trimethylbenzene	21-JAN-05 16:04	ND	0.343	1.0
1,3-Dichlorobenzene	21-JAN-05 16:04	ND	0.328	1.0
1,4-Dichlorobenzene	21-JAN-05 16:04	ND	0.325	1.0

960 West LeVoy Drive / Salt Lake City, Utah 84123-2547  
Phone (801) 266-7700 Web Page: www.datachem.com  
FAX (801) 268-9992 E-mail: lab@datachem.com



FORM C (TYPE I)  
SINGLE METHOD ANALYSES

Form RLIMS63C-V1.4  
01260516204292  
Page 13

QUALITY CONTROL DATA SHEET  
BLANK SAMPLE



Client Name : Montana Tech

DCL Sample Name : BL-227387-1  
Date Printed : 26-JAN-05 16:20

Analytical Results

Analyte	Date Analyzed	Result	MDL	CRDL
1,2-Dichlorobenzene	21-JAN-05 16:04	ND	0.331	1.0
1,2,4-Trichlorobenzene	21-JAN-05 16:04	ND	0.352	1.0
Hexachlorobutadiene	21-JAN-05 16:04	ND	0.338	1.0
Methyl t-Butyl Ether	21-JAN-05 16:04	ND	0.316	1.0

960 West LeVoy Drive / Salt Lake City, Utah 84123-2547  
Phone (801) 266-7700 Web Page: [www.datachem.com](http://www.datachem.com)  
FAX (801) 268-9992 E-mail: [lab@datachem.com](mailto:lab@datachem.com)





FORM G (TYPE I)  
SINGLE METHOD ANALYSES

Form RLIMS63G-V1.4  
01260516204292  
Page 14

QUALITY CONTROL DATA SHEET  
SURROGATE SUMMARY



Client Name : Montana Tech  
Release Number : Not Provided  
Matrix : AIR  
Reporting Units : ppb v/v

Date Printed : 26-JAN-05 16:20  
DCL Analysis Group: G050R00G  
Analysis Method : TO15  
DCL Prep Group : Not Applicable  
Preparation Method: Not Applicable  
QC Limit Type : Method

Surrogate Recoveries

Surr. ID	4-Bromofluorobenzene								
QC Limits	65.0/135.								
DCL Sample Number	Analyte Result	Spiked Amount	% Rec.	Analyte Result	Spiked Amount	% Rec.	Analyte Result	Spiked Amount	% Rec.
05I01380	21.1	20.0	105.						
05I01381	17.9	20.0	89.3						
05I01382	19.4	20.0	96.8						
05I01383	19.2	20.0	96.2						
BL-227387-1	16.6	20.0	82.9						
QC-227387-1	19.6	20.0	98.1						
QD-227387-1	19.1	20.0	95.5						

960 West LeVoy Drive / Salt Lake City, Utah 84123-2547  
Phone (801) 266-7700 Web Page: www.datachem.com  
FAX (801) 268-9992 E-mail: lab@datachem.com



**DATA  
CHEM**  
LABORATORIES, INC.

**ANALYTICAL REQUEST FORM**

1.  REGULAR Status *DSI DIRECT*  
 RUSH Status Requested - ADDITIONAL CHARGE  
 RESULTS REQUIRED BY \_\_\_\_\_ DATE \_\_\_\_\_  
 CONTACT DATACHEM LABS PRIOR TO SENDING SAMPLES

2. Date 11/12/05 Purchase Order No. \_\_\_\_\_ 4. Quote No. \_\_\_\_\_  
 3. Company Name Montana Tech DCL Project Manager \_\_\_\_\_  
 Address 1300 West Pauli St.  
Butte MT 59701 5. Sample Collection  
 Person to Contact Terry Spear Sampling Site \_\_\_\_\_  
 Telephone (406) 496-1445 Industrial Process \_\_\_\_\_  
 Fax Telephone (406) 496-9650 Date of Collection \_\_\_\_\_  
 E-mail Address T.Spear@mttech.edu Time Collected \_\_\_\_\_  
 Billing Address (if different from above) Date of Shipment \_\_\_\_\_  
 Chain of Custody No. \_\_\_\_\_

**6. REQUEST FOR ANALYSES**

Laboratory Use Only	Client Sample Number	Matrix*	Sample Volume	ANALYSES REQUESTED - Use method number if known	Units**
	1156	Filter	662.4 L	gravimetric	
	1157	Filter	399.4 L	gravimetric	
	1166	Filter	635.1 L	gravimetric	
	1167	Filter	303.4 L	gravimetric	
	1176	Filter	712.2 L	gravimetric	
	1177	Filter	682.5 L	gravimetric	
<i>DSI 1380</i>	116 G	Miscan		EPA Method TO 15 + TPH	
<i>81</i>	116 SM	Miscan		EPA Method TO 15 + TPH	
<i>82</i>	117 G	Miscan		EPA Method TO 15 + TPH	
	118 BQ	Quota	200.0 L	FL/OC Method 50 VU	
	118 BG	Filter	400.0 L	gravimetric	

\* Specify: Solid sorbent tube, e.g. Charcoal; Filter type; Impinger solution; Bulk sample; Blood; Urine; Tissue; Soil; Water; Other  
 \*\* 1 ug/sample 2 mg/m<sup>3</sup> 3. ppm 4 % 5 \_\_\_\_\_ (other) Please indicate one or more units in the column entitled Units\*\*

Comments \_\_\_\_\_

Possible Contamination and/or Chemical Hazards \_\_\_\_\_

**7. Chain of Custody (Optional)**

Relinquished by _____	Date/Time _____
Received by <u>R. Pott</u>	Date/Time <u>1/20</u>
Relinquished by <u>R. Pott</u>	Date/Time <u>1/20</u>
Received by _____	Date/Time _____
Relinquished by _____	Date/Time _____
Received by _____	Date/Time _____

960 West LeVoy Drive / Salt Lake City, UT 84123 800-356-9135 or 801-266-7700 / FAX: 801-268-9992  
 DATACHEM LABORATORIES, INC. www.datachem.com



**DATA  
CHEM**  
LABORATORIES, INC.

### ANALYTICAL REQUEST FORM

1.  REGULAR Status 051-0107-07  
 RUSH Status Requested - ADDITIONAL CHARGE  
 RESULTS REQUIRED BY \_\_\_\_\_ DATE \_\_\_\_\_  
 CONTACT DATACHEM LABS PRIOR TO SENDING SAMPLES

2. Date 1/18/05 Purchase Order No. \_\_\_\_\_ 4. Quote No. \_\_\_\_\_  
 3. Company Name Manfang Tech DCL Project Manager \_\_\_\_\_  
 Address 1300 West Park St 5. Sample Collection \_\_\_\_\_  
6-11th MI 59701 Sampling Site \_\_\_\_\_  
 Person to Contact Terry Spow Industrial Process \_\_\_\_\_  
 Telephone (406) 496-4443 Date of Collection \_\_\_\_\_  
 Fax Telephone (406) 496-4650 Time Collected \_\_\_\_\_  
 E-mail Address T.Spow@mtch.edu Date of Shipment \_\_\_\_\_  
 Billing Address (if different from above) Chain of Custody No. \_\_\_\_\_

**6. REQUEST FOR ANALYSES**

Laboratory Use Only	Client Sample Number	Matrix*	Sample Volume	ANALYSES REQUESTED - Use method number if known	Units**
	118 BC	Charcoal	1000.0 ML	Method 1501	
	118 X	XAD-2	800.0 ML	Method 2539	
	118 NO2	Mol. sieve	750.0 ML	NO2 Method 6014	
	118 NO	Mol. sieve	850.0 ML	NO Method 6014	
<u>051-0107-05</u>	<u>#1 Mini Can</u>			<u>TO-15 + TPH.</u>	

\* Specify: Solid sorbent tube, e.g Charcoal; Filter type; Impinger solution; Bulk sample; Blood; Urine; Tissue; Soil; Water; Other  
 \*\* 1 ug/sample 2 mg/m<sup>3</sup> 3 ppm 4.% 5. \_\_\_\_\_ (other) Please indicate one or more units in the column entitled Units\*\*

Comments \_\_\_\_\_

Possible Contamination and/or Chemical Hazards \_\_\_\_\_

**7. Chain of Custody (Optional)**

Relinquished by _____	Date/Time _____
Received by <u>Rand Poth</u>	Date/Time <u>1/20</u>
Relinquished by <u>Rand Poth</u>	Date/Time <u>1/20</u>
Received by _____	Date/Time _____
Relinquished by _____	Date/Time _____
Received by _____	Date/Time _____

960 West LeVoy Drive / Salt Lake City, UT 84123  
 DATACHEM LABORATORIES, INC.

800-356-9135 or 801-266-7700 / FAX: 801-268-9992  
 www.datachem.com

FEB 23 2005



COVER PAGE  
ANALYTICAL REPORT FOR  
Montana Tech

Phone(406) 496-4445 Fax(406) 496-4650  
E-mail: tspear@mttech.edu

Form COVER-V1.4  
02220514274679  
Page 1



DCL Report Group.: 05I-0480-05

Date Printed.....: 22-FEB-05 14:27

Project Protocol #: P021C001  
Client Ref Number.: Not Provided  
Release Number.....: Not Provided

Analysis Method(s): TO-15

Montana Tech  
Attention: Terry Spear  
1300 West Park Street  
Butte, MT 59701

<u>Client Sample Name</u>	<u>Laboratory Sample Name</u>	<u>Date Sampled</u>	<u>Date Received</u>
MC27	05I04984	Not Provided	11-FEB-05
Method Blank	BL-228535-1	NA	NA
LCS	QC-228535-1	NA	NA
LCS Dup	QD-228535-1	NA	NA

*Andrea Hoggan* 2.22.05  
 Analyst: Andrea Hoggan Date  
*Thomas J. Mascian* 2.23.05  
 Reviewer: Thomas J. Mascian Date

960 West LeVoy Drive / Salt Lake City, Utah 84123-2547  
Phone (801) 266-7700 Web Page: www.datachem.com  
FAX (801) 268-9992 E-mail: lab@datachem.com



FORM H (TYPE I)  
SINGLE METHOD ANALYSES

Form RLIMS63H-V1.4  
02220514274679

Page 2

SAMPLE GROUP COMMENTS



DCL Report Group.: 05I-0480-05  
Date Printed.....: 22-FEB-05 14:27

Client Name...: Montana Tech

Release Number....: Not Provided

Sample Group Comments

The "E" qualifier indicates a reported level above the analytical linear range.  
Analyzed by GC/MS according to method T015.  
PQL - Practical Quantitation Limit - Lowest standard that is detectable.  
MDL - Method Detection Limit - Statistically derived value using 40 CFR methods.

General Information

The DCL QC Database maintains all numerical figures which are input from the pertinent data source. These data have not been rounded to significant figures nor have they been moisture corrected. Reports generated from the system, however, list data which have been rounded to the number of significant figures requested by the client or deemed appropriate for the method. This may create minor discrepancies between data which appear on the QC Summary Forms (Forms B-G) and those that would be calculated from rounded analytical results. Additionally, if a moisture correction is performed, differences will be observed between the QC data and the surrogate data reported on Form A (or other report forms) and corresponding data reported on QC Summary Forms. In these cases, the Form A will indicate the "Report Basis" as well as the moisture value used for making the correction.  
Report generation options: BX

Result Symbol Definitions

ND - Not Detected above the MDL (LLD or MDC for radiochemistry).  
\*\* - No result could be reported, see sample comments for details.

Qualifier Symbol Definitions

U - Not Detected above the MDL (LLD or MDC for radiochemistry).  
E - For organic analyses the qualifier indicates that this analyte was found in the method blank.  
F - For inorganic analyses the qualifier signifies the value is between the MDL and PQL.  
J - For organic analyses the qualifier indicates that the value is between the MDL and the PQL.  
It is also used for indicating an estimated value for tentatively identified compounds in mass spectrometry where a 1:1 response is assumed.

QC Flag Symbol Definitions

\* - Parameter outside of specified QC limits.

960 West LeVoy Drive / Salt Lake City, Utah 84123-2547  
Phone (801) 266-7700 Web Page: www.datachem.com  
FAX (801) 268-9992 E-mail: lab@datachem.com



FORM A (TYPE I)  
SINGLE METHOD ANALYSES

Form RLIMS63A-V1.4  
02220514274679  
Page 3

SAMPLE ANALYSIS DATA SHEET



Date Printed.....: 22-FEB-05 14:27  
Client Name.....: Montana Tech  
Client Ref Number.....: Not Provided  
Sampling Site.....: Not Provided  
Release Number.....: Not Provided  
Date Received.....: 11-FEB-05 00:00

Client Sample Name: MC27  
DCL Sample Name...: 05I04984  
DCL Report Group...: 05I-0400-05  
Matrix.....: AIR  
Date Sampled.....: Not Provided  
Reporting Units...: PPB V/V  
Report Basis.....:  As Received  Dried

DCL Preparation Group: Not Applicable  
Date Prepared.....: Not Applicable  
Preparation Method...: Not Applicable  
Aliquot Weight/Volume: 200 mL  
Net Weight/Volume....: Not Required

DCL Analysis Group: G051H01R  
Analysis Method...: TO-15  
Instrument Type...: GC/MS VO  
Instrument ID.....: 5972-0  
Column Type.....: DB-1  
 Primary  
 Confirmation

Analytical Results

Analyte	Date Analyzed	MDL	Result	Comment	Qual.	Dilution	PQL
Dichlorodifluoromethane	15-FEB-05 07:01	0.150	1.6			1	0.5
Chloromethane	15-FEB-05 07:01	0.187	1.5			1	0.5
Freon 114	15-FEB-05 07:01	0.155	ND			1	0.5
Vinyl Chloride	15-FEB-05 07:01	0.180	ND			1	0.5
Bromomethane	15-FEB-05 07:01	0.176	ND			1	0.5
Chloroethane	15-FEB-05 07:01	0.249	ND			1	0.5
Freon 11	15-FEB-05 07:01	0.132	0.35		J	1	0.5
cis-1,2-Dichloroethene	15-FEB-05 07:01	0.0938	ND			1	0.5
Carbon Disulfide	15-FEB-05 07:01	0.130	ND			1	0.5
Freon 113	15-FEB-05 07:01	0.124	ND			1	0.5
Acetone	15-FEB-05 07:42	0.179	270		E	10	0.5
Methylene Chloride	15-FEB-05 07:01	0.117	1.7			1	0.5
trans-1,2-Dichloroethene	15-FEB-05 07:01	0.100	ND			1	0.5
1,1-Dichloroethane	15-FEB-05 07:01	0.143	ND			1	0.5
1,1-Dichloroethane	15-FEB-05 07:01	0.0542	ND			1	0.5
Vinyl Acetate	15-FEB-05 07:01	0.105	ND			1	0.5
1,1-Dichloroethene	15-FEB-05 07:01	0.237	48.			10	0.5
2-Butanone	15-FEB-05 07:42	0.237	48.			10	0.5
Chloroform	15-FEB-05 07:01	0.127	0.17		J	1	0.5
1,1,1-Trichloroethane	15-FEB-05 07:01	0.122	ND			1	0.5
Carbon Tetrachloride	15-FEB-05 07:01	0.161	ND			1	0.5
Benzene	15-FEB-05 07:01	0.0939	2.2			1	0.5
1,2-Dichloroethane	15-FEB-05 07:01	0.101	ND			1	0.5
Trichloroethene	15-FEB-05 07:01	0.109	0.26		J	1	0.5
1,2-Dichloropropane	15-FEB-05 07:01	0.0669	ND			1	0.5
Bromodichloromethane	15-FEB-05 07:01	0.138	ND			1	0.5
cis-1,3-Dichloropropene	15-FEB-05 07:01	0.0979	ND			1	0.5
4-Methyl-2-Fentanone	15-FEB-05 07:01	0.0747	1.7			1	0.5
Toluene	15-FEB-05 07:01	0.120	7.1			1	0.5
trans-1,3-Dichloropropene	15-FEB-05 07:01	0.0788	ND			1	0.5
1,1,2-Trichloroethane	15-FEB-05 07:01	0.174	ND			1	0.5
Tetrachloroethene	15-FEB-05 07:01	0.117	0.50			1	0.5
2-Hexanone	15-FEB-05 07:01	0.0887	ND			1	0.5
Dibromochloromethane	15-FEB-05 07:01	0.125	ND			1	0.5
1,2-Dibromoethane	15-FEB-05 07:01	0.117	ND			1	0.5
Chlorobenzene	15-FEB-05 07:01	0.118	ND			1	0.5
Ethylbenzene	15-FEB-05 07:01	0.0872	11.			1	0.5
m,p-Xylene	15-FEB-05 07:01	0.215	30.			1	1.0
o-Xylene	15-FEB-05 07:01	0.103	7.5			1	0.5
Styrene	15-FEB-05 07:01	0.0625	0.46		J	1	0.5
Bromoform	15-FEB-05 07:01	0.118	ND			1	0.5
1,1,2,2-Tetrachloroethane	15-FEB-05 07:01	0.140	ND			1	0.5

960 West LeVoy Drive / Salt Lake City, Utah 84123-2547  
Phone (801) 266-7700 Web Page: www.datachem.com  
FAX (801) 268-9992 E-mail: lab@datachem.com



FORM A (TYPE I)  
SINGLE METHOD ANALYSES

Form RLIMS63A-V1.4  
02220514274679  
Page 4

SAMPLE ANALYSIS DATA SHEET



Date Printed.....: 22-FEB-05 14:27  
Client Name.....: Montana Tech

DCL Sample Name...: 05I04984  
DCL Report Group...: 05I-0480-05

Analytical Results

Analyte	Date Analyzed	MDL	Result	Comment	Qual.	Dilution	FOL
Benzyl Chloride	15-FEB-05 07:01	0.0856	ND			1	0.5
4-Ethyl toluene	15-FEB-05 07:01	0.0888	0.72			1	0.5
1,3,5-Trimethylbenzene	15-FEB-05 07:01	0.0592	1.2			1	0.5
1,2,4-Trimethylbenzene	15-FEB-05 07:01	0.0756	3.1			1	0.5
1,3-Dichlorobenzene	15-FEB-05 07:01	0.133	ND			1	0.5
1,4-Dichlorobenzene	15-FEB-05 07:01	0.133	0.24		J	1	0.5
1,2-Dichlorobenzene	15-FEB-05 07:01	0.107	ND			1	0.5
1,2,4-Trichlorobenzene	15-FEB-05 07:01	0.149	ND			1	0.5
Hexachlorobutadiene	15-FEB-05 07:01	0.232	ND			1	0.5
Methyl t-Butyl Ether	15-FEB-05 07:01	0.111	ND			1	0.5

Tentatively Identified Compound Results

Analyte(Retention Time)	Date Analyzed	Result	Comment	Qual.	Dilution
Propene(4.49)	15-FEB-05 07:01	67.		E	1
Isobutane(4.83)	15-FEB-05 07:01	5.5		J	1
Butane(5.07)	15-FEB-05 07:01	7.7		J	1
Silane, fluorotrimethyl-(5.19)	15-FEB-05 07:01	8.6		J	1
Ethanol(5.88)	15-FEB-05 07:01	110		E	1
Isopropyl Alcohol(6.46)	15-FEB-05 07:01	85.		E	1
methane, dimethoxy-(6.62)	15-FEB-05 07:01	3.7		J	1
Silane, (2-methoxyethyl)trimeth(7.62)	15-FEB-05 07:01	56.		J	1
Silanol, trimethyl-(7.84)	15-FEB-05 07:01	56.		J	1
Hexane(8.51)	15-FEB-05 07:01	2.9			1
Ethyl Acetate(8.54)	15-FEB-05 07:01	1.6			1
CYCLOPENTANE, METHYL-(9.21)	15-FEB-05 07:01	2.5		J	1
6H-Purin-6-one,2-amino-1,7-dih(9.56)	15-FEB-05 07:01	3.6		J	1
Pentane, 2,3-dimethyl-(10.24)	15-FEB-05 07:01	2.4		J	1
Hexane, 3-methyl-(10.38)	15-FEB-05 07:01	3.8		J	1
Heptane(10.95)	15-FEB-05 07:01	2.4			1
2-Pentene, 2,3-dimethyl-(12.92)	15-FEB-05 07:01	2.4		J	1
2-Heptanone(14.80)	15-FEB-05 07:01	2.6		J	1
Nonane(15.34)	15-FEB-05 07:01	2.7		J	1
Nonane, 3-methyl-(16.04)	15-FEB-05 07:01	2.7		J	1
Decane(17.22)	15-FEB-05 07:01	6.1		J	1
C10 Aromatic(17.66)	15-FEB-05 07:01	5.9		J	1
Limonene(17.84)	15-FEB-05 07:01	8.3		J	1
Cyclohexane, (1-methylpropyl)-(17.97)	15-FEB-05 07:01	2.6		J	1
Undecane(18.93)	15-FEB-05 07:01	4.7		J	1

960 West LeVoy Drive / Salt Lake City, Utah 84123-2547  
Phone (801) 266-7700 Web Page: www.datachem.com  
FAX (801) 268-9992 E-mail: lab@datachem.com



FORM J (TYPE I)  
SINGLE METHOD ANALYSES

Form RLIMS63J-V1.4  
02220514274679  
Page 5

QUALITY CONTROL DATA SHEET  
LABORATORY CONTROL SAMPLE (LCS)  
LABORATORY CONTROL DUPL (LCD)



S051G01Q

Client Name.....: Montana Tech  
Release Number.....: Not Provided

DCL Sample Name...: QC-228535-1  
Date Printed.....: 22-FEB-05 14:27

Matrix.....: AIR  
Reporting Units.....: ppb v/v

DCL Analysis Group: G051H01R  
Analysis Method...: T015  
Instrument Type...: GC/MS VO  
Instrument ID.....: 5972-0  
Column Type.....: DB-1

DCL Preparation Group: Not Applicable  
Date Prepared.....: Not Applicable  
Preparation Method...: Not Applicable

Primary  
 Confirmation

QC Limit Type.....: Method

Analytical Results

Analyte	Date Analyzed	Target	Result	Percent Recovery	QC Limits	QC Flag
Vinyl Chloride	14-FEB-05 12:07	10.0	11.5	115.	70.0/130.	
cis-1,2-Dichloroethene	14-FEB-05 12:07	10.0	8.14	81.4	70.0/130.	
Methylene Chloride	14-FEB-05 12:07	10.0	9.22	92.2	70.0/130.	
trans-1,2-Dichloroethene	14-FEB-05 12:07	10.0	8.89	88.9	70.0/130.	
1,1-Dichloroethane	14-FEB-05 12:07	10.0	9.41	94.1	70.0/130.	
1,1-Dichloroethene	14-FEB-05 12:07	10.0	8.84	88.4	70.0/130.	
Chloroform	14-FEB-05 12:07	10.0	8.31	83.1	70.0/130.	
1,1,1-Trichloroethane	14-FEB-05 12:07	10.0	9.38	93.8	70.0/130.	
Carbon Tetrachloride	14-FEB-05 12:07	10.0	8.97	89.7	70.0/130.	
Benzene	14-FEB-05 12:07	10.0	8.98	89.8	70.0/130.	
1,2-Dichloroethane	14-FEB-05 12:07	10.0	9.15	91.5	70.0/130.	
Trichloroethene	14-FEB-05 12:07	10.0	9.87	98.7	70.0/130.	
1,2-Dichloropropane	14-FEB-05 12:07	10.0	10.0	100.	70.0/130.	
Toluene	14-FEB-05 12:07	10.0	9.74	97.4	70.0/130.	
trans-1,3-Dichloropropene	14-FEB-05 12:07	10.0	8.72	87.2	70.0/130.	
1,1,2-Trichloroethane	14-FEB-05 12:07	10.0	9.49	94.9	70.0/130.	
Tetrachloroethane	14-FEB-05 12:07	10.0	9.18	91.8	70.0/130.	
1,2-Dibromoethane	14-FEB-05 12:07	10.0	9.47	94.7	70.0/130.	
Ethylbenzene	14-FEB-05 12:07	10.0	8.99	89.9	70.0/130.	
m,p-Xylene	14-FEB-05 12:07	20.0	16.8	84.2	70.0/130.	
o-Xylene	14-FEB-05 12:07	10.0	9.06	90.7	70.0/130.	
Styrene	14-FEB-05 12:07	10.0	8.58	85.8	70.0/130.	
1,1,1,2-Tetrachloroethane	14-FEB-05 12:07	10.0	8.94	89.4	70.0/130.	
Ethanol	14-FEB-05 12:07	10.0	11.3	113.	70.0/130.	



S051G01R

DCL Sample Name...: QD-228535-1

Analytical Results

Analyte	Date Analyzed	Duplicate Result	Percent Recovery	Mean	Range	RPD	QC Limits	QC Flag
Vinyl Chloride	14-FEB-05 12:52	11.9	119.	11.7	0.319	2.7	0.00/25.0	
cis-1,2-Dichloroethene	14-FEB-05 12:52	8.72	87.2	8.43	0.588	7.0	0.00/25.0	
Methylene Chloride	14-FEB-05 12:52	9.27	92.7	9.25	0.0450	0.49	0.00/25.0	
trans-1,2-Dichloroethene	14-FEB-05 12:52	9.63	96.3	9.26	0.742	8.0	0.00/25.0	
1,1-Dichloroethane	14-FEB-05 12:52	9.69	96.9	9.55	0.287	3.0	0.00/25.0	
1,1-Dichloroethene	14-FEB-05 12:52	9.25	92.5	9.05	0.418	4.6	0.00/25.0	
Chloroform	14-FEB-05 12:52	9.13	91.3	8.72	0.817	9.4	0.00/25.0	
1,1,1-Trichloroethane	14-FEB-05 12:52	9.32	93.3	9.35	0.0520	0.56	0.00/25.0	
Carbon Tetrachloride	14-FEB-05 12:52	9.13	91.3	9.05	0.161	1.8	0.00/25.0	
Benzene	14-FEB-05 12:52	9.81	98.1	9.39	0.829	8.8	0.00/25.0	
1,2-Dichloroethane	14-FEB-05 12:52	9.30	93.0	9.23	0.146	1.6	0.00/25.0	

960 West LeVoy Drive / Salt Lake City, Utah 84123-2547  
Phone (801) 266-7700  
FAX (801) 268-9992  
Web Page: www.datachem.com  
E-mail: lab@datachem.com





FORM J (TYPE I)  
SINGLE METHOD ANALYSES  
QUALITY CONTROL DATA SHEET  
LABORATORY CONTROL SAMPLE (LCS)  
LABORATORY CONTROL DUPL (LCD)

Form RLIMS63J-V1.4  
02220514274679  
Page 6



Client Name.....: Montana Tech

DCL Sample Name...: QD-220535-1  
Date Printed.....: 22-FEB-05 14:27

Analytical Results

Analyte	Date Analyzed	Duplicate Result	Percent Recovery	Mean	Range	RPD	QC Limits	QC Flag
Trichloroethene	14-FEB-05 12:52	11.0	110.	10.4	1.12	11.	0.00/25.0	
1,2-Dichloropropane	14-FEB-05 12:52	10.3	103.	10.2	0.326	3.2	0.00/25.0	
Toluene	14-FEB-05 12:52	9.26	92.6	9.50	0.483	5.1	0.00/25.0	
trans-1,3-Dichloropropene	14-FEB-05 12:52	9.92	99.2	9.32	1.20	13.	0.00/25.0	
1,1,2-Trichloroethane	14-FEB-05 12:52	8.94	89.4	9.21	0.551	6.0	0.00/25.0	
Tetrachloroethene	14-FEB-05 12:52	8.23	82.3	8.70	0.953	11.	0.00/25.0	
1,2-Dibromoethane	14-FEB-05 12:52	9.28	92.8	9.38	0.185	2.0	0.00/25.0	
Ethylbenzene	14-FEB-05 12:52	9.28	92.8	9.14	0.266	3.1	0.00/25.0	
m,p-Xylene	14-FEB-05 12:52	17.7	88.3	17.2	0.828	4.8	0.00/25.0	
o-Xylene	14-FEB-05 12:52	9.46	94.6	9.26	0.395	4.3	0.00/25.0	
Styrene	14-FEB-05 12:52	8.45	84.5	8.52	0.131	1.5	0.00/25.0	
1,1,2,2-Tetrachloroethane	14-FEB-05 12:52	8.72	87.2	8.83	0.216	2.4	0.00/25.0	
Ethanol	14-FEB-05 12:52	12.0	120.	11.6	0.670	5.8	0.00/25.0	

960 West LeVoy Drive / Salt Lake City, Utah 84123-2547  
Phone (801) 266-7700 Web Page: www.datachem.com  
FAX (801) 268-9992 E-mail: lab@datachem.com



FORM C (TYPE I)  
SINGLE METHOD ANALYSES

Form RLIMS63C-V1.4  
02220514274679  
Page 7

QUALITY CONTROL DATA SHEET  
BLANK SAMPLE



Client Name.....: Montana Tech  
Release Number.....: Not Provided

DCL Sample Name...: BE-228535-1  
Date Printed.....: 22-FEB-05 14:27

Matrix.....: AIR  
Reporting Units.....: PPB V/V

DCL Analysis Group: G051H01R  
Analysis Method...: TO-15  
Instrument Type...: GC/MS VO  
Instrument ID.....: 5972-0  
Column Type.....: DB-1

DCL Preparation Group: Not Applicable  
Date Prepared.....: Not Applicable  
Preparation Method...: Not Applicable

Primary  
 Confirmation

QC Limit Type.....: Method

Analytical Results

Analyte	Date Analyzed	Result	MDL	CRDL
Dichlorodifluoromethane	14-FEB-05 13:35	ND	0.150	0.5
Chloromethane	14-FEB-05 13:35	ND	0.187	0.5
Freon 114	14-FEB-05 13:35	ND	0.155	0.5
Vinyl Chloride	14-FEB-05 13:35	ND	0.180	0.5
Bromomethane	14-FEB-05 13:35	ND	0.176	0.5
Chloroethane	14-FEB-05 13:35	ND	0.249	0.5
Freon 11	14-FEB-05 13:35	ND	0.132	0.5
cis-1,2-Dichloroethene	14-FEB-05 13:35	ND	0.0938	0.5
Carbon Disulfide	14-FEB-05 13:35	ND	0.130	0.5
Freon 113	14-FEB-05 13:35	ND	0.124	0.5
Acetone	14-FEB-05 13:35	ND	0.179	0.5
Methylene Chloride	14-FEB-05 13:35	ND	0.117	0.5
trans-1,2-Dichloroethene	14-FEB-05 13:35	ND	0.100	0.5
1,1-Dichloroethane	14-FEB-05 13:35	ND	0.143	0.5
Vinyl Acetate	14-FEB-05 13:35	ND	0.0642	0.5
1,1-Dichloroethene	14-FEB-05 13:35	ND	0.105	0.5
2-Butanone	14-FEB-05 13:35	ND	0.237	0.5
Chloroform	14-FEB-05 13:35	ND	0.127	0.5
1,1,1-Trichloroethane	14-FEB-05 13:35	ND	0.122	0.5
Carbon Tetrachloride	14-FEB-05 13:35	ND	0.161	0.5
Benzene	14-FEB-05 13:35	ND	0.0939	0.5
1,2-Dichloroethane	14-FEB-05 13:35	ND	0.101	0.5
Trichloroethene	14-FEB-05 13:35	ND	0.109	0.5
1,2-Dichloropropane	14-FEB-05 13:35	ND	0.0669	0.5
Bromodichloromethane	14-FEB-05 13:35	ND	0.138	0.5
cis-1,3-Dichloropropene	14-FEB-05 13:35	ND	0.0979	0.5
4-Methyl-2-Pentanone	14-FEB-05 13:35	ND	0.0747	0.5
Toluene	14-FEB-05 13:35	ND	0.120	0.5
trans-1,3-Dichloropropene	14-FEB-05 13:35	ND	0.0788	0.5
1,1,2-Trichloroethane	14-FEB-05 13:35	ND	0.174	0.5
Tetrachloroethene	14-FEB-05 13:35	ND	0.117	0.5
2-Hexanone	14-FEB-05 13:35	ND	0.0887	0.5
Dibromochloromethane	14-FEB-05 13:35	ND	0.125	0.5
1,2-Dibromoethane	14-FEB-05 13:35	ND	0.117	0.5
Chlorobenzene	14-FEB-05 13:35	ND	0.119	0.5
Ethylbenzene	14-FEB-05 13:35	ND	0.0872	0.5
m,p-Xylene	14-FEB-05 13:35	ND	0.215	1.0
o-Xylene	14-FEB-05 13:35	ND	0.103	0.5
Styrene	14-FEB-05 13:35	ND	0.0625	0.5
Bromoform	14-FEB-05 13:35	ND	0.118	0.5
1,1,1,2-Tetrachloroethane	14-FEB-05 13:35	ND	0.140	0.5
Benzyl Chloride	14-FEB-05 13:35	ND	0.0856	0.5
4-Ethyl toluene	14-FEB-05 13:35	ND	0.0888	0.5
1,3,5-Trimethylbenzene	14-FEB-05 13:35	ND	0.0592	0.5
1,2,4-Trimethylbenzene	14-FEB-05 13:35	ND	0.0756	0.5
1,3-Dichlorobenzene	14-FEB-05 13:35	ND	0.133	0.5
1,4-Dichlorobenzene	14-FEB-05 13:35	ND	0.133	0.5

960 West LeVoy Drive / Salt Lake City, Utah 84123-2547  
Phone (801) 266-7700 Web Page: www.datachem.com  
FAX (801) 268-9992 E-mail: lab@datachem.com



FORM C (TYPE I)  
SINGLE METHOD ANALYSES

Form RLIMS63C-V1.4  
02220514274679  
Page 8

QUALITY CONTROL DATA SHEET  
BLANK SAMPLE



Client Name.....: Montana Tech

DCL Sample Name...: BL-220535-1  
Date Printed.....: 22-FEB-05 14:27

Analytical Results

Analyte	Date Analyzed	Result	MDL	CRDL
1,2-Dichlorobenzene	14-FEB-05 13:35	ND	0.107	0.5
1,2,4-Trichlorobenzene	14-FEB-05 13:35	ND	0.149	0.5
Hexachlorobutadiene	14-FEB-05 13:35	ND	0.232	0.5
Methyl t-Butyl Ether	14-FEB-05 13:35	ND	0.111	0.5

960 West LeVoy Drive / Salt Lake City, Utah 84123-2547  
Phone (801) 266-7700 Web Page: www.datachem.com  
FAX (801) 268-9992 E-mail: lab@datachem.com



FORM G (TYPE I)  
SINGLE METHOD ANALYSES

Form RLIMS63G-V1.4  
02220514274679  
Page 9

QUALITY CONTROL DATA SHEET  
SURROGATE SUMMARY



Client Name.....: Montana Tech  
Release Number.....: Not Provided  
  
Matrix.....: AIR  
Reporting Units.....: ppb v/v

Date Printed.....: 22-FEB-05 14:27  
  
DCL Analysis Group: G051H01R  
Analysis Method...: T015  
  
DCL Prep Group....: Not Applicable  
Preparation Method: Not Applicable  
  
QC Limit Type.....: Method

Surrogate Recoveries

Surr. ID	4-Bromofluorobenzene								
QC Limits	65.0/135.								
DCL Sample Number	Analyte Result	Spiked Amount	% Rec. Q	Analyte Result	Spiked Amount	% Rec. Q	Analyte Result	Spiked Amount	% Rec. Q
05I04984	16.4	20.0	82.2						
BL-228535-1	17.3	20.0	86.5						
QC-228535-1	20.1	20.0	100.						
QD-228535-1	19.7	20.0	98.7						

960 West LeVoy Drive / Salt Lake City, Utah 84123-2547  
Phone (801) 266-7700 Web Page: www.datachem.com  
FAX (801) 268-9992 E-mail: iab@datachem.com



**DATA  
CHEM**  
LABORATORIES, INC.

### ANALYTICAL REQUEST FORM

1.  REGULAR Status 051-048005

RUSH Status Requested - ADDITIONAL CHARGE  
 RESULTS REQUIRED BY \_\_\_\_\_ DATE \_\_\_\_\_  
 CONTACT DATACHEM LABS PRIOR TO SENDING SAMPLES

2. Date 2/9/05 Purchase Order No. \_\_\_\_\_ 4. Quote No. \_\_\_\_\_  
 3. Company Name Montana Tech DCL Project Manager \_\_\_\_\_  
 Address 1300 West Rock St 5. Sample Collection \_\_\_\_\_  
Butte MT 59701 Sampling Site \_\_\_\_\_  
 Person to Contact Terry Spear Industrial Process \_\_\_\_\_  
 Telephone (406) 496-4445 Date of Collection \_\_\_\_\_  
 Fax Telephone (406) 496-4650 Time Collected \_\_\_\_\_  
 E-mail Address TSpear@Mtech.edu Date of Shipment \_\_\_\_\_  
 Billing Address (if different from above) Chain of Custody No. \_\_\_\_\_

**6. REQUEST FOR ANALYSES**

Laboratory Use Only	Client Sample Number	Matrix*	Sample Volume	ANALYSES REQUESTED - Use method number if known	Units**
	273	Quartz Filt	457.24 L	EC/OC (MMAM 5040)	
	272	Quartz Filt	466.5 L	(MMAM 5040)	
	MG 2PY	ZF Filt	473.8 L	gravimetric (MMAM 5040)	
	MG 1PB	ZF Filt	486.9 L	gravimetric (MMAM 5040)	
			3490.5 cc		
	MK 27	Bil. can	<del>3590.5</del> cc	NO <sub>2</sub> (MMAM 6014)	
	MMX 27		3490.5 cc	NO (MMAM 6014)	
	M 27	Charcoal	35,953 cc	BET <sub>N</sub> and total HC (MMAM 501)	
	MX 27	XAD	8228.6 cc	Aldehyde screen (MMAM 2529)	
<u>DE 0494</u>	MC 27	Min. can		VOC screen EPA 1015 (K275)	

\* Specify: Solid sorbent tube, e.g. Charcoal; Filter type; Impinger solution; Bulk sample; Blood; Urine; Tissue; Soil; Water; Other  
 \*\* 1. ug/sample 2 mg/m<sup>3</sup> 3 ppm 4 % 5 \_\_\_\_\_ (other) Please indicate one or more units in the column entitled Units\*\*

Comments \_\_\_\_\_

Possible Contamination and/or Chemical Hazards \_\_\_\_\_

**7. Chain of Custody (Optional)**

Relinquished by _____	Date/Time _____
Received by <u>R. [Signature]</u>	Date/Time <u>2/11</u>
Relinquished by _____	Date/Time _____
Received by _____	Date/Time _____
Relinquished by _____	Date/Time _____
Received by _____	Date/Time _____

960 West LeVoy Drive / Salt Lake City, UT 84123  
 DATACHEM LABORATORIES, INC.

800-356-9135 or 801-266-7700 / FAX: 801-268-9992  
 www.datachem.com



COVER PAGE

MAR 07 2005

ANALYTICAL REPORT FOR  
Montana Tech

Phone (406) 496-4445 Fax (406) 496-4650  
E-mail: tspear@ntech.edu

Form COVER-V1.4  
03050512360228  
Page 1



DCL Report Group : 05I-0676-06

Date Printed : 05-MAR-05 12:36

Project Protocol #: P021C001  
Client Ref Number: Not Provided  
Release Number: Not Provided

Analysis Method(s): TO-15

Montana Tech  
Attention: Terry Spear  
1300 West Park Street  
Butte, MT 59701

<u>Client Sample Name</u>	<u>Laboratory Sample Name</u>	<u>Date Sampled</u>	<u>Date Received</u>
Method Blank	BL-229040-1	NA	NA
LCS	QC-229040-1	NA	NA
LCS Dup	QD-229040-1	NA	NA
219KA 108527	05I06987	Not Provided	25-FEB-05
2190B 108757	05I06988	Not Provided	25-FEB-05
220KA 108836	05I06989	Not Provided	25-FEB-05
220R 108964	05I06990	Not Provided	25-FEB-05
222KA 108966	05I06991	Not Provided	25-FEB-05
222AI 108768	05I06992	Not Provided	25-FEB-05

*Andrea Hoggan* 3.5.05  
Analyst: Andrea Hoggan Date  
*Thomas J. Masolian* 3.7.05  
Reviewer: Thomas J. Masolian Date

960 West LeVoy Drive / Salt Lake City, Utah 84123-2547  
Phone (801) 266-7700 Web Page: www.datachem.com  
FAX (801) 268-9992 E-mail: lab@datachem.com



FORM H (TYPE I)  
SINGLE METHOD ANALYSES

Form RLIMS63H-V1.4  
03050512360228  
Page 2

SAMPLE GROUP COMMENTS



G051W00P

DCL Report Group : 051-0676-06  
Date Printed : 05-MAR-05 12:36

Client Name : Montana Tech

Release Number : Not Provided

Sample Group Comments

The "E" qualifier indicates a reported level above the analytical linear range Analyzed by GC/MS according to method T015  
PQL - Practical Quantitation Limit - Lowest standard that is detectable  
MDL - Method Detection Limit - Statistically derived value using 40 CFR methods

General Information

The DCL QC Database maintains all numerical figures which are input from the pertinent data source. These data have not been rounded to significant figures nor have they been moisture corrected. Reports generated from the system, however, list data which have been rounded to the number of significant figures requested by the client or deemed appropriate for the method. This may create minor discrepancies between data which appear on the QC Summary Forms (Forms B-G) and those that would be calculated from rounded analytical results. Additionally, if a moisture correction is performed, differences will be observed between the QC data and the surrogate data reported on Form A (or other report forms) and corresponding data reported on QC Summary Forms. In these cases, the Form A will indicate the "Report Basis" as well as the moisture value used for making the correction.  
Report generation options: BX

Result Symbol Definitions

ND - Not Detected above the MDL (LLD or MDC for radiochemistry).  
\*\* - No result could be reported, see sample comments for details.

Qualifier Symbol Definitions

U - Not Detected above the MDL (LLD or MDC for radiochemistry).  
B - For organic analyses the qualifier indicates that this analyte was found in the method blank.  
For inorganic analyses the qualifier signifies the value is between the MDL and PQL.  
J - For organic analyses the qualifier indicates that the value is between the MDL and the PQL.  
It is also used for indicating an estimated value for tentatively identified compounds in mass spectrometry where a 1:1 response is assumed.

QC Flag Symbol Definitions

\* - Parameter outside of specified QC limits.

960 West LeVoy Drive / Salt Lake City, Utah 84123-2547  
Phone (801) 266-7700 Web Page: www.datachem.com  
FAX (801) 268-9992 E-mail: lab@datachem.com



FORM A (TYPE I)  
SINGLE METHOD ANALYSES

Form RLIMS63A-V1.4  
03050512360228  
Page 3

SAMPLE ANALYSIS DATA SHEET



S051W01X

Date Printed : 05-MAR-05 12:36  
Client Name : Montana Tech  
Client Ref Number : Not Provided  
Sampling Site : Not Provided  
Release Number : Not Provided  
Date Received : 25-FEB-05 00:00

Client Sample Name: 219KA|108527  
DCL Sample Name : 05I06987  
DCL Report Group : 05I-0676-06  
Matrix : AIR  
Date Sampled : Not Provided  
Reporting Units : PPB V/V  
Report Basis :  As Received  Dried

DCL Preparation Group: Not Applicable  
Date Prepared : Not Applicable  
Preparation Method : Not Applicable  
Aliquot Weight/Volume: 200 mL  
Net Weight/Volume : Not Required

DCL Analysis Group: G0523028  
Analysis Method : TO-15  
Instrument Type : GC/MS VO  
Instrument ID : 5972-0  
Column Type : DB-1  
 Primary  
 Confirmation

Analytical Results

Analyte	Date Analyzed	MDL	Result	Comment	Qual.	Dilution	FOL
Dichlorodifluoromethane	04-MAR-05 11:17	0.150	0.96			1	0.5
Chloromethane	04-MAR-05 11:17	0.187	1.5			1	0.5
Freon 114	04-MAR-05 11:17	0.155	ND			1	0.5
Vinyl Chloride	04-MAR-05 11:17	0.180	ND			1	0.5
Bromomethane	04-MAR-05 11:17	0.176	ND			1	0.5
Chloroethane	04-MAR-05 11:17	0.249	ND			1	0.5
Freon 11	04-MAR-05 11:17	0.132	0.80			1	0.5
cis-1,2-Dichloroethene	04-MAR-05 11:17	0.0938	ND			1	0.5
Carbon Disulfide	04-MAR-05 11:17	0.130	0.66			1	0.5
Freon 113	04-MAR-05 11:17	0.124	ND			1	0.5
Acetone	04-MAR-05 11:17	0.179	20.			1	0.5
Methylene Chloride	04-MAR-05 11:17	0.117	0.80			1	0.5
trans-1,2-Dichloroethene	04-MAR-05 11:17	0.100	ND			1	0.5
1,1-Dichloroethane	04-MAR-05 11:17	0.143	ND			1	0.5
Vinyl Acetate	04-MAR-05 11:17	0.0642	ND			1	0.5
1,1-Dichloroethene	04-MAR-05 11:17	0.105	ND			1	0.5
2-Butanone	04-MAR-05 11:17	0.237	3.6			1	0.5
Chloroform	04-MAR-05 11:17	0.127	0.60			1	0.5
1,1,1-Trichloroethane	04-MAR-05 11:17	0.122	ND			1	0.5
Carbon Tetrachloride	04-MAR-05 11:17	0.161	ND			1	0.5
Benzene	04-MAR-05 11:17	0.0939	1.4			1	0.5
1,2-Dichloroethane	04-MAR-05 11:17	0.101	ND			1	0.5
Trichloroethene	04-MAR-05 11:17	0.109	1.1			1	0.5
1,2-Dichloropropane	04-MAR-05 11:17	0.0669	ND			1	0.5
Bromodichloromethane	04-MAR-05 11:17	0.138	ND			1	0.5
cis-1,3-Dichloropropene	04-MAR-05 11:17	0.0979	ND			1	0.5
4-Methyl-2-Pentanone	04-MAR-05 11:17	0.0747	0.79			1	0.5
Toluene	04-MAR-05 11:17	0.120	4.3			1	0.5
trans-1,3-Dichloropropene	04-MAR-05 11:17	0.0788	ND			1	0.5
1,1,2-Trichloroethane	04-MAR-05 11:17	0.174	ND			1	0.5
Tetrachloroethene	04-MAR-05 11:17	0.117	0.52			1	0.5
2-Hexanone	04-MAR-05 11:17	0.0887	0.64			1	0.5
Dibromochloromethane	04-MAR-05 11:17	0.125	ND			1	0.5
1,2-Dibromoethane	04-MAR-05 11:17	0.117	ND			1	0.5
Chlorobenzene	04-MAR-05 11:17	0.118	ND			1	0.5
Ethylbenzene	04-MAR-05 11:17	0.0872	1.0			1	0.5
m,p-Xylene	04-MAR-05 11:17	0.215	3.5			1	1.0
o-Xylene	04-MAR-05 11:17	0.103	1.3			1	0.5
Styrene	04-MAR-05 11:17	0.0625	0.78			1	0.5
Bromoform	04-MAR-05 11:17	0.118	ND			1	0.5
1,1,2,2-Tetrachloroethane	04-MAR-05 11:17	0.140	ND			1	0.5

960 West LeVoy Drive / Salt Lake City, Utah 84123-2547  
Phone (801) 266-7700 Web Page: www.datachem.com  
FAX (801) 268-9992 E-mail: lab@datachem.com





FORM A (TYPE I)  
SINGLE METHOD ANALYSES

Form RLIMS63A-V1.4  
03050512360228  
Page 4

SAMPLE ANALYSIS DATA SHEET



Date Printed : 05-MAR-05 12:36  
Client Name : Montana Tech

DCL Sample Name : 05I06987  
DCL Report Group : 05I-0676-06

Analytical Results

Analyte	Date Analyzed	MDL	Result	Comment	Qual.	Dilution	PQL
Benzyl Chloride	04-MAR-05 11:17	0.0856	ND			1	0.5
4-Ethyl toluene	04-MAR-05 11:17	0.0888	0.88			1	0.5
1,3,5-Trimethylbenzene	04-MAR-05 11:17	0.0592	0.57			1	0.5
1,2,4-Trimethylbenzene	04-MAR-05 11:17	0.0756	1.0			1	0.5
1,3-Dichlorobenzene	04-MAR-05 11:17	0.133	ND			1	0.5
1,4-Dichlorobenzene	04-MAR-05 11:17	0.133	0.46		J	1	0.5
1,2-Dichlorobenzene	04-MAR-05 11:17	0.107	ND			1	0.5
1,2,4-Trichlorobenzene	04-MAR-05 11:17	0.149	ND			1	0.5
Hexachlorobutadiene	04-MAR-05 11:17	0.232	ND			1	0.5
Methyl t-Butyl Ether	04-MAR-05 11:17	0.111	ND			1	0.5
Total Petroleum Hydrocarbons	04-MAR-05 11:17		30.		J	1	

Tentatively Identified Compound Results

Analyte (Retention Time)	Date Analyzed	Result	Comment	Qual.	Dilution
Propene(4.48)	04-MAR-05 11:17	2.4			1
Acetaldehyde(4.84)	04-MAR-05 11:17	3.5		J	1
Butane(5.09)	04-MAR-05 11:17	2.8		J	1
Ethanol(5.68)	04-MAR-05 11:17	56.		E	1
Isopropyl Alcohol(6.26)	04-MAR-05 11:17	170		E	1
Pentane, 2-methyl-(7.79)	04-MAR-05 11:17	3.5		J	1
Hexane(8.51)	04-MAR-05 11:17	1.3			1
Ethyl Acetate(8.57)	04-MAR-05 11:17	1.2			1
Heptane(10.95)	04-MAR-05 11:17	1.2			1
Limonene(17.84)	04-MAR-05 11:17	5.7		J	1

960 West LeVoy Drive / Salt Lake City, Utah 84123-2547  
Phone (801) 266-7700 Web Page: www.datachem.com  
FAX (801) 268-9992 E-mail: lab@datachem.com



FORM A (TYPE I)  
SINGLE METHOD ANALYSES

Form RLIMS63A-V1.4  
03050512360228  
Page 5

SAMPLE ANALYSIS DATA SHEET



Date Printed : 05-MAR-05 12:36  
Client Name : Montana Tech  
Client Ref Number : Not Provided  
Sampling Site : Not Provided  
Release Number : Not Provided  
Date Received : 25-FEB-05 00:00

Client Sample Name: 2190B|108757  
DCL Sample Name : 05I06988  
DCL Report Group : 05I-0676-06  
Matrix : AIR  
Date Sampled : Not Provided  
Reporting Units : PPB V/V  
Report Basis :  As Received  Dried

DCL Preparation Group: Not Applicable  
Date Prepared : Not Applicable  
Preparation Method : Not Applicable  
Aliquot Weight/Volume: 200 mL  
Net Weight/Volume : Not Required

DCL Analysis Group: G0523028  
Analysis Method : TO-15  
Instrument Type : GC/MS VO  
Instrument ID : 5972-0  
Column Type : DB-1  
 Primary  
 Confirmation

Analytical Results

Analyte	Date Analyzed	MDL	Result	Comment	Qual.	Dilution	PQL
Dichlorodifluoromethane	04-MAR-05 11:55	0.150	0.45		J	1	0.5
Chloromethane	04-MAR-05 11:55	0.187	0.52			1	0.5
Freon 114	04-MAR-05 11:55	0.155	ND			1	0.5
Vinyl Chloride	04-MAR-05 11:55	0.180	ND			1	0.5
Bromomethane	04-MAR-05 11:55	0.176	ND			1	0.5
Chloroethane	04-MAR-05 11:55	0.249	ND			1	0.5
Freon 11	04-MAR-05 11:55	0.132	0.37		J	1	0.5
cis-1,2-Dichloroethene	04-MAR-05 11:55	0.0938	ND			1	0.5
Carbon Disulfide	04-MAR-05 11:55	0.130	0.35		J	1	0.5
Freon 113	04-MAR-05 11:55	0.124	ND			1	0.5
Acetone	04-MAR-05 11:55	0.179	8.8			1	0.5
Methylene Chloride	04-MAR-05 11:55	0.117	0.67			1	0.5
trans-1,2-Dichloroethene	04-MAR-05 11:55	0.100	ND			1	0.5
1,1-Dichloroethane	04-MAR-05 11:55	0.143	ND			1	0.5
Vinyl Acetate	04-MAR-05 11:55	0.0642	ND			1	0.5
1,1-Dichloroethene	04-MAR-05 11:55	0.105	ND			1	0.5
2-Butanone	04-MAR-05 11:55	0.237	ND			1	0.5
Chloroform	04-MAR-05 11:55	0.127	0.27		J	1	0.5
1,1,1-Trichloroethane	04-MAR-05 11:55	0.122	ND			1	0.5
Carbon Tetrachloride	04-MAR-05 11:55	0.161	ND			1	0.5
Benzene	04-MAR-05 11:55	0.0939	0.82			1	0.5
1,2-Dichloroethane	04-MAR-05 11:55	0.101	ND			1	0.5
Trichloroethene	04-MAR-05 11:55	0.109	0.26		J	1	0.5
1,2-Dichloropropane	04-MAR-05 11:55	0.0669	ND			1	0.5
Bromodichloromethane	04-MAR-05 11:55	0.138	ND			1	0.5
cis-1,3-Dichloropropene	04-MAR-05 11:55	0.0979	ND			1	0.5
4-Methyl-2-Pentanone	04-MAR-05 11:55	0.0747	ND			1	0.5
Toluene	04-MAR-05 11:55	0.120	15.			1	0.5
trans-1,3-Dichloropropene	04-MAR-05 11:55	0.0788	ND			1	0.5
1,1,2-Trichloroethane	04-MAR-05 11:55	0.174	ND			1	0.5
Tetrachloroethene	04-MAR-05 11:55	0.117	0.53			1	0.5
2-Hexanone	04-MAR-05 11:55	0.0887	ND			1	0.5
Dibromochloromethane	04-MAR-05 11:55	0.125	ND			1	0.5
1,2-Dibromoethane	04-MAR-05 11:55	0.117	ND			1	0.5
Chlorobenzene	04-MAR-05 11:55	0.118	ND			1	0.5
Ethylbenzene	04-MAR-05 11:55	0.0872	8.2			1	0.5
m,p-Xylene	04-MAR-05 11:55	0.215	35.			1	1.0
o-Xylene	04-MAR-05 11:55	0.103	18.			1	0.5
Styrene	04-MAR-05 11:55	0.0625	0.28		J	1	0.5
Bromoform	04-MAR-05 11:55	0.118	ND			1	0.5
1,1,2,2-Tetrachloroethane	04-MAR-05 11:55	0.140	ND			1	0.5

960 West LeVoy Drive / Salt Lake City, Utah 84123-2547  
Phone (801) 266-7700 Web Page: www.datachem.com  
FAX (801) 268-9992 E-mail: lab@datachem.com



FORM A (TYPE I)  
SINGLE METHOD ANALYSES

Form RLIMS63A-V1.4  
03050512360228  
Page 6

SAMPLE ANALYSIS DATA SHEET



Date Printed : 05-MAR-05 12:36  
Client Name : Montana Tech

DCL Sample Name : 05I06988  
DCL Report Group : 05I-0676-06

Analytical Results

Analyte	Date Analyzed	MDL	Result	Comment	Qual.	Dilution	PQL
Benzyl Chloride	04-MAR-05 11:55	0.0856	ND			1	0.5
4-Ethyl toluene	04-MAR-05 11:55	0.0888	2.7			1	0.5
1,3,5-Trimethylbenzene	04-MAR-05 11:55	0.0592	3.4			1	0.5
1,2,4-Trimethylbenzene	04-MAR-05 11:55	0.0756	12.			1	0.5
1,3-Dichlorobenzene	04-MAR-05 11:55	0.133	ND			1	0.5
1,4-Dichlorobenzene	04-MAR-05 11:55	0.133	0.22		J	1	0.5
1,2-Dichlorobenzene	04-MAR-05 11:55	0.107	ND			1	0.5
1,2,4-Trichlorobenzene	04-MAR-05 11:55	0.149	ND			1	0.5
Hexachlorobutadiene	04-MAR-05 11:55	0.232	ND			1	0.5
Methyl t-Butyl Ether	04-MAR-05 11:55	0.111	ND			1	0.5
Total Petroleum Hydrocarbons	04-MAR-05 11:55		92.		J	1	

Tentatively Identified Compound Results

Analyte(Retention Time)	Date Analyzed	Result	Comment	Qual.	Dilution
Propene(4.49)	04-MAR-05 11:55	1.1			1
Acetaldehyde(4.84)	04-MAR-05 11:55	3.5		J	1
Ethanol(5.64)	04-MAR-05 11:55	8.4			1
Isopropyl Alcohol(6.28)	04-MAR-05 11:55	5.8			1
Pentane(6.40)	04-MAR-05 11:55	2.1		J	1
Ethyl Acetate(8.33)	04-MAR-05 11:55	1.1			1
Hexane(8.52)	04-MAR-05 11:55	0.81			1
Heptane(10.96)	04-MAR-05 11:55	1.1			1
BENZENE, PROPYL-(16.35)	04-MAR-05 11:55	2.8		J	1
Benzene, 1-ethyl-2-methyl-(16.84)	04-MAR-05 11:55	3.3		J	1
Benzene, 1,2,3-trimethyl-(17.66)	04-MAR-05 11:55	3.0		J	1

960 West LeVoy Drive / Salt Lake City, Utah 84123-2547  
Phone (801) 266-7700 Web Page: www.datachem.com  
FAX (801) 268-9992 E-mail: lab@datachem.com



FORM A (TYPE I)  
SINGLE METHOD ANALYSES

Form RLIMS63A-V1.4  
03050512360228  
Page 7

SAMPLE ANALYSIS DATA SHEET



Date Printed : 05-MAR-05 12:36

Client Sample Name: 220KA|108836

Client Name : Montana Tech  
Client Ref Number : Not Provided  
Sampling Site : Not Provided  
Release Number : Not Provided

DCL Sample Name : 05I06989  
DCL Report Group : 05I-0676-06

Date Received : 25-FEB-05 00:00

Matrix : AIR  
Date Sampled : Not Provided  
Reporting Units : PPB V/V  
Report Basis :  As Received  Dried

DCL Preparation Group: Not Applicable  
Date Prepared : Not Applicable  
Preparation Method : Not Applicable  
Aliquot Weight/Volume: 200 mL  
Net Weight/Volume : Not Required

DCL Analysis Group: G0523028  
Analysis Method : TO-15  
Instrument Type : GC/MS VO  
Instrument ID : 5972-0  
Column Type : DB-1

Primary  
 Confirmation

Analytical Results

Analyte	Date Analyzed	MDL	Result	Comment	Qual.	Dilution	PQL
Dichlorodifluoromethane	04-MAR-05 12:34	0.150	0.55			1	0.5
Chloromethane	04-MAR-05 12:34	0.187	0.71			1	0.5
Freon 114	04-MAR-05 12:34	0.155	ND			1	0.5
Vinyl Chloride	04-MAR-05 12:34	0.180	ND			1	0.5
Bromomethane	04-MAR-05 12:34	0.176	ND			1	0.5
Chloroethane	04-MAR-05 12:34	0.249	ND			1	0.5
Freon 11	04-MAR-05 12:34	0.132	0.37		J	1	0.5
cis-1,2-Dichloroethene	04-MAR-05 12:34	0.0938	ND			1	0.5
Carbon Disulfide	04-MAR-05 12:34	0.130	ND			1	0.5
Freon 113	04-MAR-05 12:34	0.124	ND			1	0.5
Acetone	04-MAR-05 12:34	0.179	19.			1	0.5
Methylene Chloride	04-MAR-05 12:34	0.117	0.42		J	1	0.5
trans-1,2-Dichloroethene	04-MAR-05 12:34	0.100	ND			1	0.5
1,1-Dichloroethane	04-MAR-05 12:34	0.143	ND			1	0.5
Vinyl Acetate	04-MAR-05 12:34	0.0642	ND			1	0.5
1,1-Dichloroethene	04-MAR-05 12:34	0.105	ND			1	0.5
2-Butanone	04-MAR-05 12:34	0.237	2.9			1	0.5
Chloroform	04-MAR-05 12:34	0.127	0.21		J	1	0.5
1,1,1-Trichloroethane	04-MAR-05 12:34	0.122	ND			1	0.5
Carbon Tetrachloride	04-MAR-05 12:34	0.161	ND			1	0.5
Benzene	04-MAR-05 12:34	0.0939	0.69			1	0.5
1,2-Dichloroethane	04-MAR-05 12:34	0.101	ND			1	0.5
Trichloroethene	04-MAR-05 12:34	0.109	0.21		J	1	0.5
1,2-Dichloropropane	04-MAR-05 12:34	0.0669	ND			1	0.5
Bromodichloromethane	04-MAR-05 12:34	0.138	ND			1	0.5
cis-1,3-Dichloropropene	04-MAR-05 12:34	0.0979	ND			1	0.5
4-Methyl-2-Pentanone	04-MAR-05 12:34	0.0747	ND			1	0.5
Toluene	04-MAR-05 13:14	0.120	22.			2	0.5
trans-1,3-Dichloropropene	04-MAR-05 12:34	0.0788	ND			1	0.5
1,1,2-Trichloroethane	04-MAR-05 12:34	0.174	ND			1	0.5
Tetrachloroethene	04-MAR-05 12:34	0.117	ND			1	0.5
2-Hexanone	04-MAR-05 12:34	0.0887	2.0			1	0.5
Dibromochloromethane	04-MAR-05 12:34	0.125	ND			1	0.5
1,2-Dibromoethane	04-MAR-05 12:34	0.117	ND			1	0.5
Chlorobenzene	04-MAR-05 12:34	0.118	ND			1	0.5
Ethylbenzene	04-MAR-05 12:34	0.0872	14.			1	0.5
m,p-Xylene	04-MAR-05 13:14	0.215	67.			2	1.0
o-Xylene	04-MAR-05 13:14	0.103	34.			2	0.5
Styrene	04-MAR-05 12:34	0.0625	0.49		J	1	0.5
Bromoform	04-MAR-05 12:34	0.118	ND			1	0.5
1,1,2,2-Tetrachloroethane	04-MAR-05 12:34	0.140	ND			1	0.5

960 West LeVoy Drive / Salt Lake City, Utah 84123-2547  
Phone (801) 266-7700 Web Page: www.Gatachem.com  
FAX (801) 268-9992 E-mail: lab@datachem.com



FORM A (TYPE I)  
SINGLE METHOD ANALYSES

Form RLIMS63A-V1.4  
03070512592414  
Page 8

SAMPLE ANALYSIS DATA SHEET



Date Printed : 07-MAR-05 12:59  
Client Name : Montana Tech

DCL Sample Name : 05I06989  
DCL Report Group : 05I-0676-06

Analytical Results

Analyte	Date Analyzed	MDL	Result	Comment	Qual.	Dilution	PQL
Benzyl Chloride	04-MAR-05 12:34	0.0856	ND			1	0.5
4-Ethyl toluene	04-MAR-05 12:34	0.0888	0.28		J	1	0.5
1,3,5-Trimethylbenzene	04-MAR-05 12:34	0.0592	15.			1	0.5
1,2,4-Trimethylbenzene	04-MAR-05 13:14	0.0756	64.		E	2	0.5
1,3-Dichlorobenzene	04-MAR-05 12:34	0.133	ND			1	0.5
1,4-Dichlorobenzene	04-MAR-05 12:34	0.133	0.21		J	1	0.5
1,2-Dichlorobenzene	04-MAR-05 12:34	0.107	ND			1	0.5
1,2,4-Trichlorobenzene	04-MAR-05 12:34	0.149	ND			1	0.5
Hexachlorobutadiene	04-MAR-05 12:34	0.232	ND			1	0.5
Methyl t-Butyl Ether	04-MAR-05 12:34	0.111	ND			1	0.5
Total Petroleum Hydrocarbons	04-MAR-05 12:34		220		J	1	

Tentatively Identified Compound Results

Analyte(Retention Time)	Date Analyzed	Result	Comment	Qual.	Dilution
Propene(4.50)	04-MAR-05 12:34	1.0			1
Acetaldehyde(4.88)	04-MAR-05 12:34	2.2		J	1
Ethanol(5.65)	04-MAR-05 12:34	21.			1
Isopropyl Alcohol(6.20)	04-MAR-05 12:34	160		E	1
Hexane(8.52)	04-MAR-05 12:34	0.47			1
Ethyl Acetate(8.61)	04-MAR-05 12:34	0.42			1
Heptane(10.96)	04-MAR-05 12:34	0.65			1
Hexane, 2,2,5-trimethyl-(12.96)	04-MAR-05 12:34	3.1		J	1
Acetic acid, butyl ester(13.23)	04-MAR-05 12:34	2.2		J	1
2-Hexanone, 5-methyl-(14.83)	04-MAR-05 12:34	2.6		J	1
Benzene, (1-methylethyl)-(15.78)	04-MAR-05 12:34	2.8		J	1
Benzene, 1,3,5-trimethyl-(16.61)	04-MAR-05 12:34	33.		J	1
Benzene, 1-ethyl-2-methyl-(16.84)	04-MAR-05 12:34	17.		J	1
Indene(17.92)	04-MAR-05 12:34	7.1		J	1
Benzene, 1-methyl-3-propyl-(18.11)	04-MAR-05 12:34	20.		J	1
Benzene, 4-ethyl-1,2-dimethyl-(18.20)	04-MAR-05 12:34	21.		J	1
Benzene, 1-methyl-4-propyl-(18.42)	04-MAR-05 12:34	5.5		J	1
Benzene, 2-ethyl-1,4-dimethyl-(18.56)	04-MAR-05 12:34	14.		J	1
Benzene, 2-ethyl-1,3-dimethyl-(18.71)	04-MAR-05 12:34	14.		J	1
Benzene, 1-ethyl-2,3-dimethyl-(19.10)	04-MAR-05 12:34	3.3		J	1
Benzene, 1,2,4,5-tetramethyl-(19.28)	04-MAR-05 12:34	9.4		J	1
Benzene, 1,2,3,5-tetramethyl-(19.35)	04-MAR-05 12:34	12.		J	1
Indene, 2,3-dihydro-4-methyl-(19.69)	04-MAR-05 12:34	3.8		J	1
Benzene, (1,2,2-trimethylpropyl)(19.78)	04-MAR-05 12:34	2.3		J	1
Benzene, 2-ethenyl-1,4-dimethyl(19.89)	04-MAR-05 12:34	10.		J	1
Benzene, 1,3-diechyl-5-methyl-(20.05)	04-MAR-05 12:34	2.1		J	1
Naphthalene(20.46)	04-MAR-05 12:34	16.		J	1
Benzene, pentamethyl-(20.55)	04-MAR-05 12:34	2.2		J	1

960 West LeVoy Drive / Salt Lake City, Utah 84123-2547  
Phone (801) 266-7700 Web Page: www.datachem.com  
FAX (801) 268-9992 E-mail: lab@datachem.com



FORM A (TYPE I)  
SINGLE METHOD ANALYSES

Form RLIMS63A-V1.4  
03050512360228  
Page 9

SAMPLE ANALYSIS DATA SHEET



S051W029

Date Printed : 05-MAR-05 12:36  
Client Name : Montana Tech  
Client Ref Number : Not Provided  
Sampling Site : Not Provided  
Release Number : Not Provided  
Date Received : 25-FEB-05 00:00

Client Sample Name: 220R|108964  
DCL Sample Name : 05I06990  
DCL Report Group : 05I-0676-06  
Matrix : AIR  
Date Sampled : Not Provided  
Reporting Units : PPB V/V  
Report Basis :  As Received  Dried

DCL Preparation Group: Not Applicable  
Date Prepared : Not Applicable  
Preparation Method : Not Applicable  
Aliquot Weight/Volume: 200 mL  
Net Weight/Volume : Not Required

DCL Analysis Group: G0523028  
Analysis Method : TO-15  
Instrument Type : GC/MS VO  
Instrument ID : 5972-0  
Column Type : DB-1  
 Primary  
 Confirmation

Analytical Results

Analyte	Date Analyzed	MDL	Result	Comment	Qual.	Dilution	PQL
Dichlorodifluoromethane	04-MAR-05 13:51	0.150	ND			1	0.5
Chloromethane	04-MAR-05 13:51	0.187	0.58			1	0.5
Freon 114	04-MAR-05 13:51	0.155	ND			1	0.5
Vinyl Chloride	04-MAR-05 13:51	0.180	ND			1	0.5
Bromomethane	04-MAR-05 13:51	0.176	ND			1	0.5
Chloroethane	04-MAR-05 13:51	0.249	ND			1	0.5
Freon 11	04-MAR-05 13:51	0.132	0.20		J	1	0.5
cis-1,2-Dichloroethene	04-MAR-05 13:51	0.0938	ND			1	0.5
Carbon Disulfide	04-MAR-05 13:51	0.130	0.29		J	1	0.5
Freon 113	04-MAR-05 13:51	0.124	ND			1	0.5
Acetone	04-MAR-05 13:51	0.179	11.			1	0.5
Methylene Chloride	04-MAR-05 13:51	0.117	0.32		J	1	0.5
trans-1,2-Dichloroethene	04-MAR-05 13:51	0.100	ND			1	0.5
1,1-Dichloroethane	04-MAR-05 13:51	0.143	ND			1	0.5
Vinyl Acetate	04-MAR-05 13:51	0.0642	ND			1	0.5
1,1-Dichloroethene	04-MAR-05 13:51	0.105	ND			1	0.5
2-Butanone	04-MAR-05 13:51	0.237	2.1			1	0.5
Chloroform	04-MAR-05 13:51	0.127	0.16		J	1	0.5
1,1,1-Trichloroethane	04-MAR-05 13:51	0.122	ND			1	0.5
Carbon Tetrachloride	04-MAR-05 13:51	0.161	ND			1	0.5
Benzene	04-MAR-05 13:51	0.0939	1.0			1	0.5
1,2-Dichloroethane	04-MAR-05 13:51	0.101	ND			1	0.5
Trichloroethene	04-MAR-05 13:51	0.109	0.18		J	1	0.5
1,2-Dichloropropane	04-MAR-05 13:51	0.0669	ND			1	0.5
Bromodichloromethane	04-MAR-05 13:51	0.138	ND			1	0.5
cis-1,3-Dichloropropene	04-MAR-05 13:51	0.0979	ND			1	0.5
4-Methyl-2-Pentanone	04-MAR-05 13:51	0.0747	ND			1	0.5
Toluene	04-MAR-05 13:51	0.120	1.9			1	0.5
trans-1,3-Dichloropropene	04-MAR-05 13:51	0.0788	ND			1	0.5
1,1,2-Trichloroethane	04-MAR-05 13:51	0.174	ND			1	0.5
Tetrachloroethene	04-MAR-05 13:51	0.117	ND			1	0.5
2-Hexanone	04-MAR-05 13:51	0.0887	ND			1	0.5
Dibromochloromethane	04-MAR-05 13:51	0.125	ND			1	0.5
1,2-Dibromoethane	04-MAR-05 13:51	0.117	ND			1	0.5
Chlorobenzene	04-MAR-05 13:51	0.118	ND			1	0.5
Ethylbenzene	04-MAR-05 13:51	0.0872	0.50			1	0.5
m,p-Xylene	04-MAR-05 13:51	0.215	2.3			1	1.0
o-Xylene	04-MAR-05 13:51	0.103	0.72			1	0.5
Styrene	04-MAR-05 13:51	0.0625	0.22		J	1	0.5
Bromoform	04-MAR-05 13:51	0.118	ND			1	0.5
1,1,2,2-Tetrachloroethane	04-MAR-05 13:51	0.140	ND			1	0.5

960 West LeVoy Drive / Salt Lake City, Utah 84123-2547  
Phone (801) 266-7700 Web Page: www.datachem.com  
FAX (801) 268-9992 E-mail: lab@datachem.com



FORM A (TYPE I)  
SINGLE METHOD ANALYSES

Form RLIMS63A-V1.4  
03050512360228  
Page 10

SAMPLE ANALYSIS DATA SHEET



S051W020

Date Printed : 05-MAR-05 12:36  
Client Name : Montana Tech

DCL Sample Name : 05I06990  
DCL Report Group : 05I-0676-06

Analytical Results

Analyte	Date Analyzed	MDL	Result	Comment	Qual.	Dilution	PQL
Benzyl Chloride	04-MAR-05 13:51	0.0856	ND			1	0.5
4-Ethyl toluene	04-MAR-05 13:51	0.0888	0.20		J	1	0.5
1,3,5-Trimethylbenzene	04-MAR-05 13:51	0.0592	0.19		J	1	0.5
1,2,4-Trimethylbenzene	04-MAR-05 13:51	0.0756	0.43		J	1	0.5
1,3-Dichlorobenzene	04-MAR-05 13:51	0.133	ND			1	0.5
1,4-Dichlorobenzene	04-MAR-05 13:51	0.133	0.16		J	1	0.5
1,2-Dichlorobenzene	04-MAR-05 13:51	0.107	ND			1	0.5
1,2,4-Trichlorobenzene	04-MAR-05 13:51	0.149	ND			1	0.5
Hexachlorobutadiene	04-MAR-05 13:51	0.232	ND			1	0.5
Methyl t-Butyl Ether	04-MAR-05 13:51	0.111	ND			1	0.5
Total Petroleum Hydrocarbons	04-MAR-05 13:51		17.		J	1	

Tentatively Identified Compound Results

Analyte(Retention Time)	Date Analyzed	Result	Comment	Qual.	Dilution
Propene(4.49)	04-MAR-05 13:51	11.			1
Acetaldehyde(4.83)	04-MAR-05 13:51	2.8		J	1
Butane(5.08)	04-MAR-05 13:51	4.0		J	1
Ethanol(5.68)	04-MAR-05 13:51	37.		E	1
Isopropyl Alcohol(6.30)	04-MAR-05 13:51	24.		E	1
Ethyl Acetate(8.33)	04-MAR-05 13:51	0.62			1
Hexane(8.51)	04-MAR-05 13:51	0.73			1
Heptane(10.96)	04-MAR-05 13:51	0.50			1

960 West LeVoy Drive / Salt Lake City, Utah 84123-2547  
Phone (801) 266-7700 Web Page: www.datachem.com  
FAX (801) 268-9992 E-mail: lab@datachem.com



FORM A (TYPE I)  
SINGLE METHOD ANALYSES

Form RLIMS63A-V1.4  
03050512360228  
Page 11

SAMPLE ANALYSIS DATA SHEET



Date Printed : 05-MAR-05 12:36  
Client Name : Montana Tech  
Client Ref Number : Not Provided  
Sampling Site : Not Provided  
Release Number : Not Provided  
Date Received : 25-FEB-05 00:00

Client Sample Name: 222KA|108966  
DCL Sample Name : 05I06991  
DCL Report Group : 05I-0676-06  
Matrix : AIR  
Date Sampled : Not Provided  
Reporting Units : PPB V/V  
Report Basis :  As Received  Dried

DCL Preparation Group: Not Applicable  
Date Prepared : Not Applicable  
Preparation Method : Not Applicable  
Aliquot Weight/Volume: 200 mL  
Net Weight/Volume : Not Required

DCL Analysis Group: G0523028  
Analysis Method : TO-15  
Instrument Type : GC/MS VO  
Instrument ID : 5972-0  
Column Type : DB-1  
 Primary  
 Confirmation

Analytical Results

Analyte	Date Analyzed	MDL	Result	Comment	Qual.	Dilution	PQL
Dichlorodifluoromethane	04-MAR-05 14:28	0.150	ND			1	0.5
Chloromethane	04-MAR-05 14:28	0.187	ND			1	0.5
Freon 114	04-MAR-05 14:28	0.155	ND			1	0.5
Vinyl Chloride	04-MAR-05 14:28	0.180	ND			1	0.5
Bromomethane	04-MAR-05 14:28	0.176	ND			1	0.5
Chloroethane	04-MAR-05 14:28	0.249	ND			1	0.5
Freon 11	04-MAR-05 14:28	0.132	ND			1	0.5
cis-1,2-Dichloroethene	04-MAR-05 14:28	0.0938	ND			1	0.5
Carbon Disulfide	04-MAR-05 14:28	0.130	ND			1	0.5
Freon 113	04-MAR-05 14:28	0.124	ND			1	0.5
Acetone	04-MAR-05 14:28	0.179	1.2			1	0.5
Methylene Chloride	04-MAR-05 14:28	0.117	ND			1	0.5
trans-1,2-Dichloroethene	04-MAR-05 14:28	0.100	ND			1	0.5
1,1-Dichloroethane	04-MAR-05 14:28	0.143	ND			1	0.5
Vinyl Acetate	04-MAR-05 14:28	0.0642	ND			1	0.5
1,1-Dichloroethene	04-MAR-05 14:28	0.105	ND			1	0.5
2-Butanone	04-MAR-05 14:28	0.237	ND			1	0.5
Chloroform	04-MAR-05 14:28	0.127	ND			1	0.5
1,1,1-Trichloroethane	04-MAR-05 14:28	0.122	ND			1	0.5
Carbon Tetrachloride	04-MAR-05 14:28	0.161	ND			1	0.5
Benzene	04-MAR-05 14:28	0.0939	ND			1	0.5
1,2-Dichloroethane	04-MAR-05 14:28	0.101	ND			1	0.5
Trichloroethene	04-MAR-05 14:28	0.109	ND			1	0.5
1,2-Dichloropropane	04-MAR-05 14:28	0.0669	ND			1	0.5
Bromodichloromethane	04-MAR-05 14:28	0.138	ND			1	0.5
cis-1,3-Dichloropropene	04-MAR-05 14:28	0.0979	ND			1	0.5
4-Methyl-2-Pentanone	04-MAR-05 14:28	0.0747	ND			1	0.5
Toluene	04-MAR-05 14:28	0.120	ND			1	0.5
trans-1,3-Dichloropropene	04-MAR-05 14:28	0.0788	ND			1	0.5
1,1,2-Trichloroethane	04-MAR-05 14:28	0.174	ND			1	0.5
Tetrachloroethene	04-MAR-05 14:28	0.117	ND			1	0.5
2-Hexanone	04-MAR-05 14:28	0.0887	ND			1	0.5
Dibromochloromethane	04-MAR-05 14:28	0.125	ND			1	0.5
1,2-Dibromoethane	04-MAR-05 14:28	0.117	ND			1	0.5
Chlorobenzene	04-MAR-05 14:28	0.118	ND			1	0.5
Ethylbenzene	04-MAR-05 14:28	0.0872	ND			1	0.5
m,p-Xylene	04-MAR-05 14:28	0.215	ND			1	1.0
o-Xylene	04-MAR-05 14:28	0.103	ND			1	0.5
Styrene	04-MAR-05 14:28	0.0625	ND			1	0.5
Bromoform	04-MAR-05 14:28	0.118	ND			1	0.5
1,1,2,2-Tetrachloroethane	04-MAR-05 14:28	0.140	ND			1	0.5

960 West LeVoy Drive / Salt Lake City, Utah 84123-2547  
Phone (801) 266-7700 Web Page: www.datachem.com  
FAX (801) 268-9992 E-mail: lab@datachem.com





FORM A (TYPE I)  
SINGLE METHOD ANALYSES

Form RLIMS63A-V1.4  
03050512360228  
Page 12

SAMPLE ANALYSIS DATA SHEET



Date Printed : 05-MAR-05 12:36  
Client Name : Montana Tech

DCL Sample Name : 05I06991  
DCL Report Group : 05I-0676-06

Analytical Results

Analyte	Date Analyzed	MDL	Result	Comment	Qual.	Dilution	POL
Benzyl Chloride	04-MAR-05 14:28	0.0856	ND			1	0.5
4-Ethyl toluene	04-MAR-05 14:28	0.0888	ND			1	0.5
1,3,5-Trimethylbenzene	04-MAR-05 14:28	0.0592	ND			1	0.5
1,2,4-Trimethylbenzene	04-MAR-05 14:28	0.0756	ND			1	0.5
1,3-Dichlorobenzene	04-MAR-05 14:28	0.133	ND			1	0.5
1,4-Dichlorobenzene	04-MAR-05 14:28	0.133	ND			1	0.5
1,2-Dichlorobenzene	04-MAR-05 14:28	0.107	ND			1	0.5
1,2,4-Trichlorobenzene	04-MAR-05 14:28	0.149	ND			1	0.5
Hexachlorobutadiene	04-MAR-05 14:28	0.232	ND			1	0.5
Methyl t-Butyl Ether	04-MAR-05 14:28	0.111	ND			1	0.5
Total Petroleum Hydrocarbons	04-MAR-05 14:28		.43		J	1	

Tentatively Identified Compound Results

Analyte (Retention Time)	Date Analyzed	Result	Comment	Qual.	Dilution
Isopropyl Alcohol (6.29)	04-MAR-05 14:28	6.1			1

960 West LeVoy Drive / Salt Lake City, Utah 84123-2547  
Phone (801) 266-7700 Web Page: www.datachem.com  
FAX (801) 268-9992 E-mail: lab@datachem.com



FORM A (TYPE I)  
SINGLE METHOD ANALYSES

Form RLIMS63A-V1.4  
03050512360228  
Page 13

SAMPLE ANALYSIS DATA SHEET



Date Printed : 05-MAR-05 12:36  
Client Name : Montana Tech  
Client Ref Number : Not Provided  
Sampling Site : Not Provided  
Release Number : Not Provided  
Date Received : 25-FEB-05 00:00

Client Sample Name: 222AI|108769  
DCL Sample Name : 05I06992  
DCL Report Group : 05I-0676-06  
Matrix : AIR  
Date Sampled : Not Provided  
Reporting Units : PPB V/V  
Report Basis :  As Received  Dried

DCL Preparation Group: Not Applicable  
Date Prepared : Not Applicable  
Preparation Method : Not Applicable  
Aliquot Weight/Volume: 200 mL  
Net Weight/Volume : Not Required

DCL Analysis Group: G0523028  
Analysis Method : TO-15  
Instrument Type : GC/MS V0  
Instrument ID : 5972-0  
Column Type : DB-1  
 Primary  
 Confirmation

Analytical Results

Analyte	Date Analyzed	MDL	Result	Comment	Qual.	Dilution	PQL
Dichlorodifluoromethane	04-MAR-05 15:05	0.150	ND			1	0.5
Chloromethane	04-MAR-05 15:05	0.187	ND			1	0.5
Freon 114	04-MAR-05 15:05	0.155	ND			1	0.5
Vinyl Chloride	04-MAR-05 15:05	0.180	ND			1	0.5
Bromomethane	04-MAR-05 15:05	0.176	ND			1	0.5
Chloroethane	04-MAR-05 15:05	0.249	ND			1	0.5
Freon 11	04-MAR-05 15:05	0.132	ND			1	0.5
cis-1,2-Dichloroethene	04-MAR-05 15:05	0.0938	ND			1	0.5
Carbon Disulfide	04-MAR-05 15:05	0.130	ND			1	0.5
Freon 113	04-MAR-05 15:05	0.124	ND			1	0.5
Acetone	04-MAR-05 15:05	0.179	1.3			1	0.5
Methylene Chloride	04-MAR-05 15:05	0.117	ND			1	0.5
trans-1,2-Dichloroethene	04-MAR-05 15:05	0.100	ND			1	0.5
1,1-Dichloroethane	04-MAR-05 15:05	0.143	ND			1	0.5
Vinyl Acetate	04-MAR-05 15:05	0.0642	ND			1	0.5
1,1-Dichloroethene	04-MAR-05 15:05	0.105	ND			1	0.5
2-Butanone	04-MAR-05 15:05	0.237	ND			1	0.5
Chloroform	04-MAR-05 15:05	0.127	ND			1	0.5
1,1,1-Trichloroethane	04-MAR-05 15:05	0.122	ND			1	0.5
Carbon Tetrachloride	04-MAR-05 15:05	0.161	ND			1	0.5
Benzene	04-MAR-05 15:05	0.0939	ND			1	0.5
1,2-Dichloroethane	04-MAR-05 15:05	0.101	ND			1	0.5
Trichloroethene	04-MAR-05 15:05	0.109	ND			1	0.5
1,2-Dichloropropane	04-MAR-05 15:05	0.0669	ND			1	0.5
Bromodichloromethane	04-MAR-05 15:05	0.138	ND			1	0.5
cis-1,3-Dichloropropene	04-MAR-05 15:05	0.0979	ND			1	0.5
4-Methyl-2-Pentanone	04-MAR-05 15:05	0.0747	ND			1	0.5
Toluene	04-MAR-05 15:05	0.120	ND			1	0.5
trans-1,3-Dichloropropene	04-MAR-05 15:05	0.0788	ND			1	0.5
1,1,2-Trichloroethane	04-MAR-05 15:05	0.174	ND			1	0.5
Tetrachloroethene	04-MAR-05 15:05	0.117	ND			1	0.5
2-Hexanone	04-MAR-05 15:05	0.0887	ND			1	0.5
Dibromochloromethane	04-MAR-05 15:05	0.125	ND			1	0.5
1,2-Dibromoethane	04-MAR-05 15:05	0.117	ND			1	0.5
Chlorobenzene	04-MAR-05 15:05	0.118	ND			1	0.5
Ethylbenzene	04-MAR-05 15:05	0.0872	ND			1	0.5
m,p-Xylene	04-MAR-05 15:05	0.215	ND			1	1.0
o-Xylene	04-MAR-05 15:05	0.103	ND			1	0.5
Styrene	04-MAR-05 15:05	0.0625	ND			1	0.5
Bromoform	04-MAR-05 15:05	0.118	ND			1	0.5
1,1,2,2-Tetrachloroethane	04-MAR-05 15:05	0.140	ND			1	0.5

960 West LeVoy Drive / Salt Lake City, Utah 84123-2547  
Phone (801) 266-7700 Web Page: www.datachem.com  
FAX (801) 268-9992 E-mail: lab@datachem.com



FORM A (TYPE I)  
SINGLE METHOD ANALYSES

Form RLIMS63A-V1.4  
03050512360228  
Page 14

SAMPLE ANALYSIS DATA SHEET



Date Printed : 05-MAR-05 12:36  
Client Name : Montana Tech

DCL Sample Name : 05I06992  
DCL Report Group : 05I-0676-06

Analytical Results

Analyte	Date Analyzed	MDL	Result	Comment	Qual.	Dilution	PCL
Benzyl Chloride	04-MAR-05 15:05	0.0856	ND			1	0.5
4-Ethyl toluene	04-MAR-05 15:05	0.0888	ND			1	0.5
1,3,5-Trimethylbenzene	04-MAR-05 15:05	0.0592	ND			1	0.5
1,2,4-Trimethylbenzene	04-MAR-05 15:05	0.0756	ND			1	0.5
1,3-Dichlorobenzene	04-MAR-05 15:05	0.133	ND			1	0.5
1,4-Dichlorobenzene	04-MAR-05 15:05	0.133	ND			1	0.5
1,2-Dichlorobenzene	04-MAR-05 15:05	0.107	ND			1	0.5
1,2,4-Trichlorobenzene	04-MAR-05 15:05	0.149	ND			1	0.5
Hexachlorobutadiene	04-MAR-05 15:05	0.232	ND			1	0.5
Methyl t-Butyl Ether	04-MAR-05 15:05	0.111	ND			1	0.5
Total Petroleum Hydrocarbons	04-MAR-05 15:05		ND			1	

960 West LeVoy Drive / Salt Lake City, Utah 84123-2547  
Phone (801) 266-7700 Web Page: www.datachem.com  
FAX (801) 268-9992 E-mail: lab@datachem.com



FORM J (TYPE I)  
SINGLE METHOD ANALYSES

QUALITY CONTROL DATA SHEET  
LABORATORY CONTROL SAMPLE (LCS)  
LABORATORY CONTROL DUPL (LCD)

Form RLIMS63J-V1.4  
03050512360228  
Page 15



S052101V

Client Name : Montana Tech  
Release Number : Not Provided

DCL Sample Name : QC-229040-1  
Date Printed : 05-MAR-05 12:36

Matrix : AIR  
Reporting Units : ppb v/v

DCL Analysis Group: G0523028  
Analysis Method : T015  
Instrument Type : GC/MS VO  
Instrument ID : 5972-0  
Column Type : DB-1

DCL Preparation Group: Not Applicable  
Date Prepared : Not Applicable  
Preparation Method : Not Applicable

Primary  
 Confirmation

QC Limit Type : Method

Analytical Results

Analyte	Date Analyzed	Target	Result	Percent Recovery	QC Limits	QC Flag
Vinyl Chloride	04-MAR-05 09:17	10.0	8.52	85.2	70.0/130.	
cis-1,2-Dichloroethene	04-MAR-05 09:17	10.0	8.68	86.8	70.0/130.	
Methylene Chloride	04-MAR-05 09:17	10.0	8.91	89.1	70.0/130.	
trans-1,2-Dichloroethene	04-MAR-05 09:17	10.0	8.71	87.1	70.0/130.	
1,1-Dichloroethane	04-MAR-05 09:17	10.0	8.87	88.7	70.0/130.	
1,1-Dichloroethane	04-MAR-05 09:17	10.0	8.95	89.5	70.0/130.	
Chloroform	04-MAR-05 09:17	10.0	8.66	86.6	70.0/130.	
1,1,1-Trichloroethane	04-MAR-05 09:17	10.0	8.49	84.9	70.0/130.	
Carbon Tetrachloride	04-MAR-05 09:17	10.0	8.42	84.2	70.0/130.	
Benzene	04-MAR-05 09:17	10.0	8.58	85.8	70.0/130.	
1,2-Dichloroethane	04-MAR-05 09:17	10.0	8.90	89.0	70.0/130.	
Trichloroethene	04-MAR-05 09:17	10.0	8.38	83.8	70.0/130.	
1,2-Dichloropropane	04-MAR-05 09:17	10.0	8.65	86.5	70.0/130.	
Toluene	04-MAR-05 09:17	10.0	8.52	85.2	70.0/130.	
trans-1,3-Dichloropropene	04-MAR-05 09:17	10.0	8.36	83.6	70.0/130.	
1,1,2-Trichloroethane	04-MAR-05 09:17	10.0	8.45	84.5	70.0/130.	
Tetrachloroethene	04-MAR-05 09:17	10.0	8.52	85.2	70.0/135.	
1,2-Dibromoethane	04-MAR-05 09:17	10.0	8.37	83.7	70.0/130.	
Ethylbenzene	04-MAR-05 09:17	10.0	8.47	84.7	70.0/130.	
m,p-Xylene	04-MAR-05 09:17	20.0	16.6	82.8	70.0/130.	
o-Xylene	04-MAR-05 09:17	10.0	8.44	84.4	70.0/130.	
Styrene	04-MAR-05 09:17	10.0	8.35	83.5	70.0/130.	
1,1,2,2-Tetrachloroethane	04-MAR-05 09:17	10.0	8.36	83.6	70.0/130.	
Ethanol	04-MAR-05 09:17	10.0	7.90	79.0	70.0/130.	



S052101W

DCL Sample Name : QD-229040-1

Analytical Results

Analyte	Date Analyzed	Duplicate Result	Percent Recovery	Mean	Range	RPD	QC Limits	QC Flag
Vinyl Chloride	04-MAR-05 09:59	8.61	86.1	8.56	0.0930	1.1	0.00/25.0	
cis-1,2-Dichloroethene	04-MAR-05 09:59	8.99	89.9	8.83	0.305	3.5	0.00/25.0	
Methylene Chloride	04-MAR-05 09:59	8.92	89.2	8.91	0.0110	0.12	0.00/25.0	
trans-1,2-Dichloroethene	04-MAR-05 09:59	8.94	89.4	8.83	0.231	2.6	0.00/25.0	
1,1-Dichloroethane	04-MAR-05 09:59	9.17	91.7	9.02	0.298	3.3	0.00/25.0	
1,1-Dichloroethane	04-MAR-05 09:59	9.22	92.2	9.08	0.277	3.0	0.00/25.0	
Chloroform	04-MAR-05 09:59	8.91	89.1	8.78	0.254	2.9	0.00/25.0	
1,1,1-Trichloroethane	04-MAR-05 09:59	8.73	87.3	8.61	0.242	2.8	0.00/25.0	
Carbon Tetrachloride	04-MAR-05 09:59	8.66	86.6	8.54	0.236	2.8	0.00/25.0	
Benzene	04-MAR-05 09:59	8.87	88.7	8.73	0.291	3.3	0.00/25.0	
1,2-Dichloroethane	04-MAR-05 09:59	9.03	90.3	8.97	0.129	1.4	0.00/25.0	

960 West LeVoy Drive / Salt Lake City, Utah 84123-2547  
Phone (801) 266-7700 Web Page: www.datachem.com  
FAX (801) 268-9992 E-mail: lab@datachem.com



FORM J (TYPE I)  
SINGLE METHOD ANALYSES

QUALITY CONTROL DATA SHEET  
LABORATORY CONTROL SAMPLE (LCS)  
LABORATORY CONTROL DUPL (LCD)

Form RLIMS63J-V1.4  
03050512360228  
Page 16



Client Name : Montana Tech

DCL Sample Name : QD-229040-1  
Date Printed : 05-MAR-05 12:36

Analytical Results

Analyte	Date Analyzed	Duplicate Result	Percent Recovery	Mean	Range	RPD	QC Limits	QC Flag
Trichloroethene	04-MAR-05 09:59	8.62	86.2	8.50	0.245	2.9	0.00/25.0	
1,2-Dichloropropane	04-MAR-05 09:59	8.83	88.3	8.74	0.175	2.0	0.00/25.0	
Toluene	04-MAR-05 09:59	8.70	87.0	8.61	0.188	2.2	0.00/25.0	
trans-1,3-Dichloropropene	04-MAR-05 09:59	8.68	86.8	8.52	0.317	3.7	0.00/25.0	
1,1,2-Trichloroethane	04-MAR-05 09:59	8.65	86.5	8.55	0.197	2.3	0.00/25.0	
Tetrachloroethene	04-MAR-05 09:59	8.72	87.2	8.62	0.193	2.2	0.00/25.0	
1,2-Dibromoethane	04-MAR-05 09:59	8.54	85.4	8.45	0.169	2.0	0.00/25.0	
Ethylbenzene	04-MAR-05 09:59	8.81	88.1	8.64	0.338	3.9	0.00/25.0	
m,p-Xylene	04-MAR-05 09:59	17.3	86.5	16.9	0.738	4.4	0.00/25.0	
o-Xylene	04-MAR-05 09:59	8.74	87.4	8.59	0.305	3.6	0.00/25.0	
Styrene	04-MAR-05 09:59	8.69	86.9	8.52	0.335	3.9	0.00/25.0	
1,1,1,2-Tetrachloroethane	04-MAR-05 09:59	8.68	86.8	8.52	0.320	3.8	0.00/25.0	
Ethanol	04-MAR-05 09:59	8.47	84.7	8.18	0.565	6.9	0.00/25.0	

960 West LeVoy Drive / Salt Lake City, Utah 84123-2547  
Phone (801) 266-7700 Web Page: www.datachem.com  
FAX (801) 268-9992 E-mail: lab@datachem.com



FORM G (TYPE I)  
SINGLE METHOD ANALYSES

Form RLIMS63G-V1.4  
03050512360228  
Page 17

QUALITY CONTROL DATA SHEET  
SURROGATE SUMMARY



G0523028

Client Name : Montana Tech  
Release Number : Not Provided  
Matrix : AIR  
Reporting Units : ppb v/v

Date Printed : 05-MAR-05 12:36

DCL Analysis Group: G0523028  
Analysis Method : TO15

DCL Prep Group : Not Applicable  
Preparation Method: Not Applicable

QC Limit Type : Method

Surrogate Recoveries

Surr. ID	4-Bromofluorobenzene								
QC Limits	65.0/135.								
DCL Sample Number	Analyte Result	Spiked Amount	% Rec. Q	Analyte Result	Spiked Amount	% Rec. Q	Analyte Result	Spiked Amount	% Rec. Q
05I06987	19.2	20.0	96.0						
05I06988	19.5	20.0	97.7						
05I06989	19.5	20.0	97.3						
05I06990	18.4	20.0	92.0						
05I06991	19.6	20.0	97.9						
05I06992	19.3	20.0	96.4						
BL-229040-1	18.8	20.0	94.1						
QC-229040-1	19.4	20.0	97.1						
QD-229040-1	19.9	20.0	99.3						

960 West LeVoy Drive / Salt Lake City, Utah 84123-2547  
Phone (801) 266-7700 Web Page: www.datachem.com  
FAX (801) 268-9992 E-mail: lab@datachem.com



**DATA  
CHEM**  
LABORATORIES, INC.

### ANALYTICAL REQUEST FORM

1.  REGULAR Status 05FEB7006  
 RUSH Status Requested - ADDITIONAL CHARGE  
 RESULTS REQUIRED BY \_\_\_\_\_ DATE \_\_\_\_\_  
 CONTACT DATACHEM LABS PRIOR TO SENDING SAMPLES

2. Date 2-22-05 Purchase Order No. \_\_\_\_\_ 4. Quote No. \_\_\_\_\_  
 3. Company Name Montana Tech DCL Project Manager \_\_\_\_\_  
 Address 1300 West Park St 5. Sample Collection \_\_\_\_\_  
Butte MT 59701 Sampling Site \_\_\_\_\_  
 Person to Contact Terry Spear Industrial Process \_\_\_\_\_  
 Telephone (406) 496 4445 Date of Collection \_\_\_\_\_  
 Fax Telephone (406) 496 4650 Time Collected \_\_\_\_\_  
 E-mail Address tspear@montatech.edu Date of Shipment \_\_\_\_\_  
 Billing Address (if different from above) Chain of Custody No \_\_\_\_\_

6. REQUEST FOR ANALYSES

Laboratory Use Only	Client Sample Number	Matrix*	Sample Volume	ANALYSES REQUESTED - Use method number if known	Units**
<del>88</del>	<u>219 KA</u>	<u>4in can</u>		<u>EPA method TC 16 + TPH</u>	<u>108527</u>
<del>88</del>	<u>219 B</u>	<u>" "</u>		<u>" " " "</u>	<u>10875</u>
<del>88</del>	<u>220 KA</u>	<u>" "</u>		<u>" " " "</u>	<u>108826</u>
<del>76</del>	<u>220 R</u>	<u>" "</u>		<u>" " " "</u>	<u>108904</u>
<del>91</del>	<u>222 KA</u>	<u>" "</u>		<u>" " " "</u>	<u>108910</u>
<del>92</del>	<u>222 AI</u>	<u>" "</u>		<u>" " " "</u>	<u>108908</u>

\* Specify: Solid sorbent tube, e.g Charcoal; Filter type; Impinger solution; Bulk sample; Blood; Urine; Tissue; Soil; Water; Other  
 \*\* 1. ug/sample 2. mg/m<sup>3</sup> 3 ppm 4. % 5 \_\_\_\_\_ (other) Please indicate one or more units in the column entitled Units\*\*

Comments \_\_\_\_\_

Possible Contamination and/or Chemical Hazards \_\_\_\_\_

7. Chain of Custody (Optional)

Relinquished by _____	Date/Time _____
Received by <u>Rand Pott</u>	Date/Time <u>2/25</u>
Relinquished by <u>Rand Pott</u>	Date/Time <u>2/25</u>
Received by _____	Date/Time _____
Relinquished by _____	Date/Time _____
Received by _____	Date/Time _____

960 West LeVoy Drive / Salt Lake City, UT 84123  
 DATACHEM LABORATORIES, INC.

800-356-9135 or 801-266-7700 / FAX: 801-268-9992  
 www.datachem.com

## **Appendix F**



**Figure 1: Yellowstone National Park**

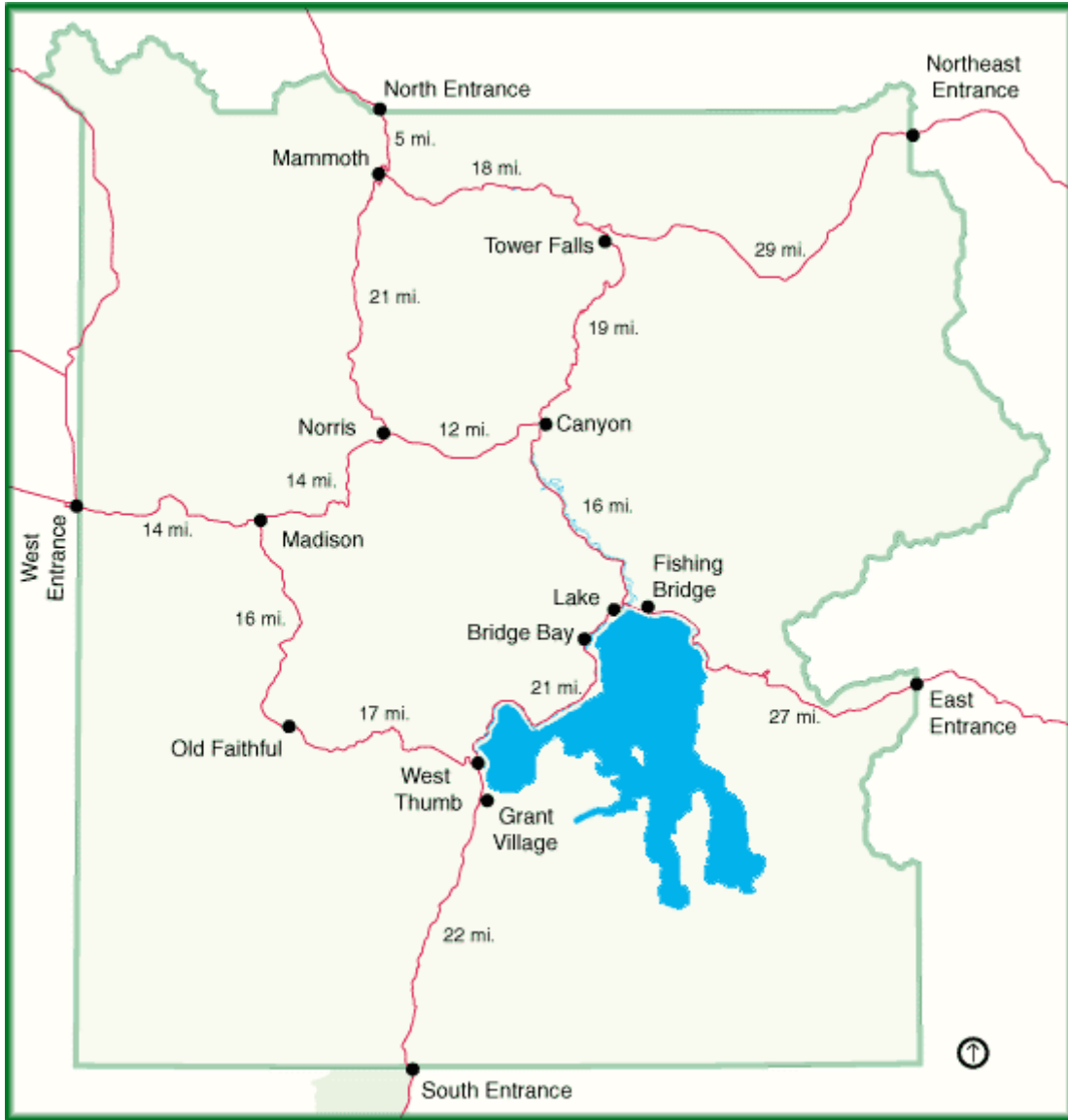

- #1 mini-can** -- Area sample in kiosk A at the West Entrance.
- 116 G**----- Area sample in kiosk A at the West Entrance.
- 116 SM** ----- Personal sample worn by a Park Ranger operating 2003 BAT Polaris Frontier Touring snowmobile. The Ranger started at the West Entrance and drove to the warming hut at Madison. The Ranger then drove to Old Faithful before his return trip to the West Entrance. On the return trip the Ranger stopped at the warming hut in Madison.
- 117 G**----- Area sample in kiosk A at the West Entrance.
- MC27** ----- Personal sample collected from a mechanic at the Mammoth maintenance shop.
- 219KA** ----- Area sample in kiosk A at the West Entrance.

- 219OB** -----Area sample collected in the West Entrance office.
- 220KA** -----Area sample in kiosk A at the West Entrance.
- 220R**-----Personal sample worn by a law enforcement ranger operating a 2004 BAT Arctic Cat T660 Touring snowmobile. The Law Enforcement Ranger started the work shift at Old Faithful and over the course of her 8 hour workday she throughout most of the area around Old Faithful.
- 220KA** -----Area sample in kiosk A at the West Entrance.
- 222AI** -----Area sample collected near the air intake to the kiosk ventilation system

**Figure 2. West Entrance Ventilation System**

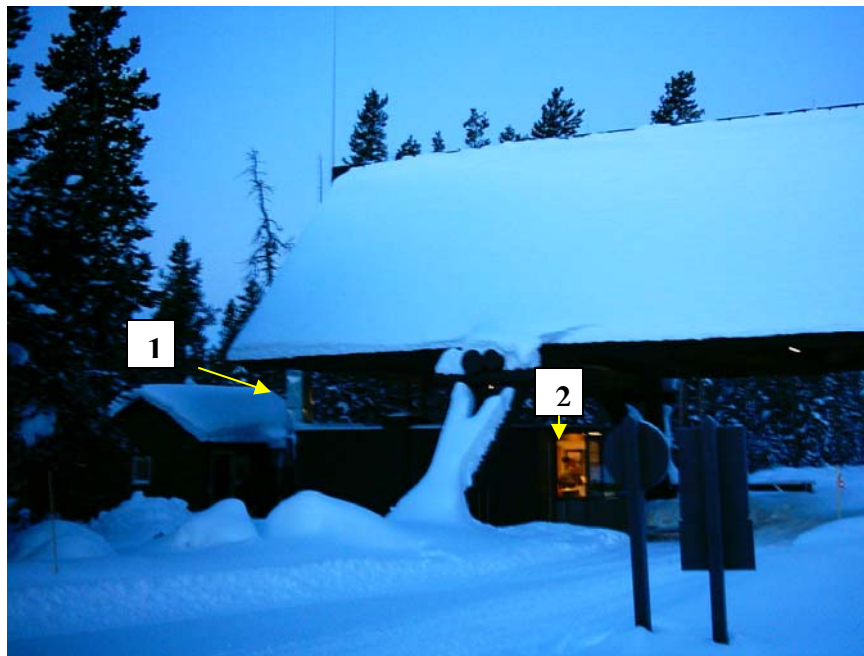

**1** – Ventilation intake is located 115 feet east of the ventilation section number 1 is pointing to. The control mini-can sample was taken 10 feet from the intake, approximately 105 feet from location number 1. The ventilation intake consists of a 24 inch diameter plastic pipe. The end of the intake is the shape of a horsehead and is covered with a wire mesh grid to preventing large objects from entering.

**2** – The area that is lit up underneath 2 is the West Entrance office. Mini-can sample 219OB was taken inside the office. This section is not connected to the ventilation system that supplies air to the kiosks.

**Figure 3. Kiosk A at the West Entrance**



**1** – Area samples were taken right behind where the arrows from 1 are pointing. The area samples were positioned so that when the window was opened the sampling media was within the breathing zone of the employee.

**2** – Duct providing air to the kiosk. The ventilation system maintains a positive pressure in the kiosks.